



**ROYAL CANADIAN AIR CADETS  
PROFICIENCY LEVEL FOUR  
INSTRUCTIONAL GUIDE**



**SECTION 1**

**EO M436.01 – EXPLAIN WINDS**

---

Total Time: 30 min

---

**PREPARATION**

---

**PRE-LESSON INSTRUCTIONS**

Resources needed for the delivery of this lesson are listed in the lesson specification located in A-CR-CCP-804/PG-001, *Proficiency Level Four Qualification Standard and Plan*, Chapter 4. Specific uses for said resources are identified throughout the instructional guide within the TP for which they are required.

Review the lesson content and become familiar with the material prior to delivering the lesson.

Prepare the slides or handouts located at Attachment A.

**PRE-LESSON ASSIGNMENT**

Nil.

**APPROACH**

An interactive lecture was chosen for this lesson to orient the cadets to winds and generate interest in the subject.

---

**INTRODUCTION**

---

**REVIEW**

Nil.

**OBJECTIVES**

By the end of this lesson the cadet shall have explained winds.

**IMPORTANCE**

It is important for the cadets to explain winds as this information is used by pilots to be aware of the direction and speed of wind during all parts of the flight. Being able to explain winds provides knowledge for potential instructional duties and is part of the fundamentals that cadets pursuing future aviation training will require.

---

**Teaching Point 1****Explain surface winds.**

Time: 15 min

Method: Interactive Lecture

---

**SURFACE WINDS**

Wind is a major factor in flight planning and flight characteristics. Pilots must constantly be aware of the direction and speed of wind during the flight, especially when close to the ground during takeoff and landing.

Surface friction plays an important role in the speed and direction of surface winds. The friction between the air and the ground slows the air down causing a lower wind speed than would be expected from the pressure gradient. The friction also changes the direction causing the wind to blow across the isobars toward the centre of a low pressure area and away from the centre of a high pressure area.

The effect of surface friction usually does not extend more than a couple of thousand feet into the air. At 3 000 feet above the ground, the wind blows parallel to the isobars with a speed proportional to the pressure gradient.

Hills and valleys substantially distort the airflow associated with the prevailing pressure system and the pressure gradient. Katabatic and anabatic winds and mountain waves are examples of wind phenomena in mountainous areas.

**Katabatic and Anabatic Winds**

Show slides of Figures A-1 and A-2.

At night, the sides of hills cool by radiation. The air in contact with them becomes cooler and denser, and blows down the slope into the valley. A katabatic wind is the term for down slope winds flowing from high elevations down the slopes to valleys below. If the slopes are covered with ice and snow, the katabatic wind can also carry the cold dense air into the warmer valleys during the day.

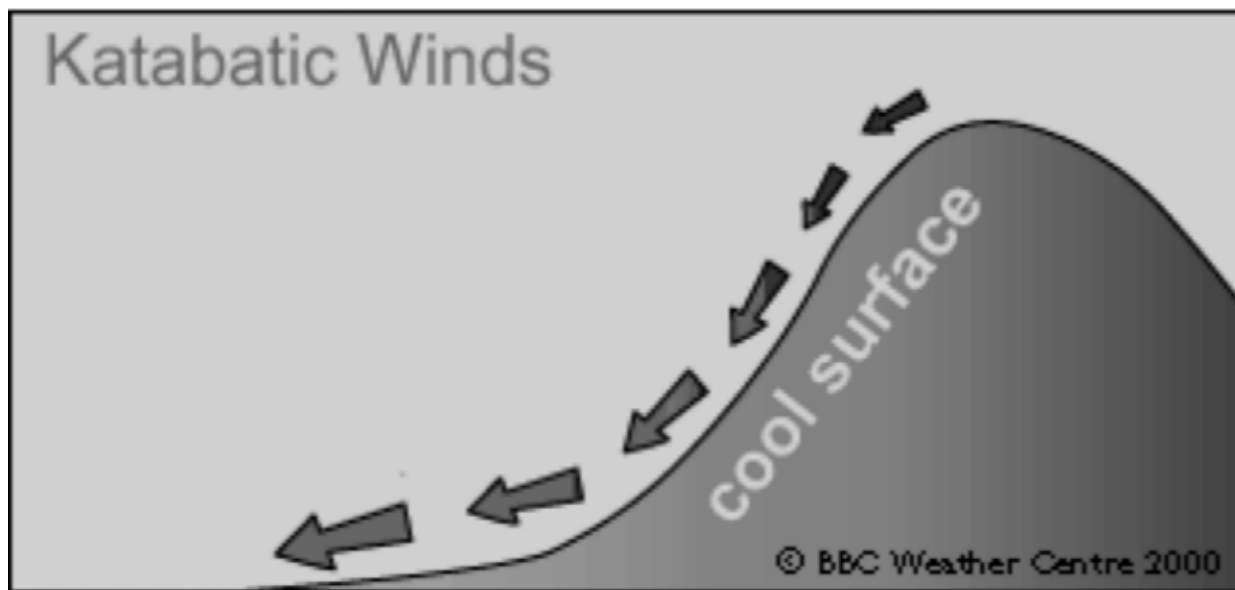

Figure 1 Katabatic Wind

*Note.* From "Wind", by BBC, 2008. Copyright 2000 by BBC Weather Centre. Retrieved October 14, 2008, from [http://www.bbc.co.uk/weather/weatherwise/factfiles/basics/wind\\_localwinds.shtml](http://www.bbc.co.uk/weather/weatherwise/factfiles/basics/wind_localwinds.shtml)

Anabatic wind occurs during the day when the slopes of hills, not covered by snow, are warmed. The air in contact with them becomes warmer and less dense, therefore flowing up the slope.

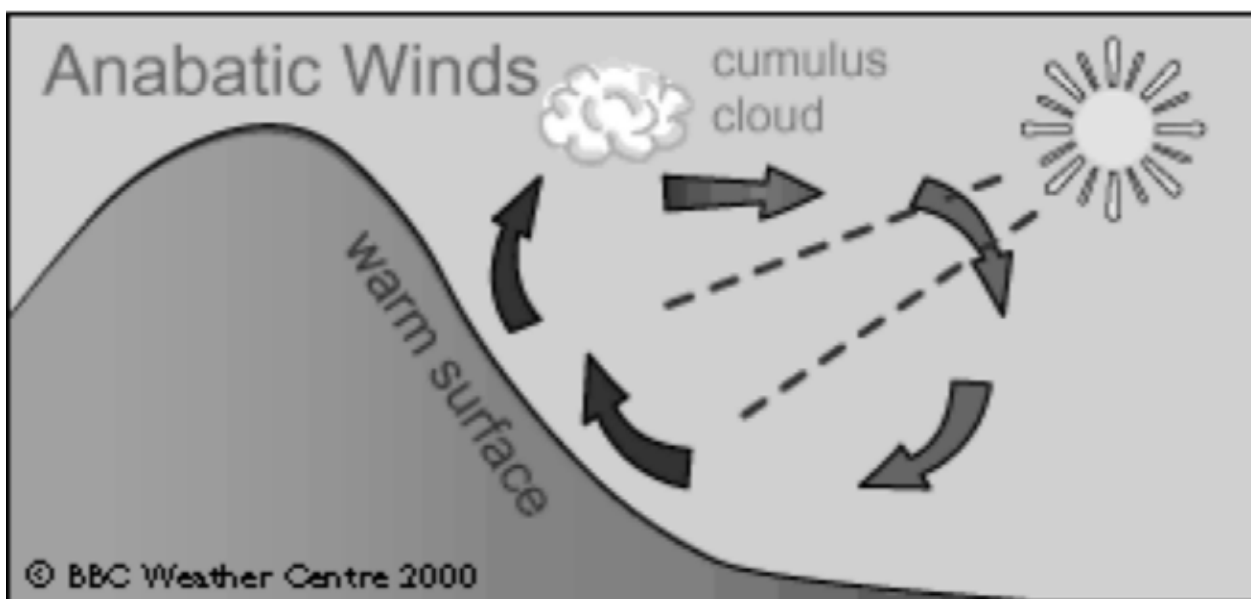

Figure 2 Anabatic Wind

*Note.* From "Wind", by BBC, 2008. Copyright 2000 by BBC Weather Centre. Retrieved October 14, 2008, from [http://www.bbc.co.uk/weather/weatherwise/factfiles/basics/wind\\_localwinds.shtml](http://www.bbc.co.uk/weather/weatherwise/factfiles/basics/wind_localwinds.shtml)

## Mountain Waves



Show slide of Figure A-3.

Air flowing across a mountain range usually rises smoothly up the slope of the range. Once over the top, it pours down the other side with considerable force, bouncing up and down, creating eddies and turbulence. It also creates powerful vertical waves that may extend for great distances downwind of the mountain range. This phenomenon is known as a mountain wave. The most severe mountain wave conditions are created in strong airflows that are blowing at right angles to the mountain range in very unstable air.

If the air mass has high moisture content, clouds of a very distinctive appearance will develop, thereby serving as a warning to pilots. Orographic lift causes a cap cloud to form along the top of the ridge. Lenticular (lens-shaped) clouds form in the wave crests aloft and lie in bands that may extend well above 40 000 feet. Rotor clouds resemble a long line of stratocumulus clouds and form in the rolling eddies downstream.

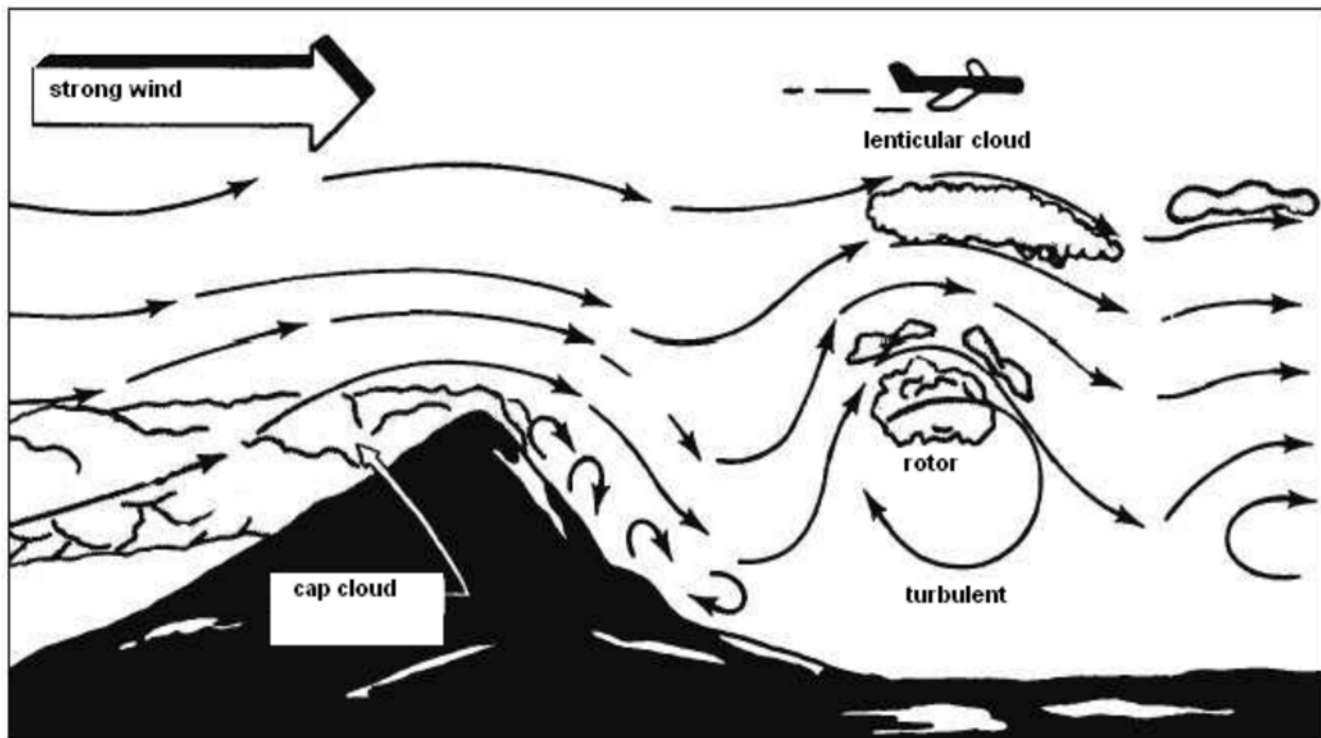

Figure 3 Mountain Wave

*Note.* From "Integrated Publishing", 2003. *Aerographer / Meteorology*, Copyright 2003 by Integrated Publishing. Retrieved October 14, 2008, from <http://www.tpub.com/weather2/3-25.htm>

Mountain waves may cause many dangers to aircraft, such as:

- common downdrafts of 2 000 feet per minute along the downward slope;
- extremely severe turbulence in the air layer between the ground and the tops of the rotor clouds;
- severe wind shear due to wind speed variation between the crests and troughs of the waves;



- severe icing due to large supercooled droplets sustained in the strong vertical currents; and
- an altimeter error of more than 3 000 feet on the high side due to the increase in wind speed and accompanying decrease in pressure.

### Gusts

A gust is a rapid and irregular change of wind speed and may be associated with a rapid change in wind direction. Gusts are caused by mechanical turbulence that results from friction between the air and the ground and by the unequal heating of the earth's surface, particularly during hot summer afternoons.



Wind gusts are a hazard to gliders due to their light weight and relatively slow stalling speed. Therefore, the Air Cadet Gliding Program has a maximum permissible gust differential of 10 knots (12 mph). Any gust differential beyond this will require an immediate shutdown of gliding operations.

### Squalls

A squall is a sudden increase in the strength of the wind of longer duration than a gust and like a gust, may be accompanied by a rapid change of wind direction. Squalls may be caused by the passage of a fast moving cold front or thunderstorm.

---

## CONFIRMATION OF TEACHING POINT 1

### QUESTIONS:

- Q1. Explain anabatic wind.
- Q2. What types of clouds are caused by mountain waves?
- Q3. What causes gusts?

### ANTICIPATED ANSWERS:

- A1. Anabatic wind occurs during the day when the slopes of hills not covered by snow are warmed. The air in contact with them becomes warmer and less dense, therefore flowing up the slope.
- A2. Cap clouds, lenticular clouds, and rotor clouds.
- A3. Gusts are caused by mechanical turbulence that results from friction between the air and the ground and by the unequal heating of the earth's surface.

---

## Teaching Point 2

**Describe jet streams.**

Time: 10 min

Method: Interactive Lecture

---

## JET STREAMS



Show slides of Figures A-4 and A-5.

Jet streams are narrow bands of exceedingly high speed winds that exist in the higher levels of the atmosphere at altitudes ranging from 20 000 to 40 000 feet or more. They flow from west to east and are usually 300 nautical miles wide and 3 000 to 7 000 feet thick. Winds in the central core of a jet stream are generally between 100 and 150 knots, although they may reach speeds as great as 250 knots.

The northern hemisphere has two such streams: the mid-latitude (polar) jet, which is the one usually affecting weather in North America, Europe and Asia, and the subtropical jet.

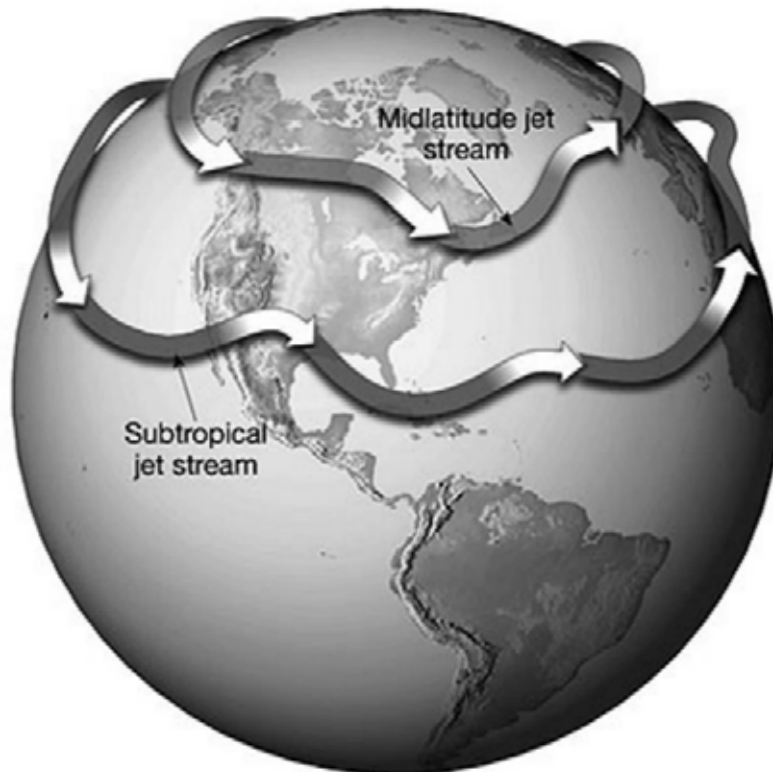

Figure 4 The Jet Stream

*Note.* From "Remote Sensing Tutorial", by N. Short, 2005, *Federation of American Scientists*. Retrieved February 26, 2009, from [http://www.fas.org/irp/imint/docs/rst/Sect14/Sect14\\_1c.html](http://www.fas.org/irp/imint/docs/rst/Sect14/Sect14_1c.html)

When the mid-latitude jet is farther north, in Canada, the weather to its south tends to be mild or at least less cold. When the stream swings south well within the United States (U.S.), especially in winter, very cold, often harsh weather prevails at the surface on the northern side.

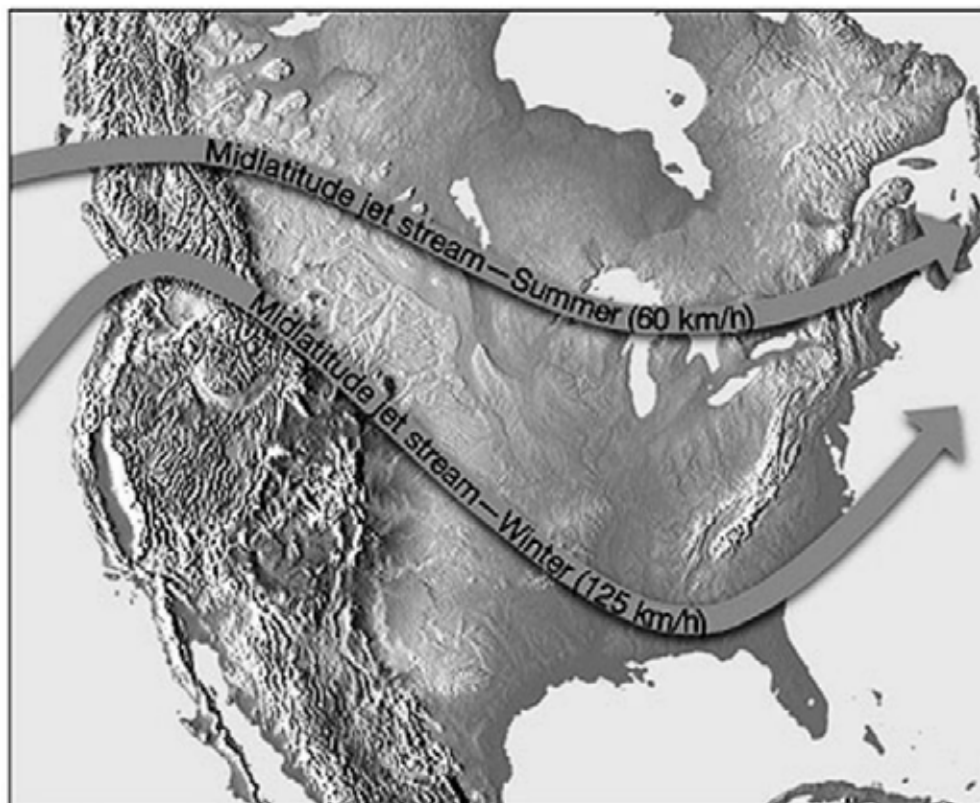

Figure 5 Seasonal Mid-Latitude Jet Stream

*Note.* From "Remote Sensing Tutorial", by N. Short, 2005, *Federation of American Scientists*. Retrieved February 26, 2009, from [http://www.fas.org/irp/imint/docs/rst/Sect14/Sect14\\_1c.html](http://www.fas.org/irp/imint/docs/rst/Sect14/Sect14_1c.html)

Knowing the location of a jet stream is important when planning long range flights at high altitudes. For example, on an eastbound flight a pilot would want to take advantage of the excellent tail winds a jet stream would provide. On a westbound flight they would want to avoid the winds.

### **Clear Air Turbulence (CAT)**

CAT is a bumpy, turbulent condition that occurs in a cloudless sky. It occurs at high altitudes, usually above 15 000 feet and is more severe near 30 000 feet. The most probable place to expect CAT is just above the central core of a jet stream.

CAT is almost impossible to forecast and can be severe enough to be a hazard to modern high-performance airplanes. Therefore, knowledge of areas in which CAT is most likely to occur is important for pilots to help minimize encounters with it.

## **CONFIRMATION OF TEACHING POINT 2**

### **QUESTIONS:**

- Q1. What are jet streams?
- Q2. In what direction do jet streams flow?
- Q3. Where is clear air turbulence most likely to occur?

**ANTICIPATED ANSWERS:**

- A1. Jet streams are narrow bands of exceedingly high speed winds that exist in the higher levels of the atmosphere at altitudes ranging from 20 000 to 40 000 feet or more.
- A2. Jet streams flow from west to east.
- A3. Clear air turbulence is most likely to occur just above the central core of a jet stream.
- 

**END OF LESSON CONFIRMATION**

**QUESTIONS:**

- Q1. What must pilots be aware of when close to the ground during takeoff and landing?
- Q2. List examples of wind phenomena in mountainous areas.
- Q3. What is the range of wind speeds in the central core of the jet stream?

**ANTICIPATED ANSWERS:**

- A1. The direction and speed of wind.
- A2. Examples include:
- katabatic winds,
  - anabatic winds, and
  - mountain waves.
- A3. 100 to 150 knots but may reach speeds as great as 250 knots.
- 

**CONCLUSION**

---

**HOMEWORK / READING / PRACTICE**

Nil.

**METHOD OF EVALUATION**

This EO is assessed IAW A-CR-CCP-804/PG-001, *Proficiency Level Four Qualification Standard and Plan*, Chapter 3, Annex B, Aviation Subjects–Combined Assessment PC.

**CLOSING STATEMENT**

Wind is a major factor in flight planning and flight characteristics. Pilots must constantly be aware of the direction and speed of wind during all parts of the flight. Knowledge of winds is essential for future aviation training and for instructional duties at the squadron.

**INSTRUCTOR NOTES / REMARKS**

Cadets who are qualified Advanced Aviation may assist with this instruction.

---

**REFERENCES**

---

C3-116 ISBN 0-9680390-5-7 MacDonald, A. F., & Pepler, I. L. (2000). *From the ground up: Millennium edition*. Ottawa, ON: Aviation Publishers Co. Limited.

C3-334 Short, N. (2005). Remote Sensing Tutorial. *Federation of American Scientists*. Retrieved February 26, 2009, from [http://www.fas.org/irp/imint/docs/rst/Sect14/Sect14\\_1c.html](http://www.fas.org/irp/imint/docs/rst/Sect14/Sect14_1c.html)

THIS PAGE INTENTIONALLY LEFT BLANK

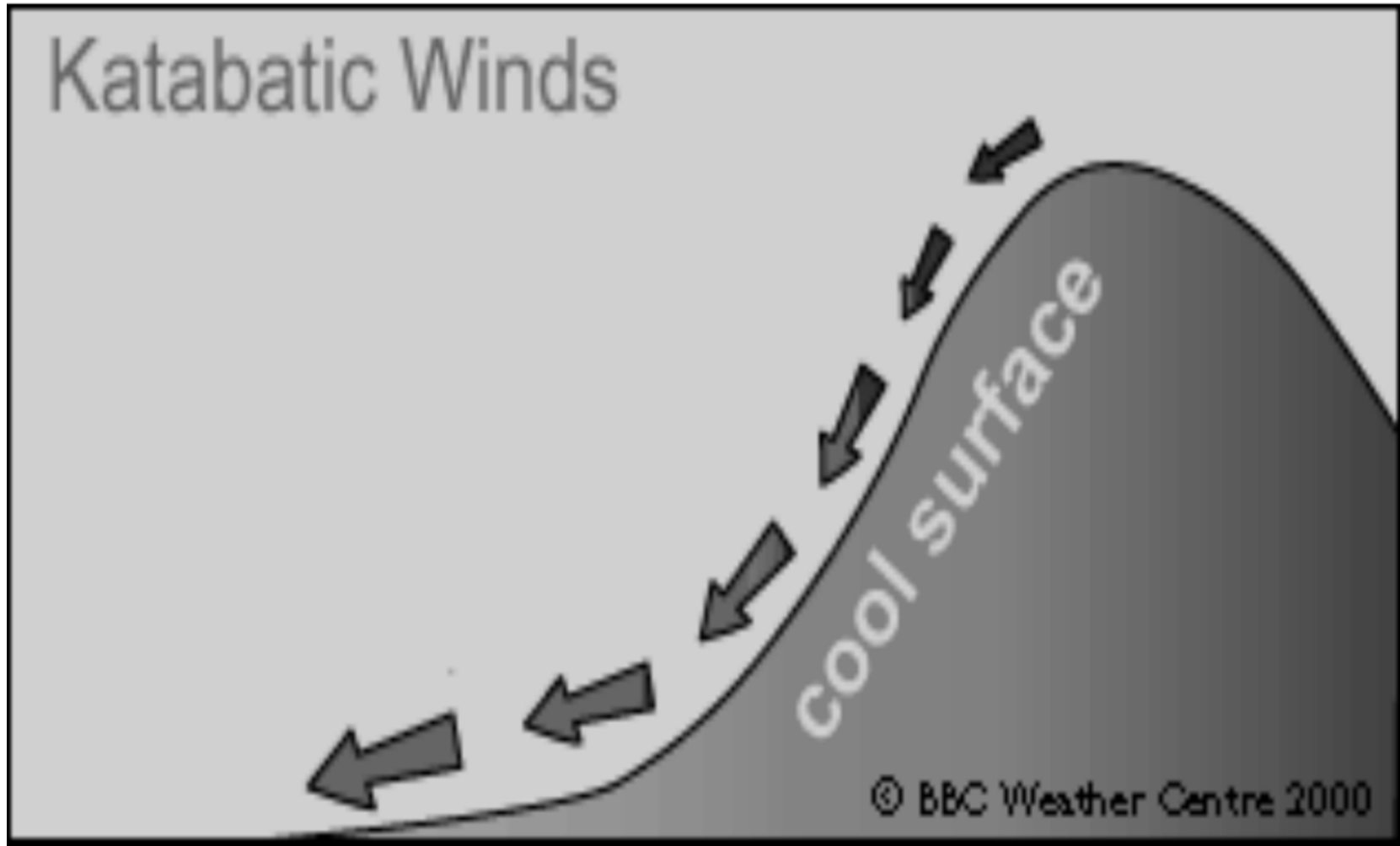

Figure A-1 Katabatic Wind

*Note.* From "Wind", by BBC, 2008. Copyright 2000 by BBC Weather Centre. Retrieved October 14, 2008, from [http://www.bbc.co.uk/weather/weatherwise/factfiles/basics/wind\\_localwinds.shtml](http://www.bbc.co.uk/weather/weatherwise/factfiles/basics/wind_localwinds.shtml)

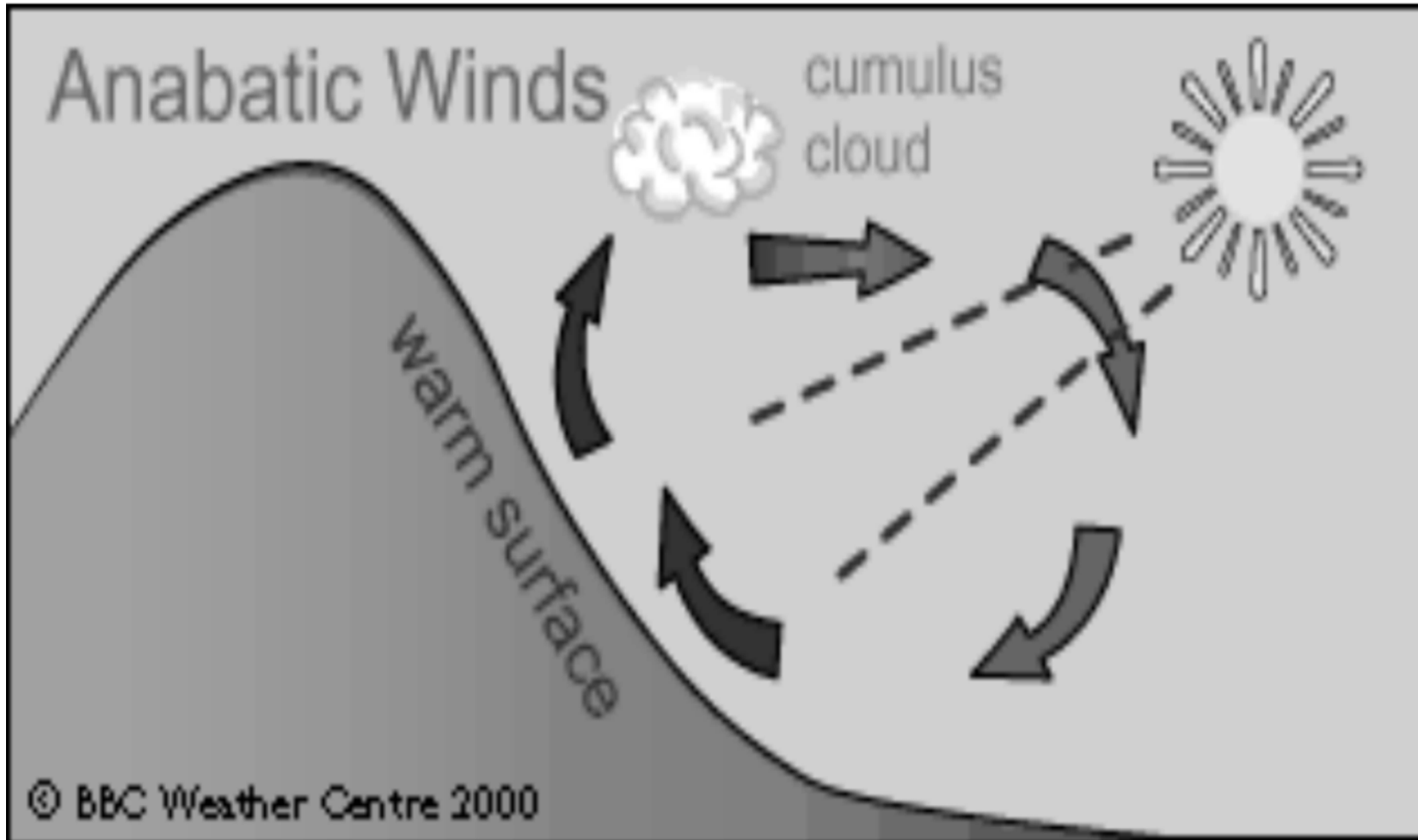

Figure A-2 Anabatic Wind

*Note.* From "Wind", by BBC, 2008. Copyright 2000 by BBC Weather Centre. Retrieved October 14, 2008, from [http://www.bbc.co.uk/weather/weatherwise/factfiles/basics/wind\\_localwinds.shtml](http://www.bbc.co.uk/weather/weatherwise/factfiles/basics/wind_localwinds.shtml)



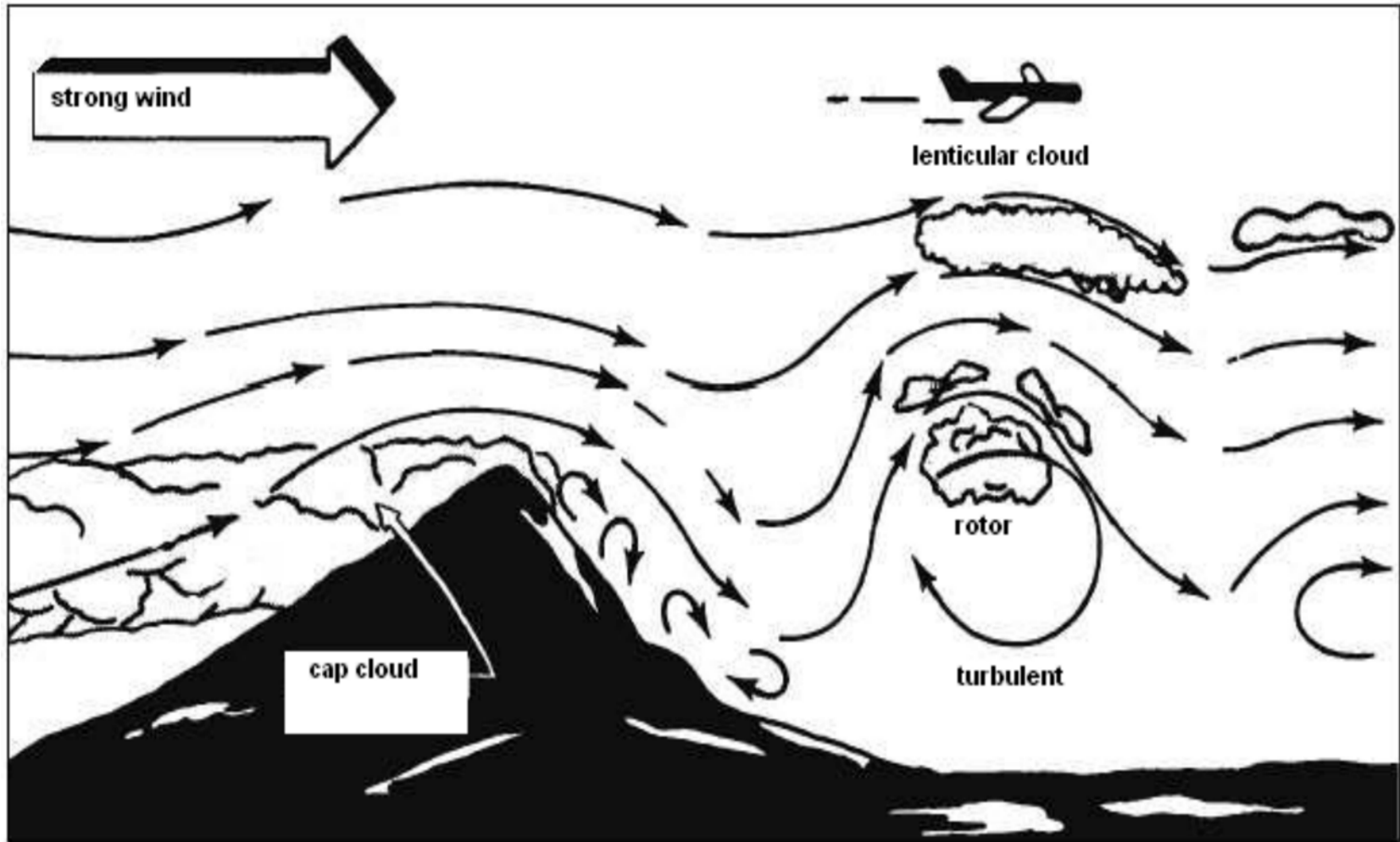

Figure A-3 Mountain Wave

Note. From "Integrated Publishing", 2003, *Aerographer / Meteorology*. Copyright 2003 by Integrated Publishing. Retrieved October 14, 2008, from <http://www.tpub.com/weather2/3-25.htm>

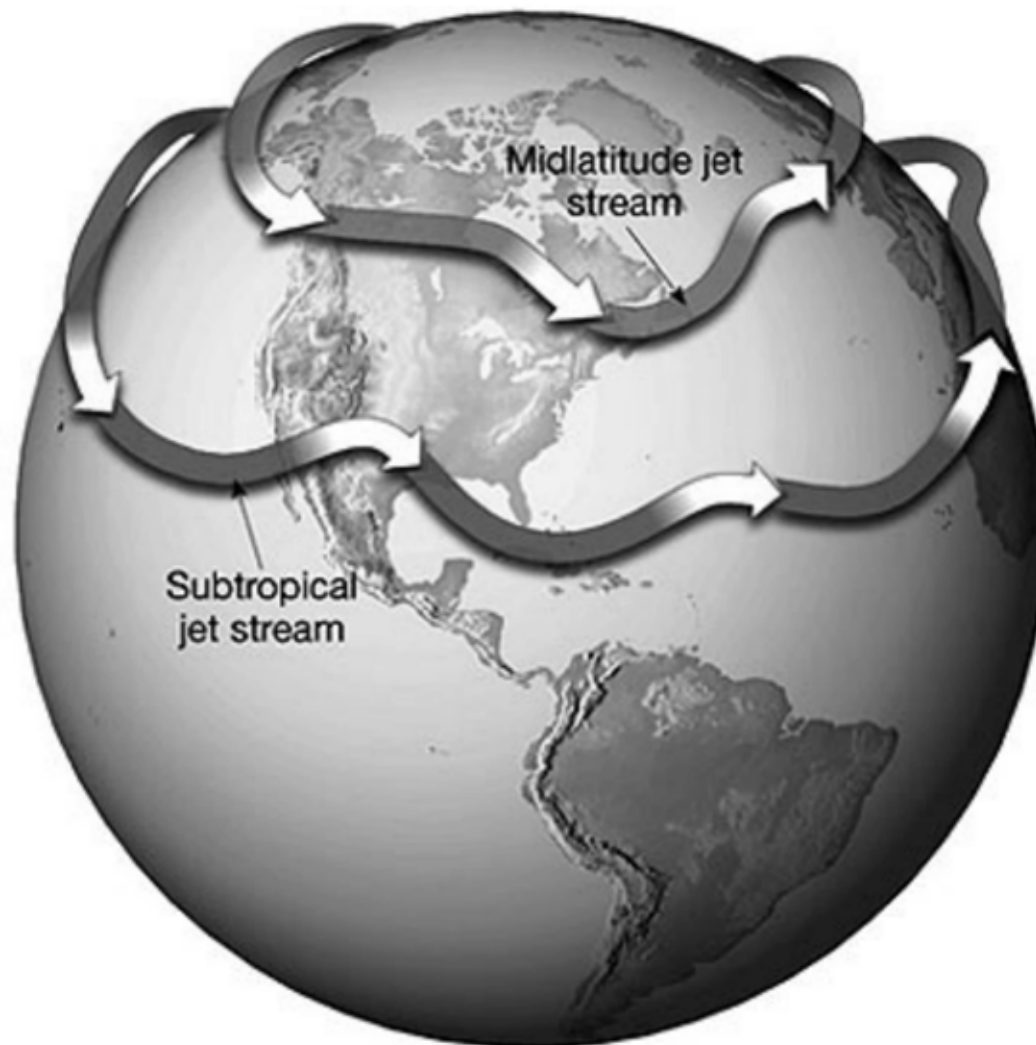

Figure A-4 The Jet Stream

*Note.* From "Remote Sensing Tutorial", by N. Short, 2005, *Federation of American Scientists*. Retrieved February 26, 2009, from [http://www.fas.org/irp/imint/docs/rst/Sect14/Sect14\\_1c.html](http://www.fas.org/irp/imint/docs/rst/Sect14/Sect14_1c.html)

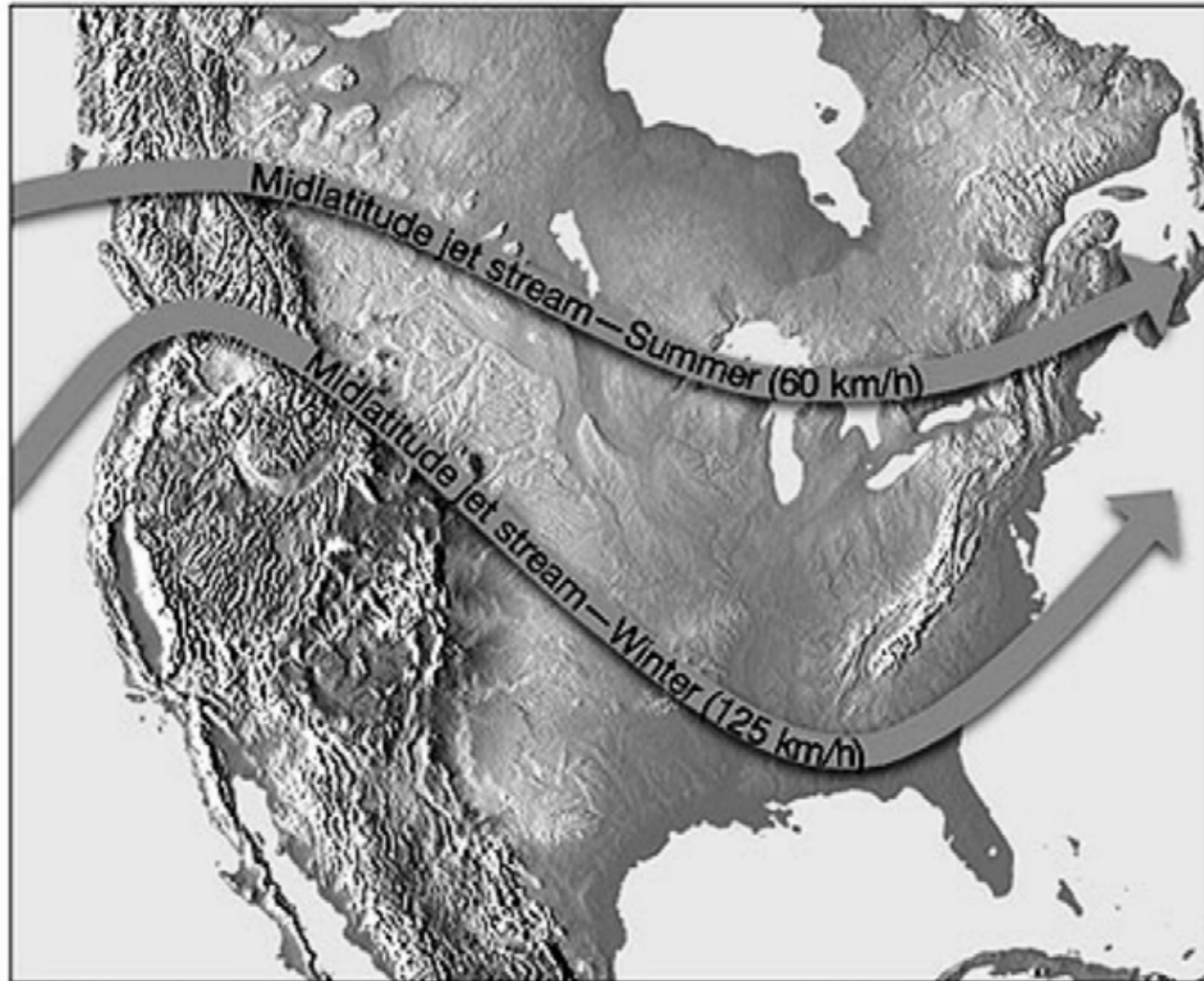

Figure A-5 Seasonal Mid-Latitude Jet Stream

*Note.* From "Remote Sensing Tutorial", by N. Short, 2005, *Federation of American Scientists*. Retrieved February 26, 2009, from [http://www.fas.org/irp/imint/docs/rst/Sect14/Sect14\\_1c.html](http://www.fas.org/irp/imint/docs/rst/Sect14/Sect14_1c.html)

THIS PAGE INTENTIONALLY LEFT BLANK



**ROYAL CANADIAN AIR CADETS  
PROFICIENCY LEVEL FOUR  
INSTRUCTIONAL GUIDE**



**SECTION 2**

**EO M436.02 – DESCRIBE AIR MASSES AND FRONTS**

---

Total Time:

90 min

---

**PREPARATION**

---

**PRE-LESSON INSTRUCTIONS**

Resources needed for the delivery of this lesson are listed in the lesson specification located in A-CR-CCP-804/PG-001, *Proficiency Level Four Qualification Standard and Plan*, Chapter 4. Specific uses for said resources are identified throughout the instructional guide within the TP for which they are required.

Review the lesson content and become familiar with the material prior to delivering the lesson.

Review and prepare the demonstration located at Attachment A.

Prepare the slides located at Attachments B and C.

Photocopy the handout located at Attachment D for each cadet.

Prepare the learning stations located at Attachments E–I.

Photocopy a set of the fronts worksheets located at Attachment J for each cadet.

**PRE-LESSON ASSIGNMENT**

Nil.

**APPROACH**

An interactive lecture was chosen for TPs 1 and 2 to orient the cadets to air masses and fronts and generate interest in the subject.

An in-class activity was chosen for TP 3 as it is an interactive way to present types of fronts and associated weather.

---

**INTRODUCTION**

---

**REVIEW**

Nil.

**OBJECTIVES**

By the end of this lesson the cadet shall be expected to describe air masses and fronts.

**IMPORTANCE**

It is important for cadets to describe air masses and fronts as knowledge of this material helps them to understand changes in weather conditions. Being able to describe air masses and fronts provides knowledge for potential instructional duties and is part of the fundamentals that cadets pursuing future aviation training will require.

---

**Teaching Point 1****Explain weather in an air mass.**

Time: 10 min

Method: Interactive Lecture

---

**WEATHER IN AN AIR MASS**

There are three main factors that determine the weather in an air mass:

- moisture content,
- the cooling process, and
- the stability of the air.

**Moisture Content**

Continental air masses are very dry and little cloud develops. The high moisture content in maritime air may cause cloud, precipitation, and fog.

**The Cooling Process**

Even if the air is moist, condensation and cloud formation only occur if the temperature is lowered to the dewpoint. The cooling processes that contribute to condensation and the formation of clouds are:

- contact with a surface cooling by radiation,
- advection over a colder surface, and
- expansion brought about by lifting.

Cloud formation within an air mass is not uniform. For example, clouds may form in an area where the air is undergoing orographic lift even though the rest of the air mass is clear.

**The Stability of the Air**

In stable air, stratus cloud and poor visibility are common, whereas in unstable air, cumulus cloud and good visibility are common.

**Characteristics of Cold Air Masses and Warm Air Masses**

Cold air masses (eg, arctic and polar air masses) will typically have the following characteristics:

- instability,
- turbulence,
- good visibility,
- cumuliform clouds, and
- precipitation in the form of showers, hail, and thunderstorms.

Warm air masses (eg, tropical air masses) will typically have the following characteristics:

- stability,
- smooth air,
- poor visibility,

- stratiform clouds and fog, and
- precipitation in the form of drizzle.

---

## CONFIRMATION OF TEACHING POINT 1

### QUESTIONS:

- Q1. What are the three main factors that determine weather in an air mass?
- Q2. What are the cooling processes that contribute to condensation and the formation of clouds?
- Q3. What are the characteristics of a warm air mass?

### ANTICIPATED ANSWERS:

- A1. Moisture content, the cooling process, and the stability of the air.
- A2. Contact with a surface cooling by radiation, advection over a colder surface, and expansion brought about by lifting.
- A3. Stability, smooth air, poor visibility, stratiform clouds and fog, and precipitation in the form of drizzle.

---

## Teaching Point 2

## Define and explain types of fronts.

Time: 15 min

Method: Interactive Lecture

---

## FRONTS

A front is the transition zone between two air masses. The interaction of air masses along their frontal zones is responsible for weather changes.



Conduct the demonstration outlined at Attachment A to illustrate the mixing of warm and cold air masses:

1. Allow the cadets to move closer so they can observe what will happen.
2. Have the cadets predict what will happen when the divider is removed.
3. Observe the action between the red and blue colored water.



The blue-dyed water represents a cold air mass and the red-dyed water represents a warm air mass. The area where these two air masses meet and mix is a front.



Show the slides located at Attachment B as fronts are presented.



The blue water (colder and more dense) will slide underneath the warmer water which is the same that occurs to the air.



Figure 1 Cold Front

*Note.* From Remote Sensing Tutorial by N. Short, 2005, *Federation of American Scientists*. Retrieved February 26, 2009, from [http://www.fas.org/irp/imint/docs/rst/Sect14/Sect14\\_1c.html](http://www.fas.org/irp/imint/docs/rst/Sect14/Sect14_1c.html)

The cold air mass is more dense and therefore sinks, undercutting the warm air which will ascend over the cold air.



Figure 2 Warm Front

*Note.* From Remote Sensing Tutorial by N. Short, 2005, *Federation of American Scientists*. Retrieved February 26, 2009, from [http://www.fas.org/irp/imint/docs/rst/Sect14/Sect14\\_1c.html](http://www.fas.org/irp/imint/docs/rst/Sect14/Sect14_1c.html)



Show the slides located at Attachment C as front symbols are presented.

An air mass is a large section of the troposphere with uniform properties of temperature and moisture in the horizontal. An air mass can be several thousands of kilometers across and takes on the properties from the surface over which it formed.

Formation over ice and snow of the arctic will be dry and cold. Formation over the South Pacific will be warm and moist. Formation over a large body of water is moist and is referred to as maritime air. An air mass over a large land area is dry and is referred to as continental air.

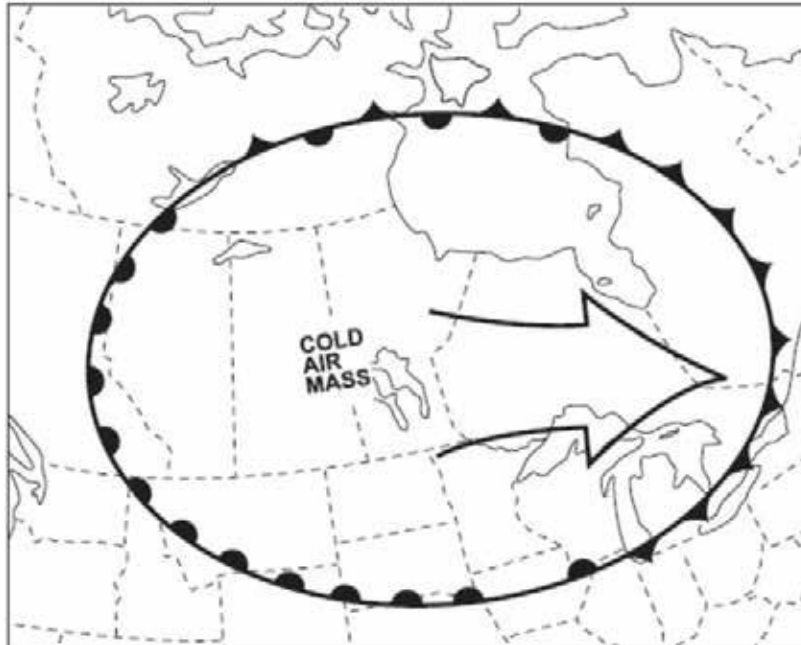



Figure 3 Air Masses and Fronts

Note. From *Air Command Weather Manual* (p. 6-8), 2004, Winnipeg, MB: Wing Publishing Office. Copyright 2004 by Her Majesty the Queen in Right of Canada.



Distribute the handout located at Attachment D to each cadet. Cadets will label each symbol as the information is presented.

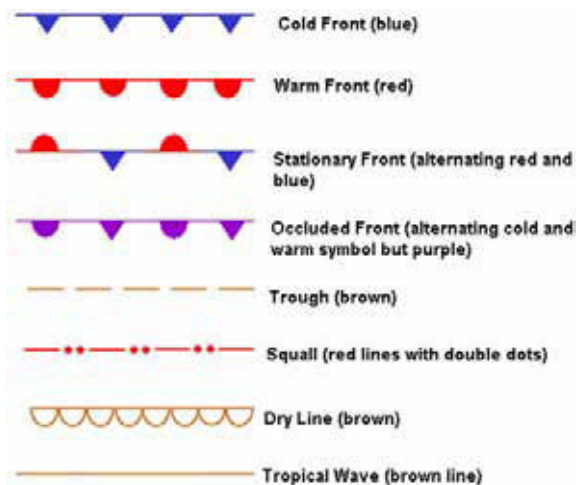

Figure 4 Front Symbols

Note. From "Weather", About.com, by R Oblanck, Copyright 2009 by The New York Times Company. Retrieved February 27, 2009 from [http://weather.about.com/od/frontsandairmasses/qt/front\\_symbols.htm](http://weather.about.com/od/frontsandairmasses/qt/front_symbols.htm)

---

**CONFIRMATION OF TEACHING POINT 2****QUESTIONS:**

- Q1. Define a front.
- Q2. What does the interaction of air masses along their frontal zones cause?
- Q3. Explain what happens when a cold air mass and a warm air mass meet.

**ANTICIPATED ANSWERS:**

- A1. A front is the transition zone between two air masses.
- A2. Changes in the weather.
- A3. The air in a cold air mass is more dense and therefore sinks, undercutting the warm air. The air in a warm air mass will ascend over the cold air.

---

**Teaching Point 3****Conduct an in-class activity to describe types of fronts and associated weather.**

Time: 55 min

Method: In-Class Activity

---

**ACTIVITY****OBJECTIVE**

The objective of this activity is to have the cadets identify different types of fronts and their associated weather.

**RESOURCES**

- Pen / pencil,
- Coloured pencils / markers,
- Fronts information sheets located at Attachments E–I, and
- Fronts worksheets located at Attachment J.

**ACTIVITY LAYOUT**

Set up and clearly mark five learning stations, located at Attachments E–I.

**ACTIVITY INSTRUCTIONS**

1. Distribute all five fronts worksheets and a pen / pencil to each cadet.
2. Divide the cadets into groups of two or three and place each group at one of the learning stations.
3. Have the cadets fill out the appropriate fronts worksheet for that station.



At learning stations with more than one diagram the cadet can choose which one to draw.

4. After nine minutes have the groups rotate to the next station until each group has completed all five stations.
5. Review the fronts worksheets as a class and answer any questions.

### **SAFETY**

Nil.

---

### **CONFIRMATION OF TEACHING POINT 3**

The cadets' participation in the activity will serve as the confirmation of this TP.

---

### **END OF LESSON CONFIRMATION**

#### **QUESTIONS:**

- Q1. What are the characteristics of a cold air mass?
- Q2. What clouds indicate the passing of a warm front?
- Q3. What is the term for the wedge-shaped mass of warm air lying above the colder air masses in an occluded front?

#### **ANTICIPATED ANSWERS:**

- A1. Instability, turbulence, good visibility, cumuliform clouds, and precipitation in the form of showers, hail, and thunderstorms.
  - A2. Cirrus, cirrostratus, altostratus, nimbostratus, and stratus.
  - A3. Trowal.
- 

### **CONCLUSION**

---

### **HOMEWORK / READING / PRACTICE**

Nil.

### **METHOD OF EVALUATION**

This EO is assessed IAW A-CR-CCP-804/PG-001, *Proficiency Level Four Qualification Standard and Plan*, Chapter 3, Annex B, Aviation Subjects–Combined Assessment PC.

### **CLOSING STATEMENT**

There are two basic types of weather: air mass and frontal. Knowledge of air masses and fronts is crucial for understanding weather patterns and making accurate predictions of changing weather conditions. This knowledge is essential for future aviation training and for potential instructional duties at the squadron.

### **INSTRUCTOR NOTES / REMARKS**

It is recommended that the three periods required for this EO be scheduled consecutively.

Cadets who are qualified Advanced Aviation may assist with this instruction.

---

**REFERENCES**

---

A3-044 CFACM 2-700 Air Command. (2001). *Air Command weather manual*. Ottawa, ON: Department of National Defence.

C3-116 ISBN 0-9680390-5-7 MacDonald, A. F., & Pepler, I. L. (2000). *From the ground up: Millennium edition*. Ottawa, ON: Aviation Publishers Co. Limited.

C3-334 Short, N. (2005). "Remote Sensing Tutorial". *Federation of American Scientists*. Retrieved February 26, 2009, from [http://www.fas.org/irp/imint/docs/rst/Sect14/Sect14\\_1c.html](http://www.fas.org/irp/imint/docs/rst/Sect14/Sect14_1c.html)

THIS PAGE INTENTIONALLY LEFT BLANK

### WARM AND COLD FRONT DEMONSTRATION OUTLINE

1. Fill a thermos / cooler / bottle with warm water and another with cold water.



Figure A-1 Air Mass Equipment

*Note.* Created by Director Cadets 3, 2009, Ottawa, ON: Department of National Defence

2. Add a few drops of red food colouring to the bottle with warm water.
3. Add a few drops of blue food colouring to the bottle with cold water.
4. Shake / stir each bottle to evenly mix the colouring and water.
5. Place the empty jars together to ensure an exact match.
6. Fill one jar to almost overflowing with blue-dyed water and the other jar with red-dyed water.



Figure A-2 Jars Filled

*Note.* Created by Director Cadets 3, 2009, Ottawa, ON: Department of National Defence

7. Place an index card or a plastic coated paper on the top of the warm (red-dyed) water jar and press down around the edges of the jar to make a seal.



Figure A-3 Card Over Red Jar

*Note.* Created by Director Cadets 3, 2009, Ottawa, ON: Department of National Defence

8. Place the warm water jar over the top of the cold water jar so that the edges meet.



Figure A-4 Jars Stacked with Card Inserted

*Note.* Created by Director Cadets 3, 2009, Ottawa, ON: Department of National Defence



9. Have an assistant gently remove the paper once the jars are stacked on each other, keeping the jars together (do this over a sink or container to catch any water that may leak out).



Figure A-5 Jars Stacked with Card Removed

*Note.* Created by Director Cadets 3, 2009, Ottawa, ON: Department of National Defence

10. Keeping one hand on each jar, slowly turn the jars to one side while holding the centre together.



Figure A-6 Turn Jars on Side

*Note.* Created by Director Cadets 3, 2009, Ottawa, ON: Department of National Defence

11. Observe the action between the red and blue colored water.

THIS PAGE INTENTIONALLY LEFT BLANK

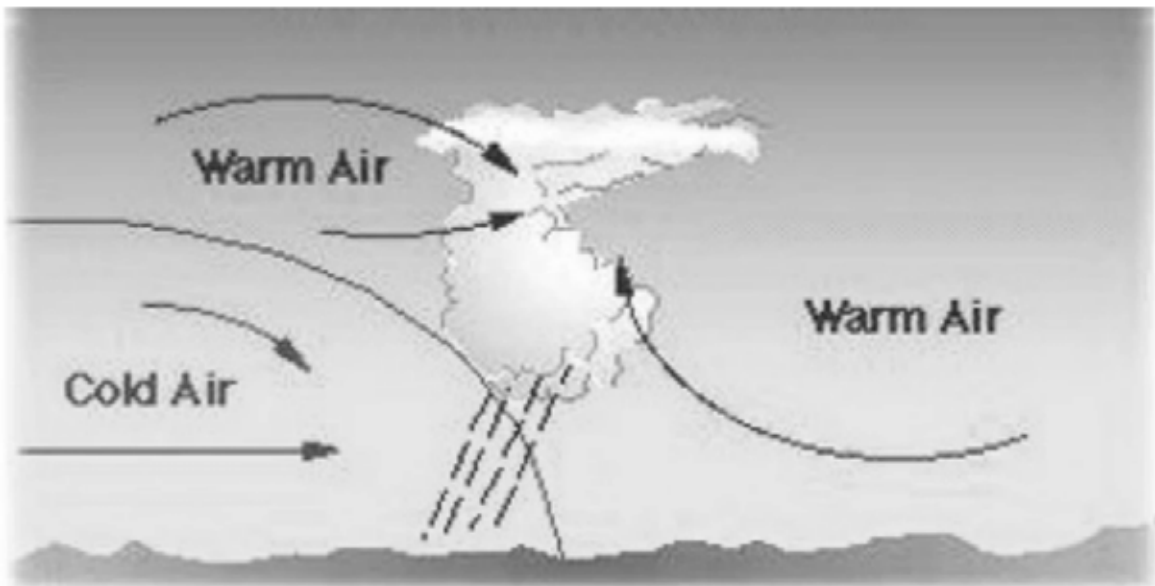

Figure B-1 Cold Front

*Note.* From Remote Sensing Tutorial by N. Short, 2005, *Federation of American Scientists*. Retrieved February 26, 2009, from [http://www.fas.org/irp/imint/docs/rst/Sect14/Sect14\\_1c.html](http://www.fas.org/irp/imint/docs/rst/Sect14/Sect14_1c.html)

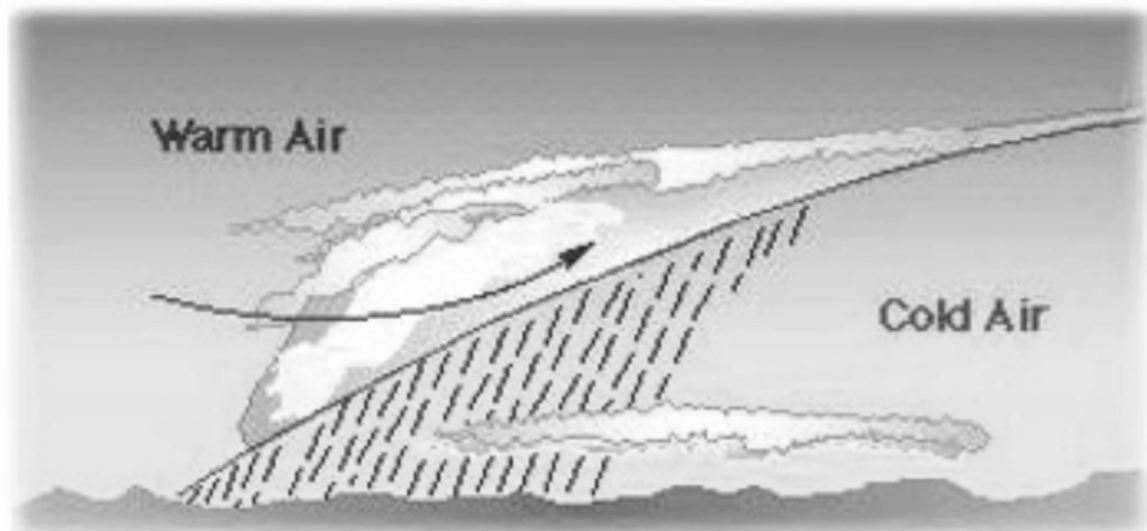

Figure B-2 Warm Front

*Note.* From Remote Sensing Tutorial by N. Short, 2005, *Federation of American Scientists*. Retrieved February 26, 2009, from [http://www.fas.org/irp/imint/docs/rst/Sect14/Sect14\\_1c.html](http://www.fas.org/irp/imint/docs/rst/Sect14/Sect14_1c.html)

THIS PAGE INTENTIONALLY LEFT BLANK

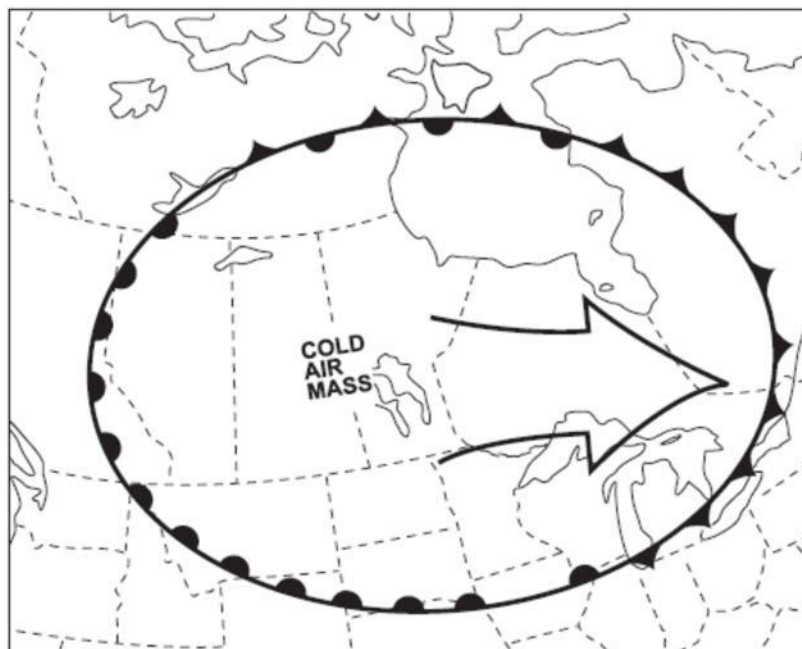

Figure C-1 Air Masses and Fronts

Note. From *Air Command Weather Manual* (p. 6-8), 2004, Winnipeg, MB: Wing Publishing Office. Copyright 2004 by Her Majesty the Queen in Right of Canada.

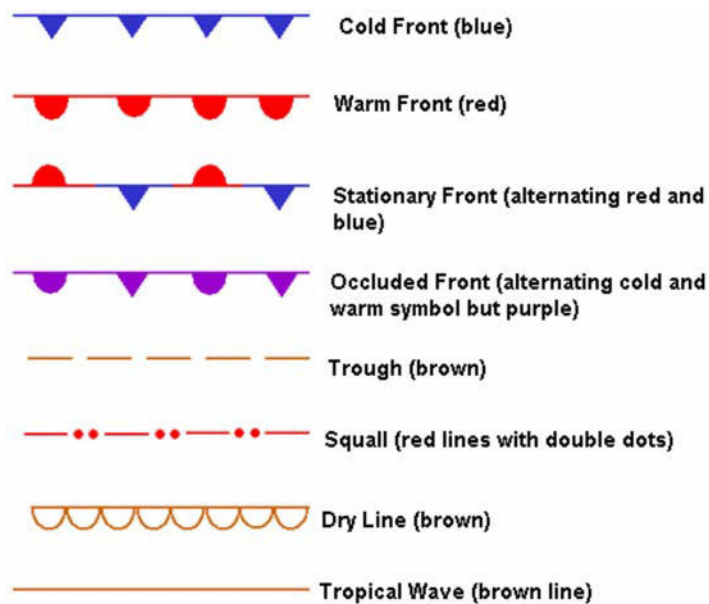
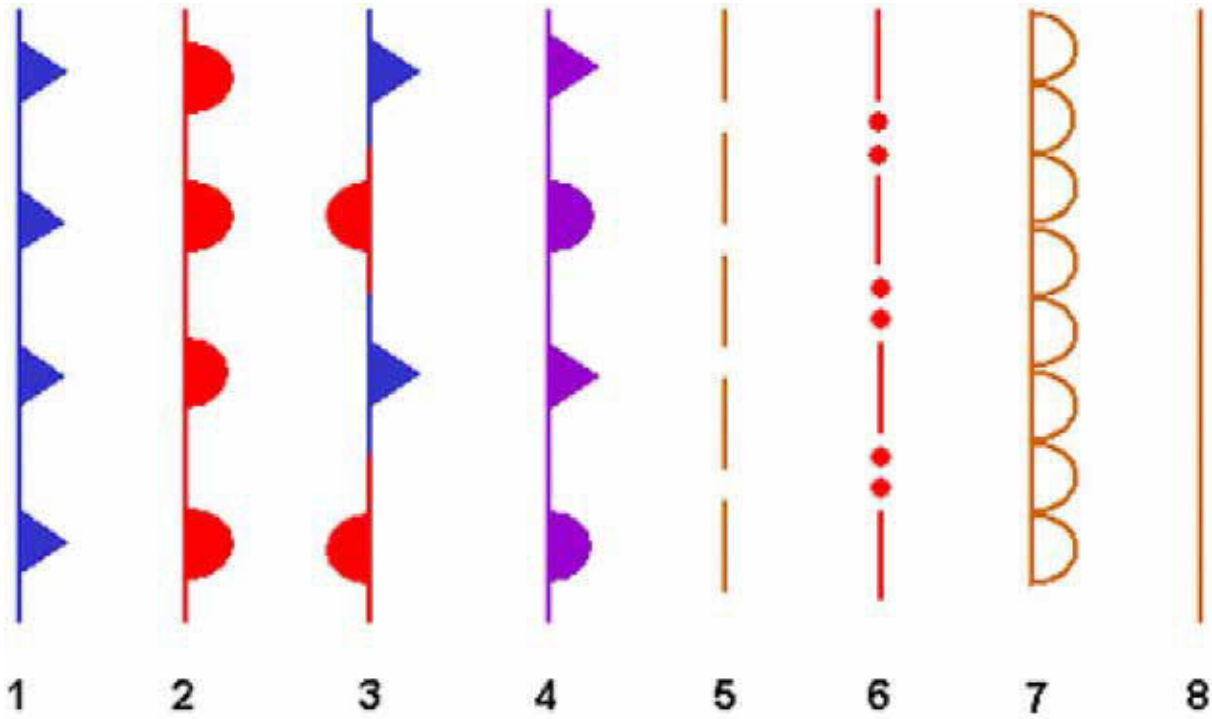

Figure C-2 Front Symbols

Note. From "Weather" About.com, by R Oblanck, Copyright 2009 by The New York Times Company. Retrieved February 27, 2009, from [http://weather.about.com/od/frontsandairmasses/qt/front\\_symbols.htm](http://weather.about.com/od/frontsandairmasses/qt/front_symbols.htm)

THIS PAGE INTENTIONALLY LEFT BLANK

### WEATHER MAP SYMBOLS



	Front	Colour
1	_____	_____
2	_____	_____
3	_____	_____
4	_____	_____
5	_____	_____
6	_____	_____
7	_____	_____
8	_____	_____

THIS PAGE INTENTIONALLY LEFT BLANK



## COLD FRONT

A cold front is the part of a frontal system along which cold air is advancing.

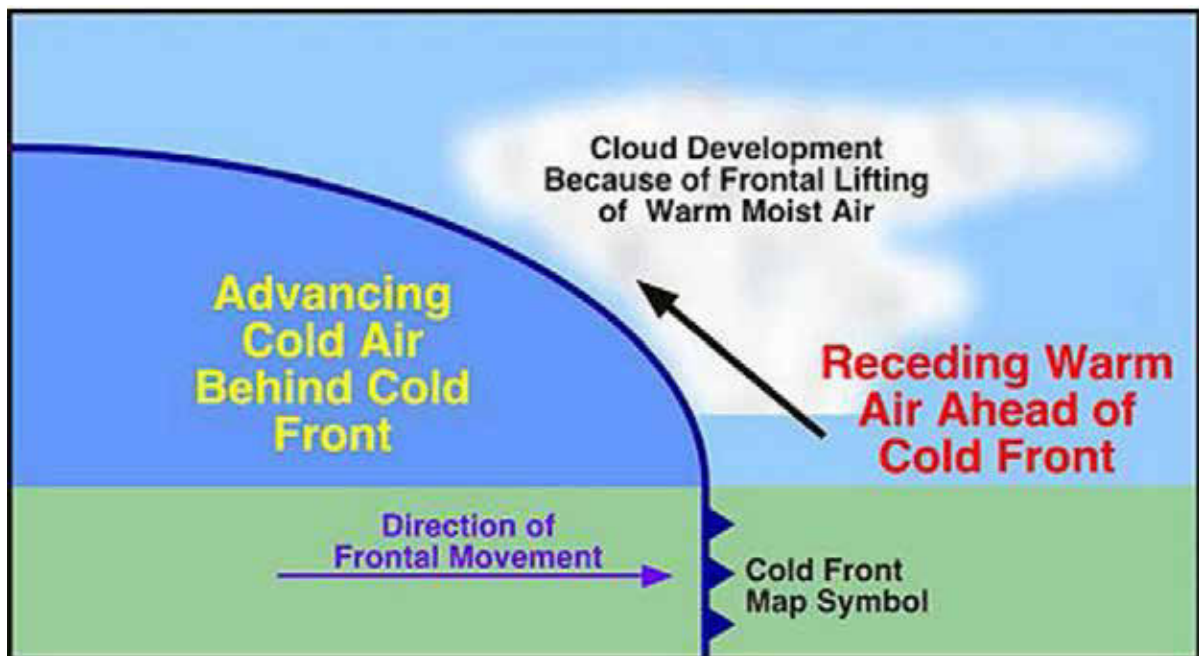

Figure E-1 Cold Front

*Note.* From Remote Sensing Tutorial by N. Short, 2005, *Federation of American Scientists*. Retrieved February 26, 2009, from [http://www.fas.org/irp/imint/docs/rst/Sect14/Sect14\\_1c.html](http://www.fas.org/irp/imint/docs/rst/Sect14/Sect14_1c.html)

When a mass of cold air overtakes a mass of warm air, the cold air, being denser, stays on the surface and undercuts the warm air violently. The slope of the advancing cold front is quite steep as surface friction slows the air at the surface, allowing the upper air to catch up. The rapid ascent of warm air gives rise to a relatively narrow band (only about 50 nautical miles) of cumuliform cloud that frequently builds up into violent thunderstorms.

The severity of the weather depends on the moisture content and stability of the warm air mass that the cold air mass is undercutting and the speed of the advancing cold front. If the warm air is very moist and unstable, towering cumulus clouds and thunderstorms are likely to develop, bringing heavy showers in the form of rain, snow, or hail. A slower moving cold front advancing on more stable and drier air will produce stratus or altocumulus clouds with light or no precipitation.

A squall line, a continuous line of thunderstorms, sometimes develops ahead of a fast moving cold front. The weather brought about by a squall line is extremely violent, including rapid shifts in wind, heavy rain or hail, and thunder and lightning. Pilots should avoid squall lines at all costs.

A sharp fall in temperature, a rise in pressure, and rapid clearing usually occur with the passage of the cold front.

THIS PAGE INTENTIONALLY LEFT BLANK

## WARM FRONT

A warm front is the part of a frontal system along which cold air is retreating.

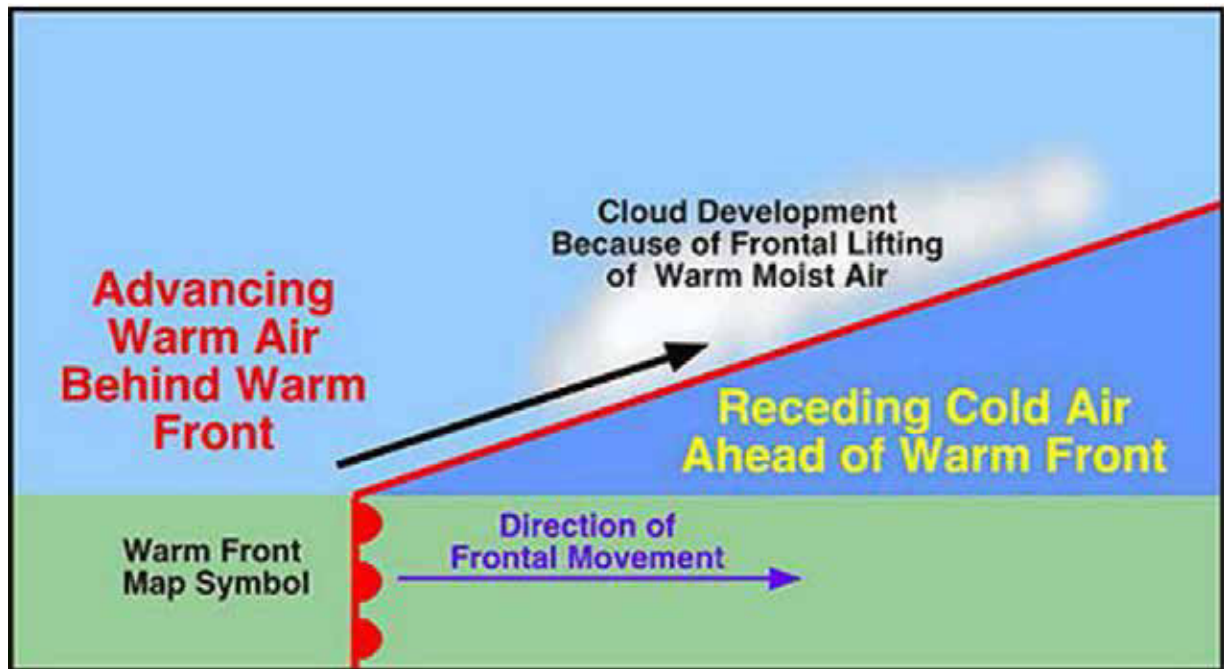

Figure F-1 Warm Front

*Note.* From Remote Sensing Tutorial by N. Short, 2005, *Federation of American Scientists*. Retrieved February 26, 2009, from [http://www.fas.org/irp/imint/docs/rst/Sect14/Sect14\\_1c.html](http://www.fas.org/irp/imint/docs/rst/Sect14/Sect14_1c.html)

As a mass of warm air advances on a retreating mass of cold air, the warm air, being lighter, ascends over the cold air in a long gentle slope. As a result of this long gentle slope and the relatively slow speed of warm fronts, the cloud formation associated with them may extend for 500 or more nautical miles in advance. If the warm air is moist and stable, these clouds develop in a distinctive sequence:

1. cirrus,
2. cirrostratus,
3. altostratus,
4. nimbostratus, and
5. stratus.

The clouds indicating the passing of a warm front can easily be remembered using the mnemonic "C-CANS".

If the warm air is moist and unstable, cumulonimbus and thunderstorms may be embedded in the stratiform layers, bringing heavy showers.

Warm fronts bring low ceilings and restricted visibility for a considerable length of time due to their slow movement.

In winter, when temperatures in the cold air are below freezing and temperatures in the lower levels of the warm air are above freezing, snow and freezing rain can be expected. Snow (SN) falls from the part of the warm air cloud that is high and therefore below freezing. Rain (RA) falls from the lower warm air cloud but becomes supercooled as it falls through the cold air mass. This creates freezing rain (FZRA) and ice pellets (PL). Therefore, icing is a problem associated with warm fronts in winter.

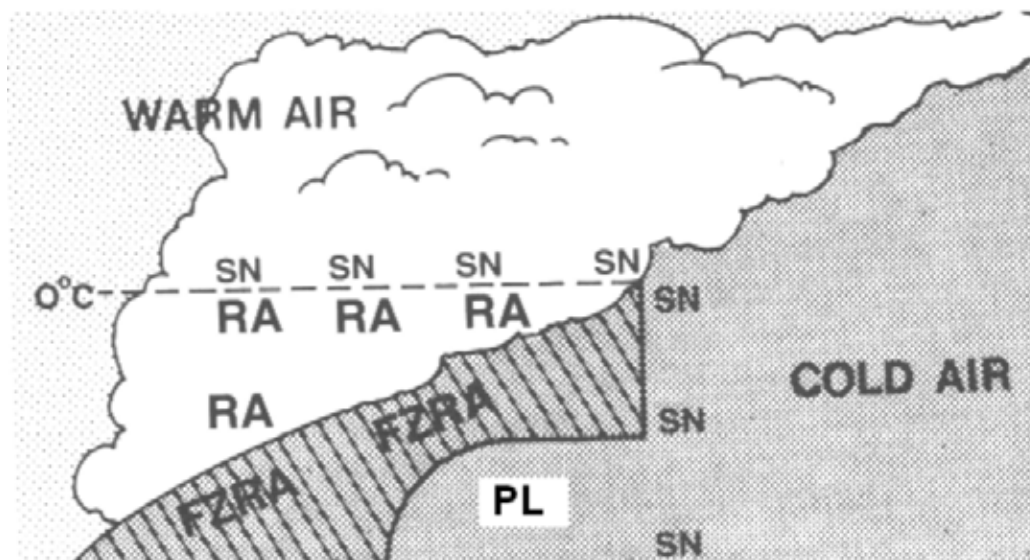

Figure F-2 Precipitation in a Warm Front in Winter

*Note.* From *From the Ground Up: Millennium Edition* (p. 145), by A. F. MacDonald and I. L. Peppler, 2000, Ottawa, ON: Aviation Publishers Co. Limited. Copyright 2000 by Aviation Publishers Co. Limited.

The passing of the warm front is marked by a rise of temperature due to the entry of the warm air, and the sky becoming relatively clear.

## STATIONARY FRONT

A stationary front is the part of a front along which the colder air is neither advancing nor retreating.

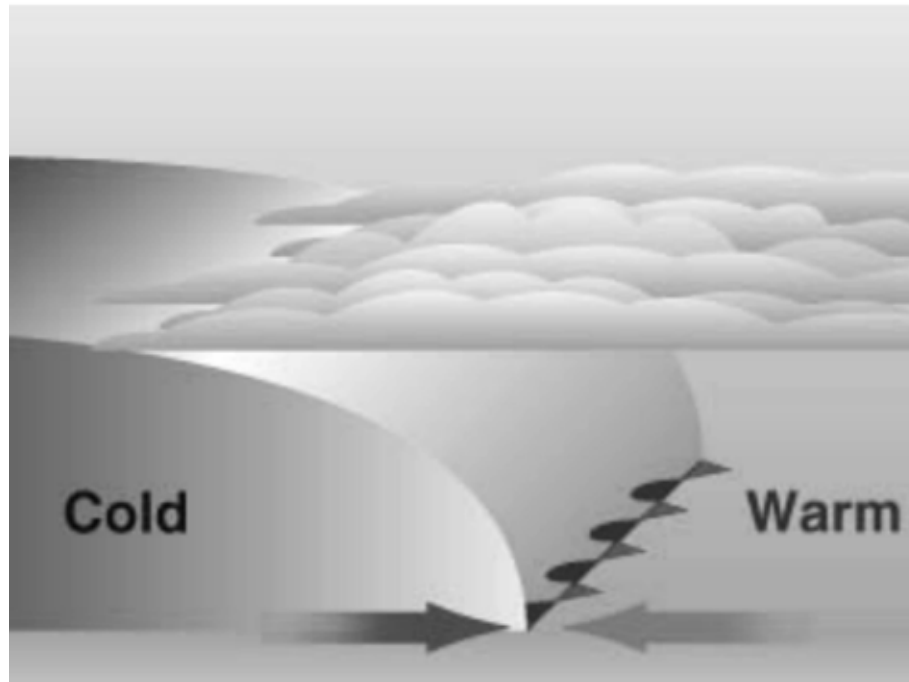

Figure G-1 Stationary Front

*Note.* From Geography for Kids, *KidsGeo.com*, Copyright 1998–2000. Retrieved October 17, 2008, from <http://www.kidsgeo.com/geography-for-kids/0129-stationary-fronts.php>

A stationary front occurs when the front does not move because the opposing air masses are of equal pressure. The weather conditions are similar to those associated with a warm front, (low cloud, and continuous rain or drizzle) although generally less intense and not so extensive. Usually a stationary front will weaken and eventually dissipate. Sometimes, however, it will begin to move after several days, becoming either a cold front or a warm front.

THIS PAGE INTENTIONALLY LEFT BLANK

## OCCLUDED FRONTS

A wave-like disturbance sometimes forms on a stationary front. This can develop into a small low known as a depression. As the depression forms, one section of the front begins to move as a warm front and the other section as a cold front. Over time, under certain atmospheric conditions, the cold front gradually overtakes the warm front and lifts the warm air entirely from the ground forming a single occluded front. Basically, the cold air catches up with itself as it flows around the low pressure area.

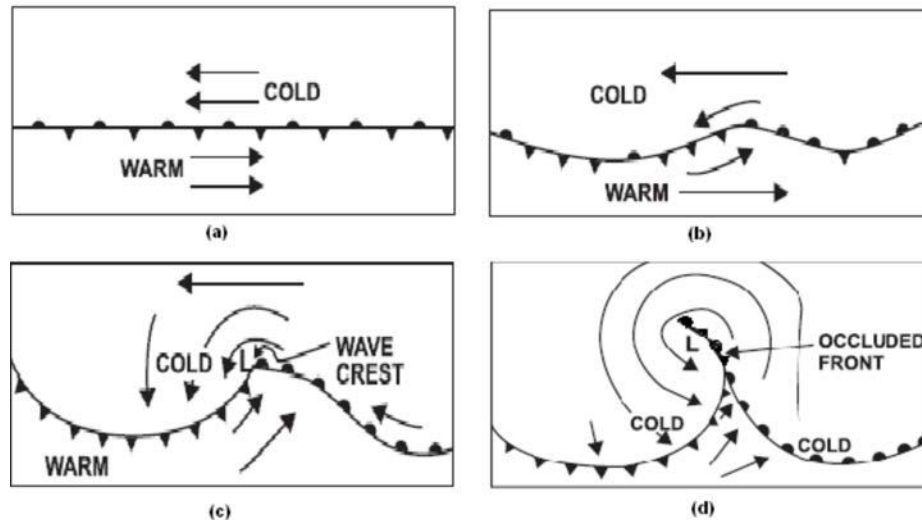

Figure H-1 Occluded Front Formation

*Note.* From *Air Command Weather Manual* (pp. 7-12 and 7-14), 2004, Winnipeg, MB: Wing Publishing Office. Copyright 2004 by Her Majesty the Queen in Right of Canada.

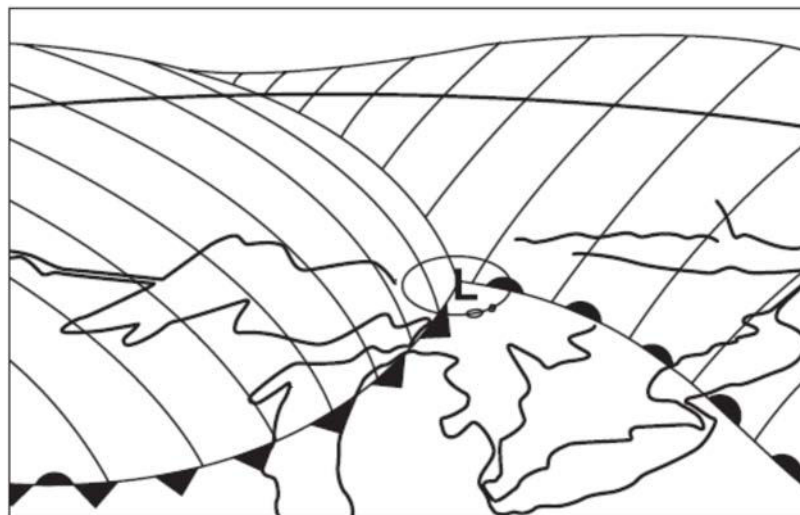

Figure H-2 Frontal Depression

*Note.* From *Air Command Weather Manual* (pp. 7-13), 2004, Winnipeg, MB: Wing Publishing Office. Copyright 2004 by Her Majesty the Queen in Right of Canada.

If the cold air is not as cold as the air it is overtaking (cool air advancing on cold air), the front is known as a warm occlusion.

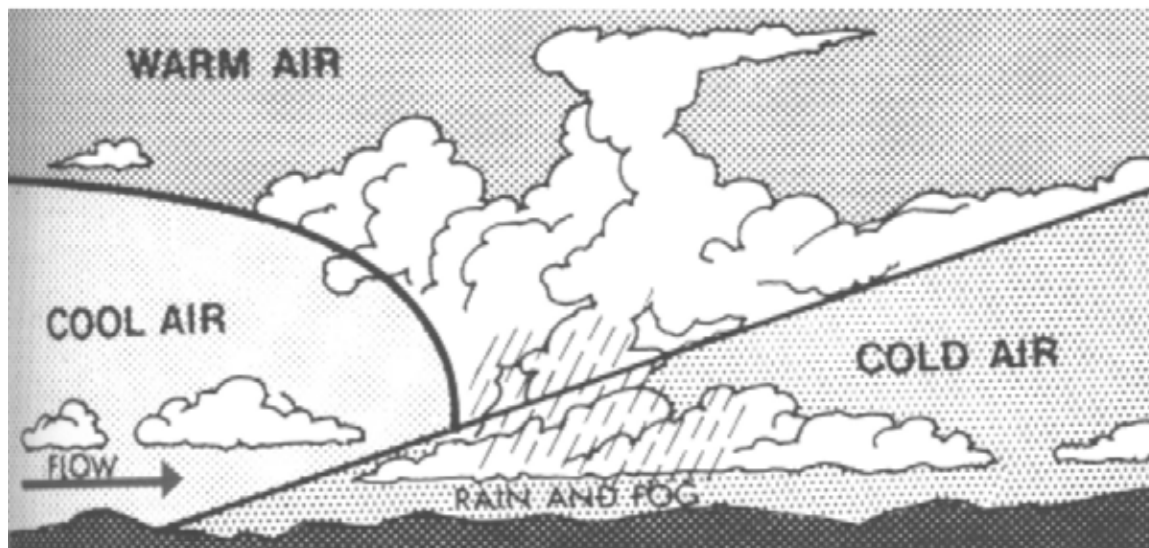

Figure H-3 Warm Occlusion

*Note.* From *From the Ground Up: Millennium Edition* (p. 143), by A. F. MacDonald and I. L. Peppler, 2000, Ottawa, ON: Aviation Publishers Co. Limited. Copyright 2000 by Aviation Publishers Co. Limited.

If the cold air is colder than the air it is overtaking (cold air advancing on cool air), the front is known as a cold occlusion.

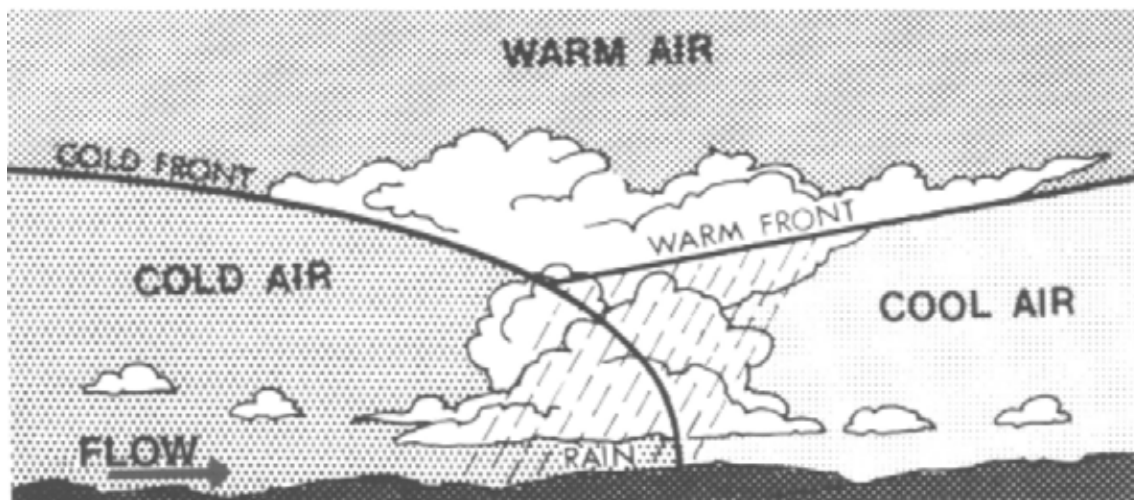

Figure H-4 Cold Occlusion

*Note.* From *From the Ground Up: Millennium Edition* (p. 143), by A. F. MacDonald and I. L. Peppler, 2000, Ottawa, ON: Aviation Publishers Co. Limited. Copyright 2000 by Aviation Publishers Co. Limited.

In both warm occlusions and cold occlusions, three air masses are present: a cool air mass, a cold air mass, and a warm air mass lying wedge-shaped over the colder air. The wedge-shaped mass of warm air is known as a trowal.



Both warm occlusions and cold occlusions have much the same characteristic as warm fronts, with low cloud and continuous rain. If the warm air is unstable, cumulonimbus clouds may develop; they are more likely to occur and bring about heavy turbulence, lightning, and icing in a cold occlusion.

THIS PAGE INTENTIONALLY LEFT BLANK

## UPPER FRONTS

An upper cold front can form in two ways:

- A cold front advancing across the country may encounter a shallow layer of colder air resting on the surface. The cold front will then leave the ground and ride up over the colder, heavier air.

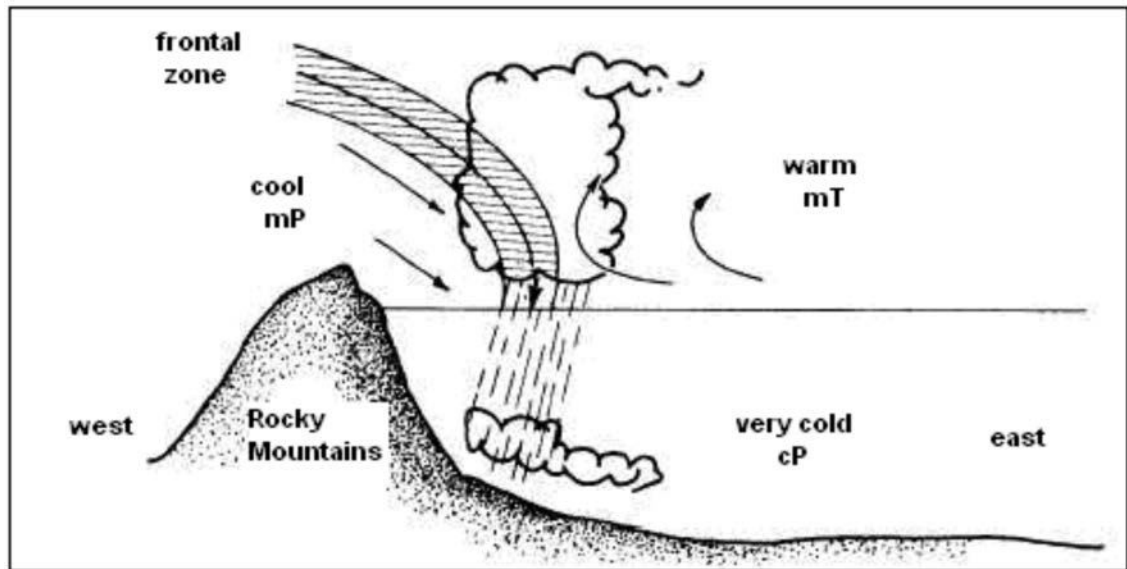

Figure I-1 Upper Cold Front

*Note.* From Integrated Publishing, *Aerographer / Meteorology*, Copyright 2003 by Integrated Publishing. Retrieved October 20, 2008, from [http://www.tpub.com/content/aerographer/14312/css/14312\\_121.htm](http://www.tpub.com/content/aerographer/14312/css/14312_121.htm)

- The structure of the advancing cold front is such that the cold air forms a shallow layer for some distance along the ground in advance of the main body of cold air. This causes the frontal surface of the main mass of cold air to be very steep. The line along which the frontal surface steepens is also known as an upper cold front.

An upper warm front can form in two ways:

- An advancing warm front rides up over a layer of cold air trapped on the ground. A change of air mass is not experienced on the ground because the front passes overhead.
- The surface of the cold air that is retreating ahead of an advancing warm front is almost flat for some distance ahead of the surface front and then steepens abruptly. The line along which the surface of the retreating cold air steepens sharply is also called an upper warm front.

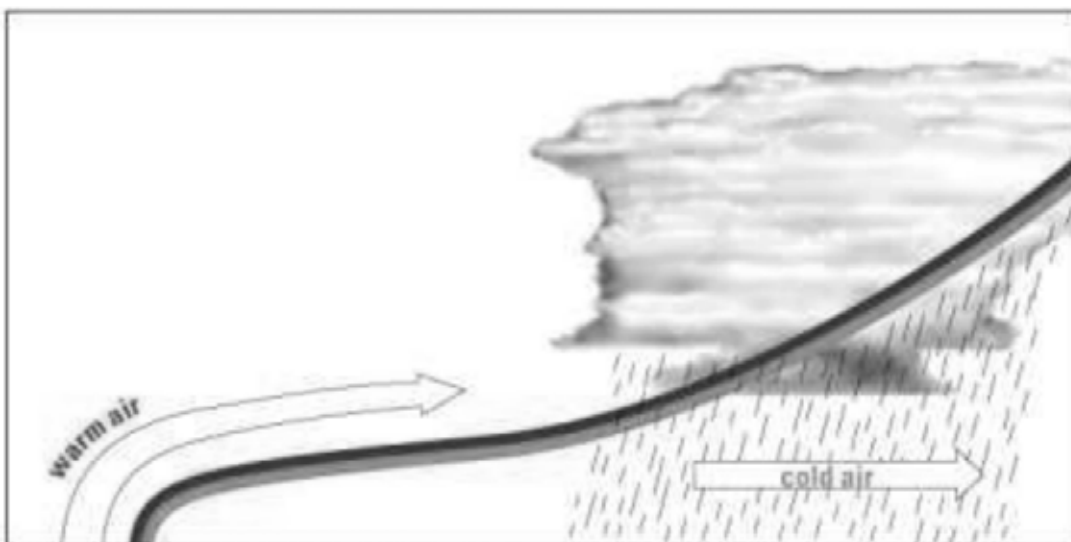

Figure I-2 Upper Warm Front

*Note.* From *Weather and Frontal Systems*, 2004, *Meteorological Services of Canada*. Copyright 2004 by Environment Canada. Retrieved October 20, 2008, from [http://www.qc.ec.gc.ca/meteo/Documentation/Temps\\_fronts\\_e.html](http://www.qc.ec.gc.ca/meteo/Documentation/Temps_fronts_e.html)

Weather in upper fronts can be particularly hazardous in winter. Similar to warm fronts, rain from the warmer air falls through the layer of cold air on the surface causing freezing rain and icing conditions.

## COLD FRONT

**DEFINITION:**

---

**ASSOCIATED WEATHER:**

---

---

---

---

---

**INTERESTING FACTS:**

---

---

---

---

---

**DIAGRAM:**



## WARM FRONT

### DEFINITION:

---

### ASSOCIATED WEATHER:

---

---

---

---

---

### INTERESTING FACTS:

---

---

---

---

---

### DIAGRAM:

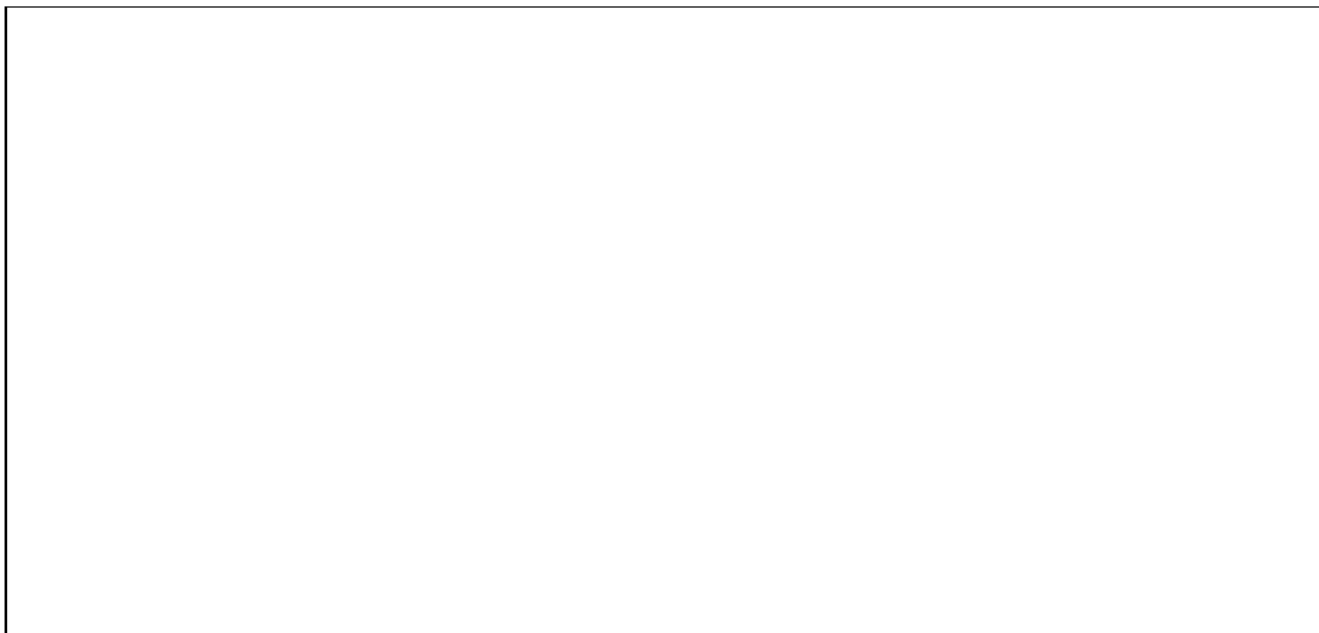

## STATIONARY FRONT

### DEFINITION:

---

### ASSOCIATED WEATHER:

---

---

---

---

---

### INTERESTING FACTS:

---

---

---

---

---

### DIAGRAM:

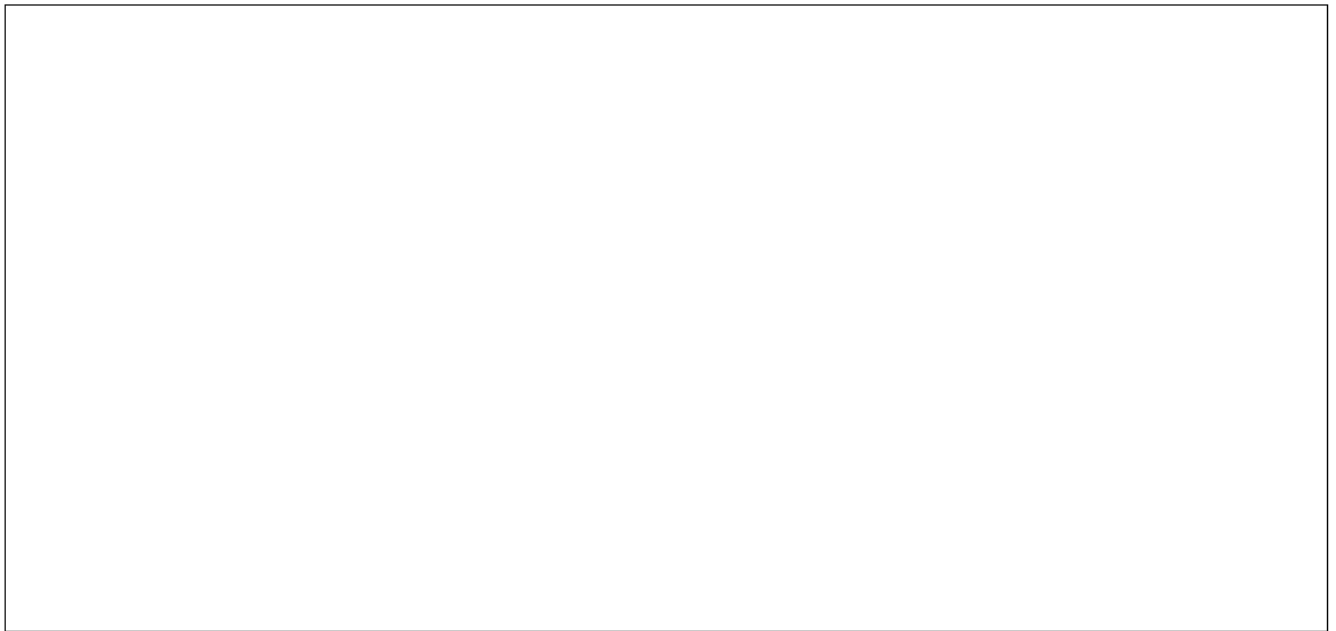

## OCCLUDED FRONTS

**DEFINITION OF WARM OCCLUSION:**

---

**DEFINITION OF COLD OCCLUSION:**

---

**ASSOCIATED WEATHER:**

---

---

---

**INTERESTING FACTS:**

---

---

---

---

**DIAGRAM:**



## UPPER FRONTS

### UPPER COLD FRONT FORMATION:

1.

---

---

2.

---

---

### UPPER WARM FRONT FORMATION:

1.

---

---

2.

---

---

### ASSOCIATED WEATHER:

---

---

---

### DIAGRAM:



THIS PAGE INTENTIONALLY LEFT BLANK



**ROYAL CANADIAN AIR CADETS  
PROFICIENCY LEVEL FOUR  
INSTRUCTIONAL GUIDE**



**SECTION 3**

**EO C436.01 – EXPLAIN FOG**

Total Time:

30 min

**PREPARATION**

**PRE-LESSON INSTRUCTIONS**

Resources needed for the delivery of this lesson are listed in the lesson specification located in A-CR-CCP-804/PG-001, *Proficiency Level Four Qualification Standard and Plan*, Chapter 4. Specific uses for said resources are identified throughout the instructional guide within the TP for which they are required.

Review the lesson content and become familiar with the material prior to delivering the lesson.

Acquire jars, strainers, and oven mitts (1 pair per group) for each group in TP 1.

Obtain three or four ice cubes for each group for TP 1.

Use a kettle(s) to boil water for each group for TP 1.

Prepare slides or handouts located at Attachment A.

**PRE-LESSON ASSIGNMENT**

Nil.

**APPROACH**

An in-class activity was chosen for this lesson as it is an interactive way to present the formation and types of fog.

**INTRODUCTION**

**REVIEW**

Nil.

**OBJECTIVES**

By the end of this lesson the cadet shall be expected to explain fog.

**IMPORTANCE**

Fog is one of the most common and persistent weather hazards encountered in aviation which impedes a pilot's visibility. Being able to explain fog provides knowledge for potential instructional duties and is part of the fundamentals that cadets pursuing future aviation training will require.

---

**Teaching Point 1**

**Have the cadets perform an experiment to illustrate the formation of fog.**

Time: 10 min

Method: In-Class Activity

---

**ACTIVITY**

**OBJECTIVE**

The objective of this activity is to have the cadet demonstrate how fog forms.

**RESOURCES**

- Glass jars,
- Strainers,
- Oven mitts,
- Kettle,
- Water,
- Rubbing alcohol, and
- Ice cubes.

**ACTIVITY LAYOUT**

Nil.

**ACTIVITY INSTRUCTIONS**

1. Divide the cadets into groups of two to four.
2. Use a kettle to boil water for each group.
3. Distribute resources to each group.
4. Briefly explain the steps of the experiment below and have the cadets make a hypothesis regarding the outcome.
5. Have each group perform the following experiment:
  - a. Fill the jar completely with hot water and let it stand for one minute.
  - b. Using oven mitts pour out all but 3 cm of water from the jar.
  - c. Add three to four drops of rubbing alcohol to water.
  - d. Put the strainer over the top of the jar.
  - e. Place three or four ice cubes in the strainer.
  - f. Observe the results.
6. Give the groups time to discuss what they have observed.
7. Ask the cadets to provide an explanation of what has happened.



The warm, moist air is cooled by the ice cubes to a temperature below its dewpoint, causing the water vapour to condense and form a cloud. A cloud in contact with the ground is called fog.

Fog can also form when the dewpoint is raised to the air temperature through the addition of water vapour.

The following are the ideal conditions for the formation of fog:

- an abundance of condensation nuclei,
- high relative humidity,
- a small temperature dewpoint spread, and
- some cooling process to initiate condensation.

Fog is usually dissipated by heating from below as sunlight filters down through the fog layer.

### SAFETY

- Warn the cadets the water is hot and may cause burns.
- Ensure the cadets use oven mitts and caution when pouring the hot water.

---

### CONFIRMATION OF TEACHING POINT 1

The cadets' participation in the activity will serve as the confirmation of this TP.

---

### Teaching Point 2

**Conduct an in-class activity to explain types of fog.**

Time: 15 min

Method: In-Class Activity

---

### ACTIVITY

#### OBJECTIVE

The objective of this activity is to have the cadets explain types of fog.

#### RESOURCES

- Flip chart paper,
- Flip chart markers, and
- *From the Ground Up: Millennium Edition.*

#### ACTIVITY LAYOUT

Arrange the classroom for group work.

## ACTIVITY INSTRUCTIONS

1. Divide the cadets into four groups.
2. Assign a leader in each group. The group leader will be responsible for assigning tasks to fellow cadets. Each group will need a recorder and at least one presenter.
3. Distribute flip chart paper and flip chart markers to each group.
4. Assign each group one of the following:
  - a. radiation fog,
  - b. advection fog,
  - c. upslope fog and steam fog, and
  - d. precipitation-induced fog and ice fog.
5. Have each group prepare a two-minute presentation on their type of fog using *From the Ground Up: Millennium Edition*, p. 147 as a reference.



Encourage the cadets to be creative and draw diagrams of the formation of their types of fog.

6. Have each group deliver their presentation.



Give handouts to each cadet or show slides located at Attachment A.

7. Answer any questions about the types of fog.



The types of fog can easily be remembered using the mnemonic "RAIS UP", as in "RAIS UP da roof".

## SAFETY

Nil.

---

## CONFIRMATION OF TEACHING POINT 2

### QUESTIONS:

- Q1. What conditions are ideal for the formation of radiation fog?
- Q2. The drifting of warm, moist air over a colder land or sea surface causes which type of fog?
- Q3. Explain the formation of steam fog.

**ANTICIPATED ANSWERS:**

- A1. Light wind, clear skies, and an abundance of condensation nuclei.
- A2. Advection fog.
- A3. Steam fog is formed when cold air passes over a warm water surface. Evaporation of the water into the cold air occurs until the cold air becomes saturated. The excess water vapour condenses as fog.
- 

**END OF LESSON CONFIRMATION****QUESTIONS:**

- Q1. What is fog?
- Q2. What are the two basic ways in which fog is formed?
- Q3. What type of fog is associated mostly with warm fronts?

**ANTICIPATED ANSWERS:**

- A1. Fog is a cloud in contact with the ground.
- A2. Fog is formed in the following ways:
- warm, moist air is cooled to a temperature below its dewpoint, causing the water vapour to condense and form a cloud; or
  - the dewpoint is raised to the air temperature through the addition of water vapour.
- A3. Precipitation-induced fog.
- 

**CONCLUSION****HOMEWORK / READING / PRACTICE**

Nil.

**METHOD OF EVALUATION**

Nil.

**CLOSING STATEMENT**

A good lookout is one of the most important aspects of airmanship when flying under Visual Flight Rules, making visibility from the cockpit a key factor in flight. Fog is one of the most common and persistent weather hazards encountered in aviation which impedes a pilot's visibility. An understanding of fog and the conditions under which it forms is essential for future aviation training.

**INSTRUCTOR NOTES / REMARKS**

Cadets who are qualified Advanced Aviation may assist with this instruction.

---

**REFERENCES**

---

C3-116 ISBN 0-9680390-5-7 MacDonald, A. F., & Pepler, I. L. (2000). *From the ground up: Millennium edition*. Ottawa, ON: Aviation Publishers Co. Limited.

C3-200 Weather Wiz Kids. (2008). *Make fog*. Retrieved September 26, 2008, from <http://www.weatherwizkids.com/fog.htm>



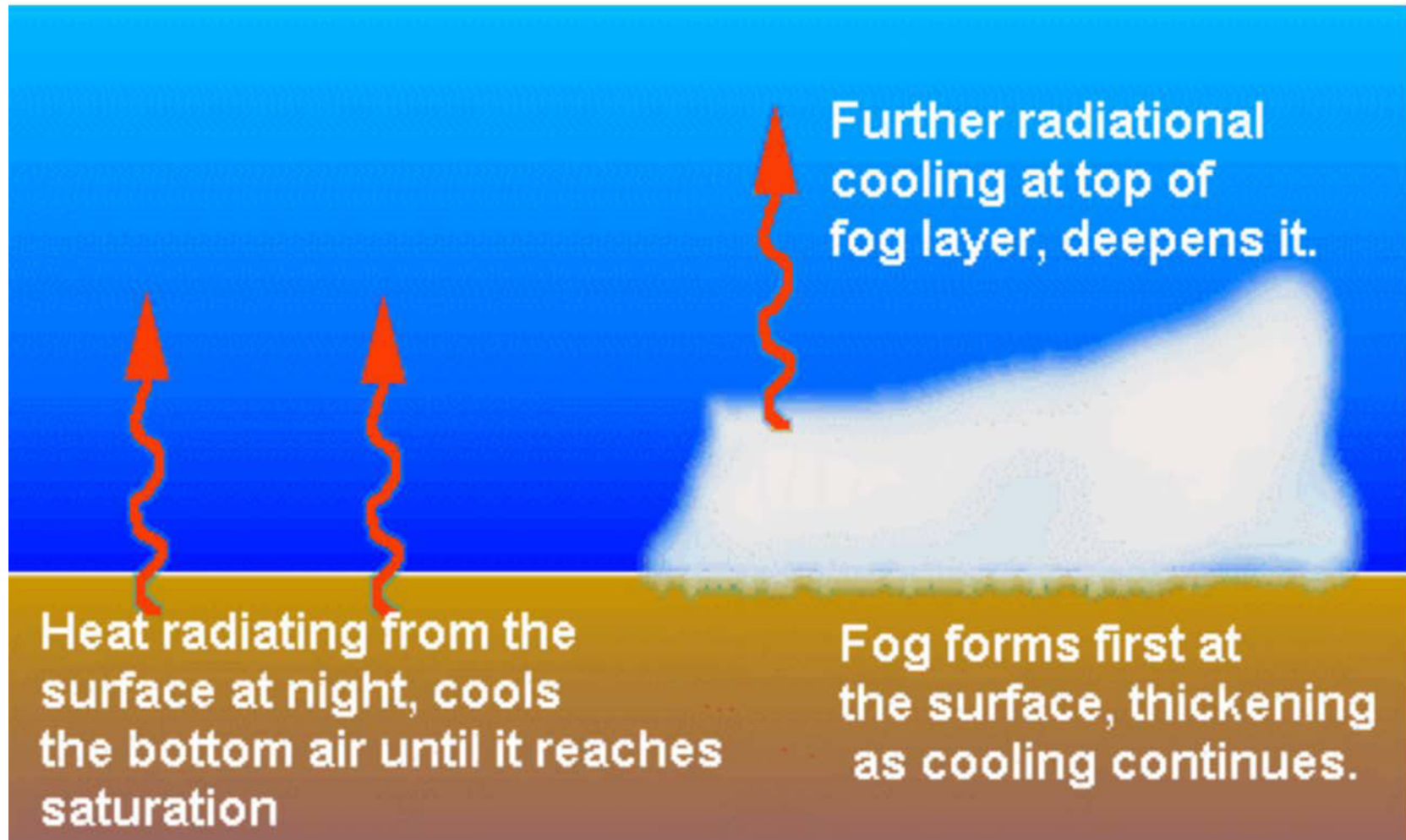

Figure A-1 Radiation Fog

*Note.* From The Fog Rolls In, 2002, *Weather Almanac for September*. Copyright 2002 by The Weather Doctor.  
Retrieved March 2, 2009, from <http://www.islandnet.com/~see/weather/almanac/arc2002/alm02sep.htm>

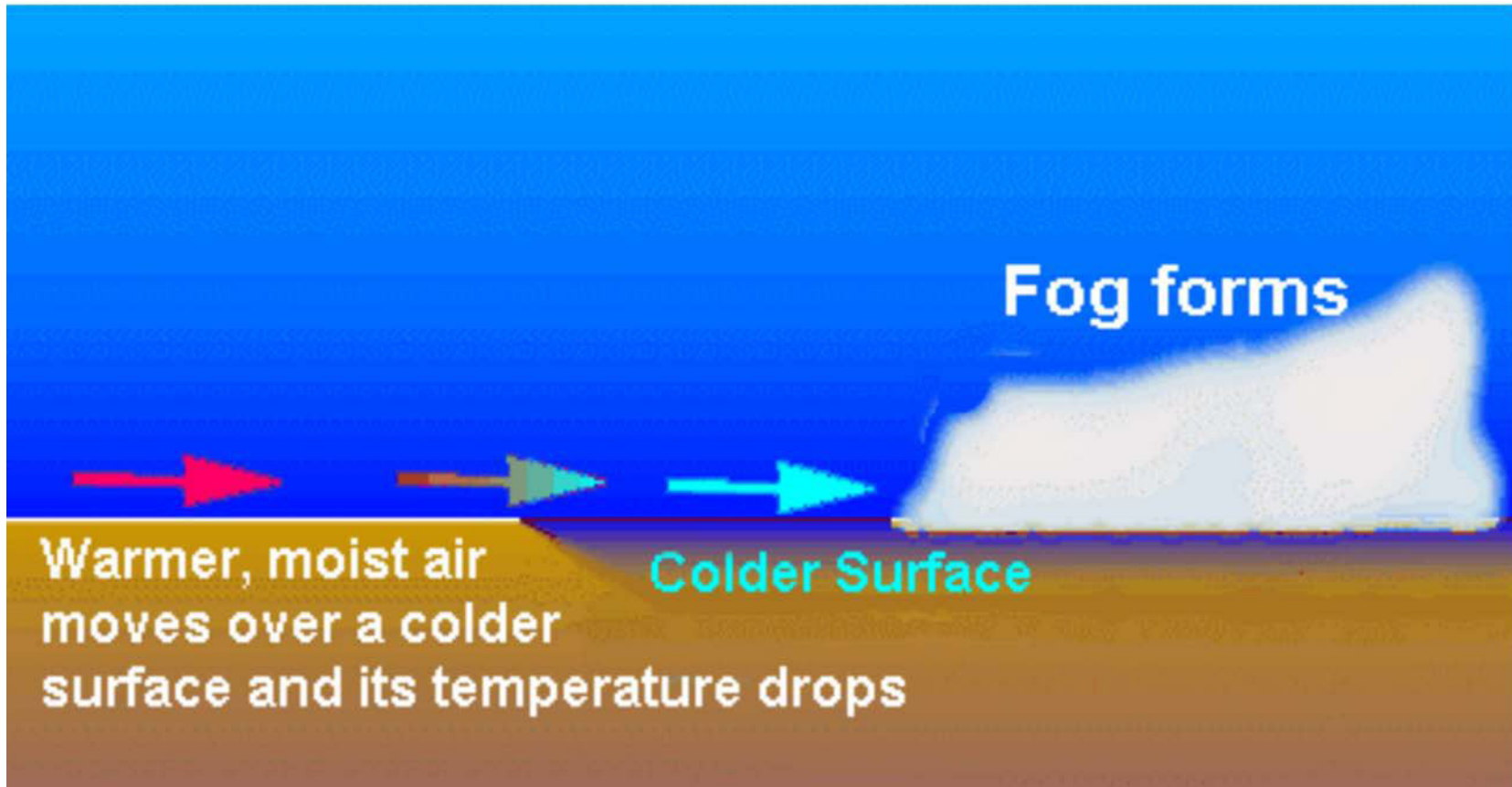

Figure A-2 Advection Fog

*Note.* From The Fog Rolls In, 2002, *Weather Almanac for September*. Copyright 2002 by The Weather Doctor.  
Retrieved March 2, 2009, from <http://www.islandnet.com/~see/weather/almanac/arc2002/alm02sep.htm>

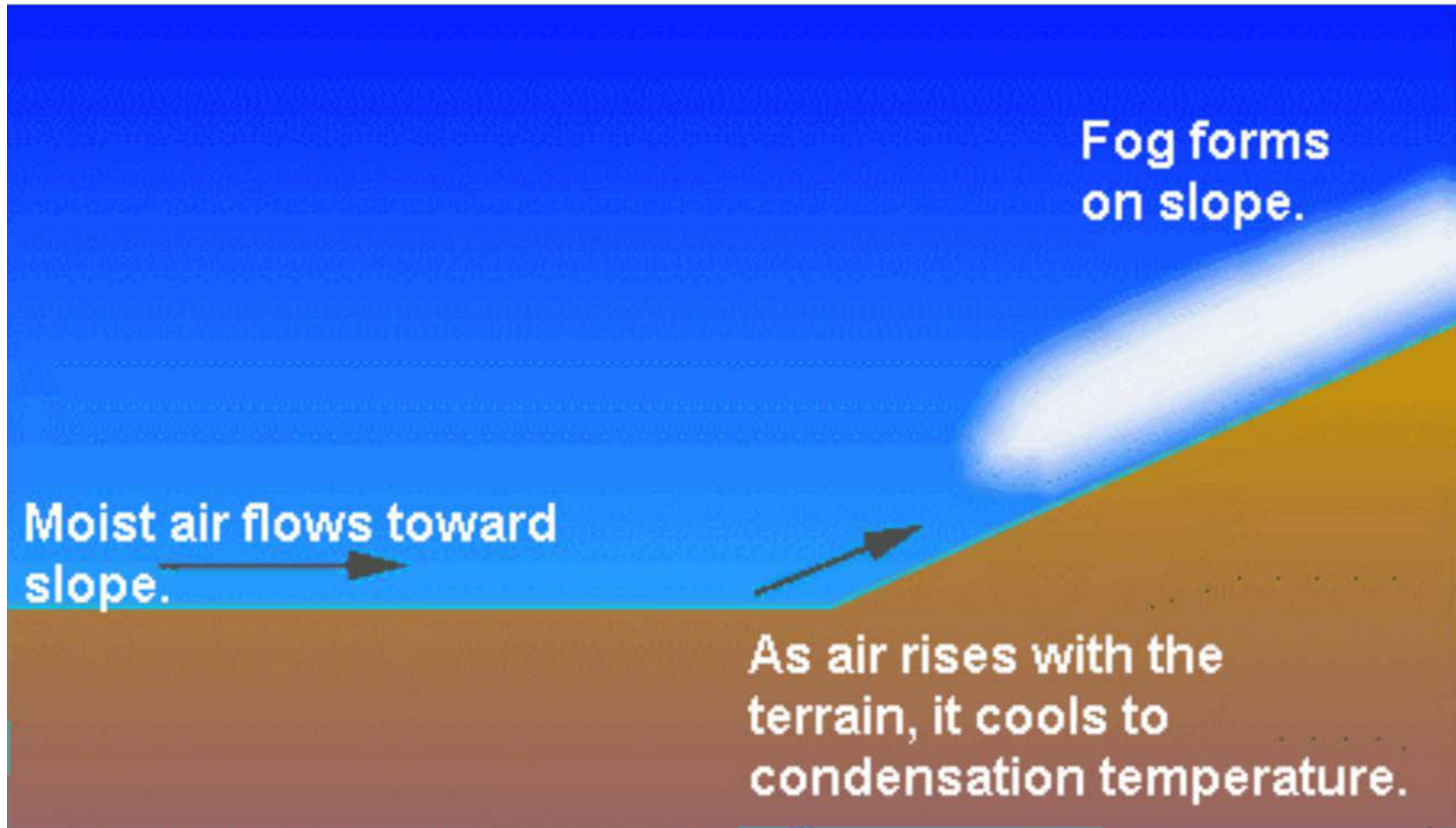

Figure A-3 Upslope Fog

*Note.* From The Fog Rolls In, 2002, *Weather Almanac for September*. Copyright 2002 by The Weather Doctor.  
Retrieved March 2, 2009, from <http://www.islandnet.com/~see/weather/almanac/arc2002/alm02sep.htm>

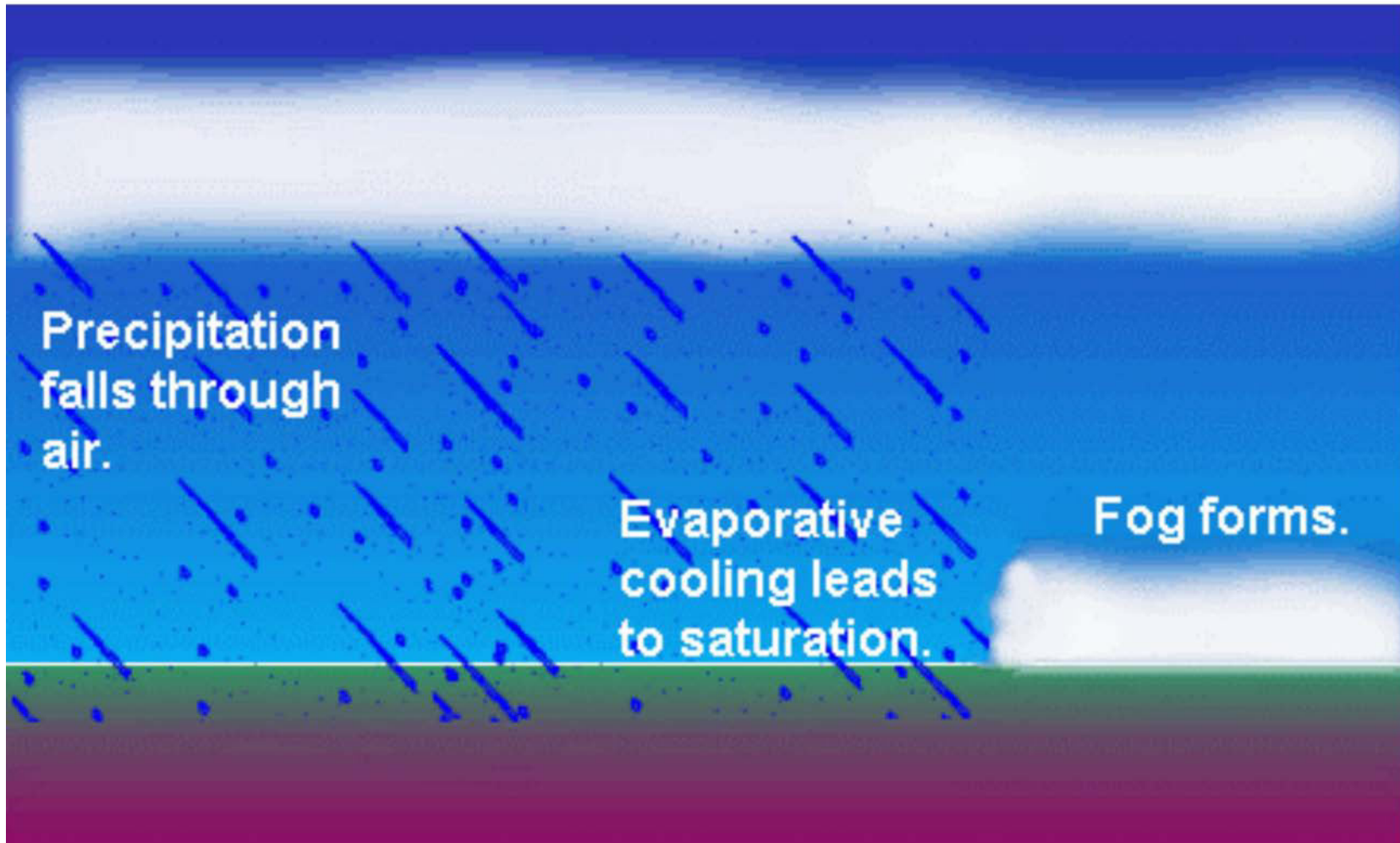

Figure A-4 Precipitation-Induced Fog

Note. From The Fog Rolls In, 2002, *Weather Almanac for September*. Copyright 2002 by The Weather Doctor.  
Retrieved March 2, 2009, from <http://www.islandnet.com/~see/weather/almanac/arc2002/alm02sep.htm>





**ROYAL CANADIAN AIR CADETS  
PROFICIENCY LEVEL FOUR  
INSTRUCTIONAL GUIDE**



**SECTION 4**

**EO C436.02 – DESCRIBE SEVERE WEATHER CONDITIONS**

---

Total Time: 30 min

---

**PREPARATION**

---

**PRE-LESSON INSTRUCTIONS**

Resources needed for the delivery of this lesson are listed in the lesson specification located in A-CR-CCP-804/PG-001, *Proficiency Level Four, Qualification Standard and Plan*, Chapter 4. Specific uses for said resources are identified throughout the instructional guide within the TP for which they are required.

Review the lesson content and become familiar with the material prior to delivering the lesson.

Prepare slides located at Attachment A.

**PRE-LESSON ASSIGNMENT**

Nil.

**APPROACH**

An interactive lecture was chosen for this lesson to introduce the cadet to severe weather conditions and to generate interest.

---

**INTRODUCTION**

---

**REVIEW**

Nil.

**OBJECTIVES**

By the end of this lesson the cadet shall be expected to describe severe weather conditions.

**IMPORTANCE**

It is important for cadets to describe severe weather conditions as knowledge of this material is essential for future aviation training and potential instructional duties at the squadron.

---

**Teaching Point 1**

**Describe thunderstorms.**

Time: 10 min

Method: Interactive Lecture

---

**THUNDERSTORMS**

**Formation**

The requirements for the formation of a thunderstorm are the following:

- unstable air,
- high moisture content, and
- some form of lifting agent.

The intensity of these conditions is the difference between a harmless cumulus cloud and a violent thunderstorm. Such unstable atmospheric conditions may be brought about when air is heated from below (convection), forced to ascend the side of a mountain (orographic lift), or lifted over a frontal surface (frontal lift).



Show slide of Figure A-1.

There are three distinct stages of a thunderstorm:

1. cumulus,
2. mature, and
3. dissipating.

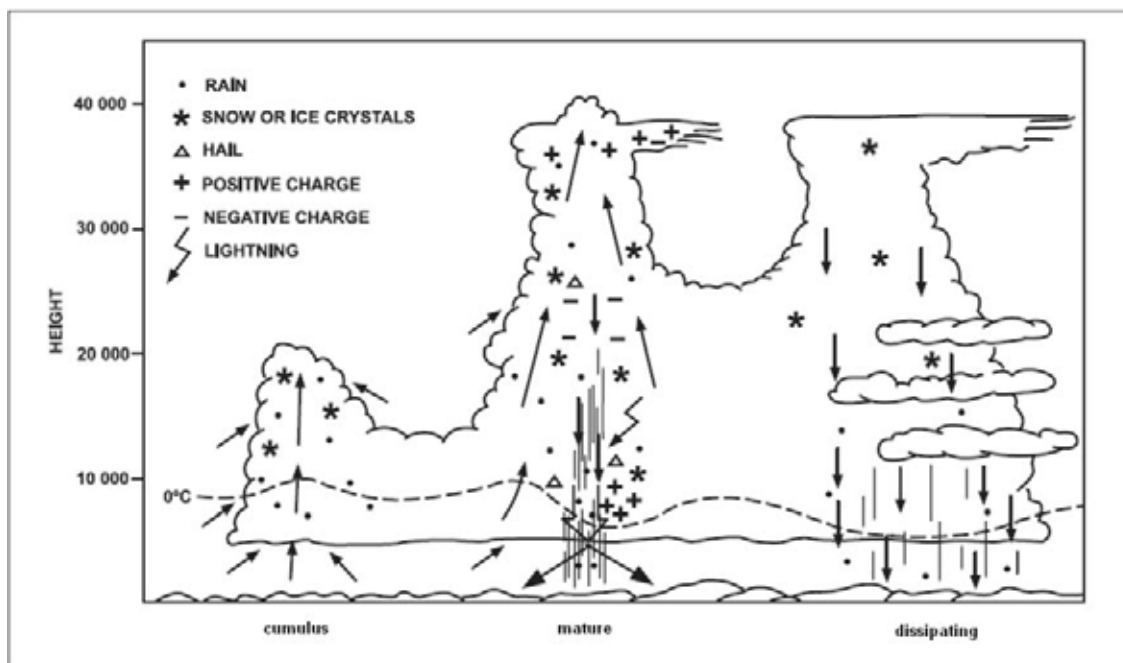

Figure 1 Stages of a Thunderstorm

Note. From *Air Command Weather Manual* (p. 15-2), 2004, Winnipeg, MB: Wing Publishing Office. Copyright 2004 by Her Majesty the Queen in Right of Canada.

Every thunderstorm begins as a cumulus cloud. Strong updrafts, due to the unstable air and lifting agent cause the cloud to build rapidly into a towering cumulus and then cumulonimbus cloud. There is usually no precipitation in this stage as the water droplets and ice crystals are kept suspended in the cloud by the strong updrafts.

In the mature stage, the cumulonimbus cloud may reach heights up to 60 000 feet, with updrafts of 6 000 feet per minute and downdrafts of 2 000 feet per minute. Precipitation, violent turbulence, and thunder and lightning are all associated with thunderstorms in their mature stage.

The precipitation tends to cool the lower region of the cloud causing the thunderstorm cell to dissipate. The downdrafts spread throughout the whole cell except for a small portion at the top where updrafts still occur. The rainfall gradually ceases and the top of the cell spreads out into an anvil shape.

### Dangers



Show slide of Figure A-2.

The dangers of flying in or close to a thunderstorm are:

- severe turbulence,
- lightning,
- hail,
- icing,

- unreliable altimeter readings due to rapid changes in pressure,
- strong wind gusts, and
- heavy rain.

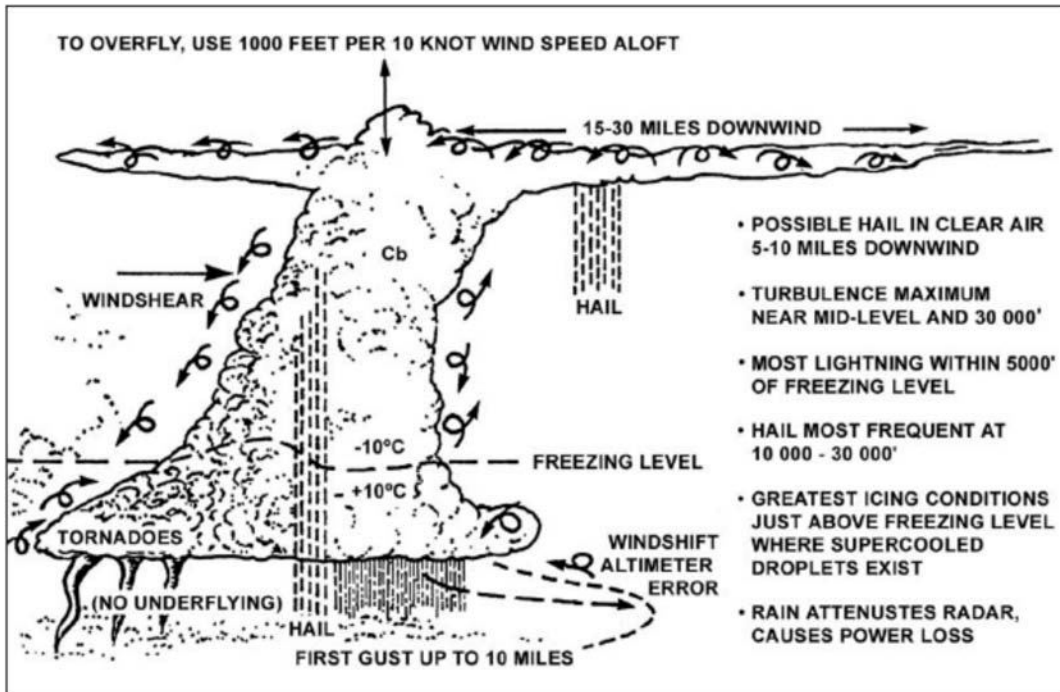

Figure 2 Thunderstorm Dangers

Note. From *Air Command Weather Manual* (p. 15-2), 2004, Winnipeg, MB: Wing Publishing Office. Copyright 2004 by Her Majesty the Queen in Right of Canada.

### Avoidance

Stay at least five miles away from a thunderstorm. When flying around a thunderstorm, fly to the right side of it as the wind is circulating counter-clockwise around the low pressure area. Never fly through a thunderstorm in a light aircraft.

---

### CONFIRMATION OF TEACHING POINT 1

#### QUESTIONS:

- Q1. What are the requirements for the formation of a thunderstorm?
- Q2. In which stage of a thunderstorm will the top of the cumulonimbus cloud take on an anvil shape?
- Q3. What are three of the dangers associated with thunderstorms?

#### ANTICIPATED ANSWERS:

- A1. Unstable air, high moisture content, and some form of lifting agent.
- A2. The dissipating stage.



A3. Cadets may give any three of the following answers:

- severe turbulence,
- lightning,
- hail,
- icing,
- unreliable altimeter readings due to rapid changes in pressure,
- strong wind gusts, and
- heavy rain.

---

### Teaching Point 2

**Describe icing.**

Time: 5 min

Method: Interactive Lecture

---

### ICING

When an airplane flies at an altitude where the outside air temperature is at or below freezing and strikes a supercooled water droplet, the droplet will freeze and adhere to the airplane. This can occur in cloud, freezing rain, or freezing drizzle. Icing can also occur in clear air through sublimation.

#### Types of Icing

There are three main types of icing:

- clear ice,
- rime ice, and
- frost.



Show slide of Figure A-3.

Clear ice is a heavy coating of glassy ice which forms when flying in dense cloud or freezing rain. It forms when only a small part of the supercooled water droplet freezes on impact, with the rest of the droplet spreading out and freezing slowly. Clear ice is the most dangerous form of icing because of the following:

- loss of lift due to the altered camber of the wing,
- increase in drag due to the enlarged profile area of the wings,
- increase in weight due to the large mass of ice, and
- the vibration caused by the unequal loading on the wings and propeller blades.

Rime ice is an opaque (milky white) deposit of ice. Rime ice forms when the aircraft skin is at a temperature below zero degrees Celsius, causing the water droplet to freeze completely on contact. Although rime ice is light, it is dangerous due to the aerodynamic alteration of the wing camber and the interference it causes with the carburetor and pitot static system.

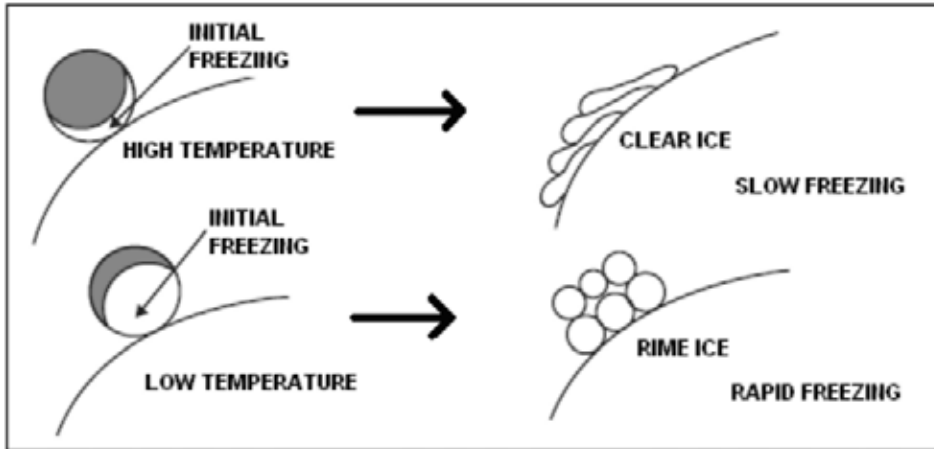

Figure 3 Clear Ice and Rime Ice

*Note.* From *Air Command Weather Manual* (p. 9-4), 2004, Winnipeg, MB: Wing Publishing Office. Copyright 2004 by Her Majesty the Queen in Right of Canada.

Frost is a white semi-crystalline form of icing which forms in clear air by the process of sublimation. It generally forms on two occasions:

- when a cold aircraft enters warmer and damper air during a steep descent; and
- when an aircraft parked outside on a clear cold night cools by radiation to a temperature below that of the surrounding air.

Frost should be removed before takeoff as it will reduce lift and increase the stall speed of the aircraft.



Show slide of Figure A-4.

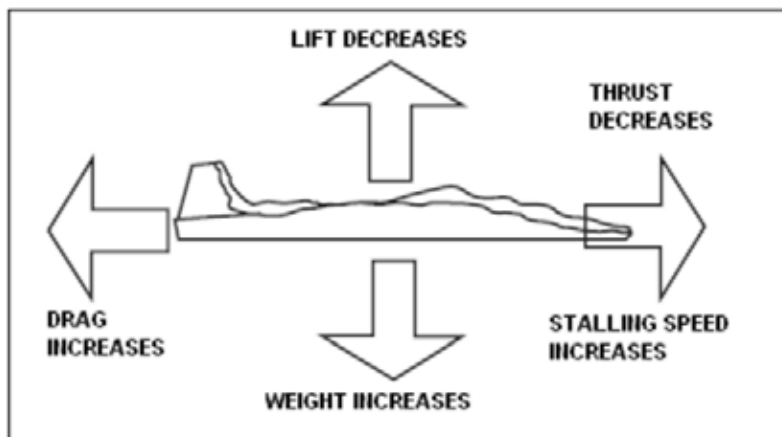

Figure 4 Effects of Icing

*Note.* From *Air Command Weather Manual* (p. 9-1), 2004, Winnipeg, MB: Wing Publishing Office. Copyright 2004 by Her Majesty the Queen in Right of Canada.

## Protection From Icing

Many modern airplanes are fitted with various systems designed to prevent ice from forming or to remove ice after it has formed. Three of these systems are:

- fluids,
- rubber boots, and
- heating devices.

Fluids with a low freezing point are released over the blades of the propellers and the surfaces of the wings to prevent icing.



Show slide of Figure A-5.

Rubber boots are membranes of rubber attached to the leading edges that can pulsate in such a way that ice is cracked and broken off after it has formed.

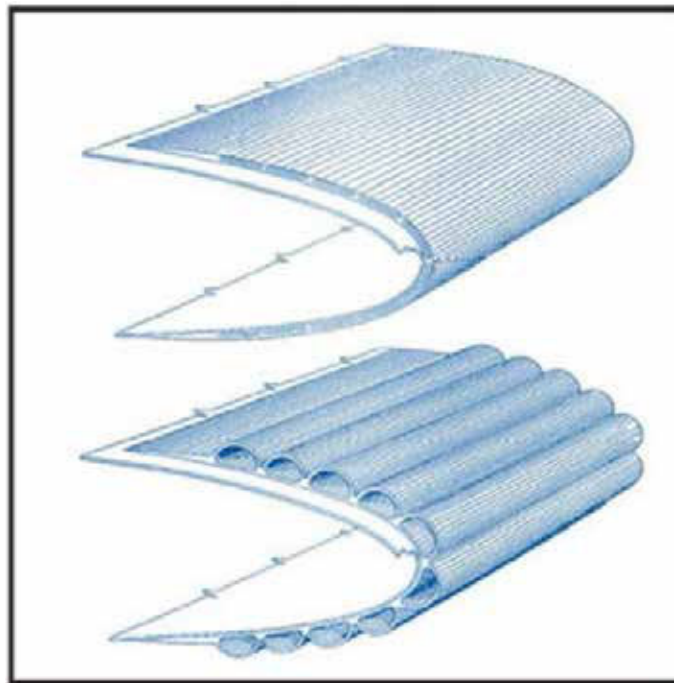

Figure 5 Rubber Boots

*Note.* From "Icing Conditions in Flight", *Pilot Friend*. Retrieved October 22, 2008, from [http://www.pilotfriend.com/safe/safety/icing\\_conditions.htm](http://www.pilotfriend.com/safe/safety/icing_conditions.htm)

Heating vulnerable areas with hot air from the engine or special heaters prevents the buildup of ice.

---

## CONFIRMATION OF TEACHING POINT 2

### QUESTIONS:

- Q1. How can a pilot tell the difference between clear ice and rime ice?
- Q2. How does frost form?
- Q3. What are three methods of protection from icing?

### ANTICIPATED ANSWERS:

- A1. Clear ice is glassy while rime ice is opaque.
- A2. Frost forms through sublimation.
- A3. Fluids, rubber boots, and heating devices.

---

## Teaching Point 3

**Describe types of turbulence.**

Time: 10 min

Method: Interactive Lecture

---

## TYPES OF TURBULENCE

Turbulence is an irregular motion of the air resulting from eddies and vertical currents. It is one of the most unpredictable of all the weather phenomena.

There are four types of turbulence:

- mechanical turbulence,
- thermal turbulence,
- frontal turbulence, and
- wind shear.



Show slides of Figures A-6 and A-7.

## Mechanical Turbulence

Mechanical turbulence is caused by friction between the air and the ground. The intensity of mechanical turbulence depends on the strength of the surface wind, the nature of the terrain, and the stability of the air. Strong winds, rough terrain, and very unstable air create greater turbulence. Mountain waves produce some of the most severe mechanical turbulence.

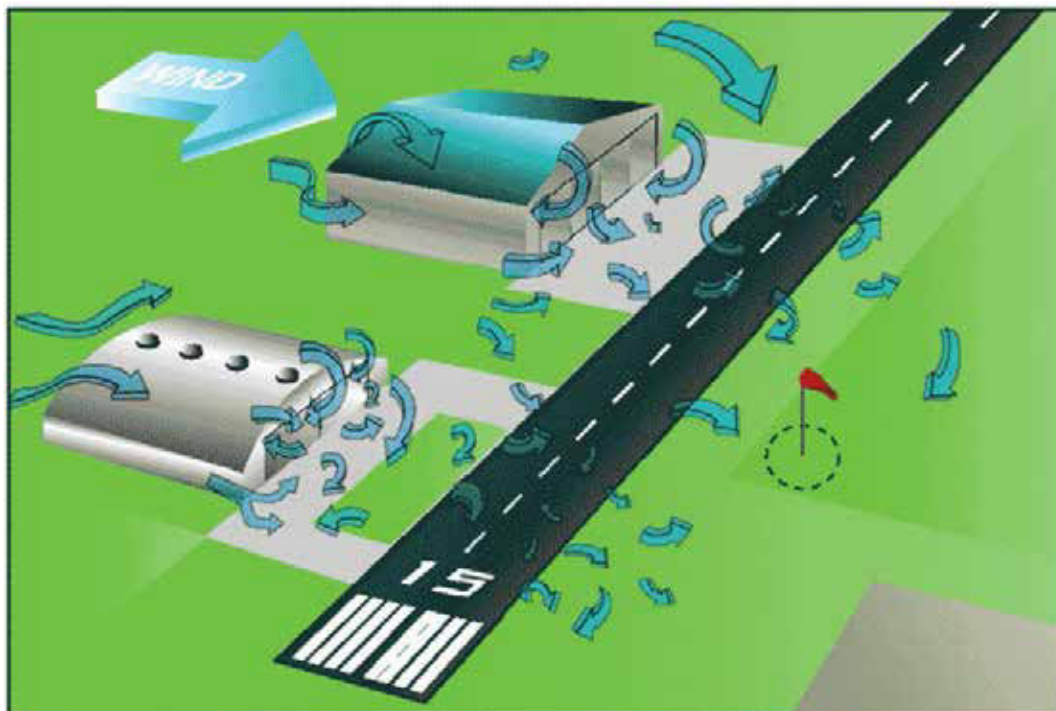

Figure 6 Mechanical Turbulence

*Note.* From "Aviation Weather", *Free Online Private Pilot Ground School*. Retrieved October 22, 2008, from <http://www.free-online-private-pilot-ground-school.com/Aviation-Weather-Principles.html>

### Thermal Turbulence

Thermal turbulence is caused by the uneven heating of the ground. Certain surfaces, such as plowed fields and pavement, are heated more rapidly than others, such as grass-covered fields and water. This causes isolated convective currents that are responsible for bumpy conditions as an airplane flies in and out of them. These convective currents can have a pronounced effect on the flight path of an airplane approaching a landing area, causing it to either overshoot or undershoot.



Rising convective currents are commonly referred to as "thermals" or "lift". Glider pilots use their knowledge of the terrain to find thermals and soar for extended periods of time. They also learn to recognize and avoid sinking convective currents (commonly known as "sink").

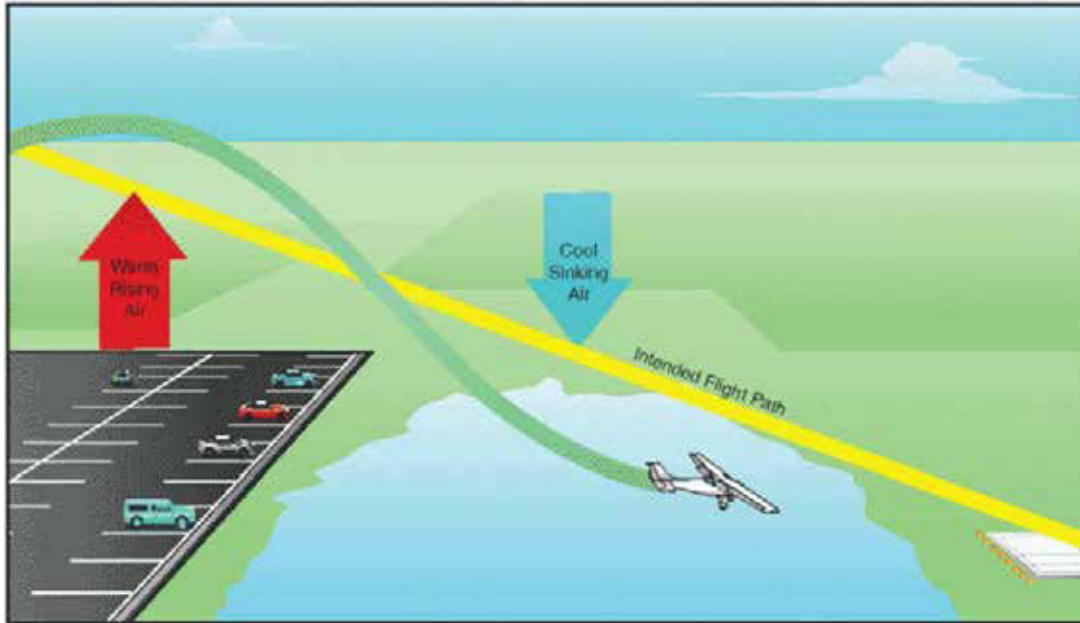

Figure 7 Thermal Turbulence

*Note.* From "Aviation Weather", *Free Online Private Pilot Ground School*. Retrieved October 22, 2008, from <http://www.free-online-private-pilot-ground-school.com/Aviation-Weather-Principles.html>

### Frontal Turbulence

Frontal turbulence is caused by the lifting of warm air by the sloping frontal surface and the friction between the two opposing air masses. This turbulence is strongest in cold fronts, especially when the warm air is moist and unstable.

### Wind Shear

Wind shear is caused when there are significant changes in wind speed and direction with height.

---

## CONFIRMATION OF TEACHING POINT 3

### QUESTIONS:

- Q1. What causes mechanical turbulence?
- Q2. Name two examples of terrain that heat more rapidly than water.
- Q3. In which type of front is turbulence more pronounced?

### ANTICIPATED ANSWERS:

- A1. Mechanical turbulence is caused by friction between the air and the ground.
- A2. A plowed field and pavement.
- A3. Cold front.

---

**END OF LESSON CONFIRMATION****QUESTIONS:**

- Q1. What are the three stages of a thunderstorm?
- Q2. What are the three main types of icing?
- Q3. What are the four types of turbulence?

**ANSWERS:**

- A1. Cumulus, mature, and dissipating.
- A2. Clear ice, rime ice, and frost.
- A3. Mechanical turbulence, thermal turbulence, frontal turbulence, and wind shear.

---

**CONCLUSION**

---

**HOMEWORK / READING / PRACTICE**

Nil.

**METHOD OF EVALUATION**

Nil.

**CLOSING STATEMENT**

Severe weather conditions can adversely affect a flight and ruin a pilot's day. Knowing how to recognize and deal with these conditions is essential for future aviation training.

**INSTRUCTOR NOTES / REMARKS**

Cadets who are qualified Advanced Aviation may assist with this instruction.

---

**REFERENCES**

---

C3-116 ISBN 0-9680390-5-7 MacDonald, A. F., & Peppler, I. L. (2000). *From the ground up: Millennium edition*. Ottawa, ON: Aviation Publishers Co. Limited

THIS PAGE INTENTIONALLY LEFT BLANK



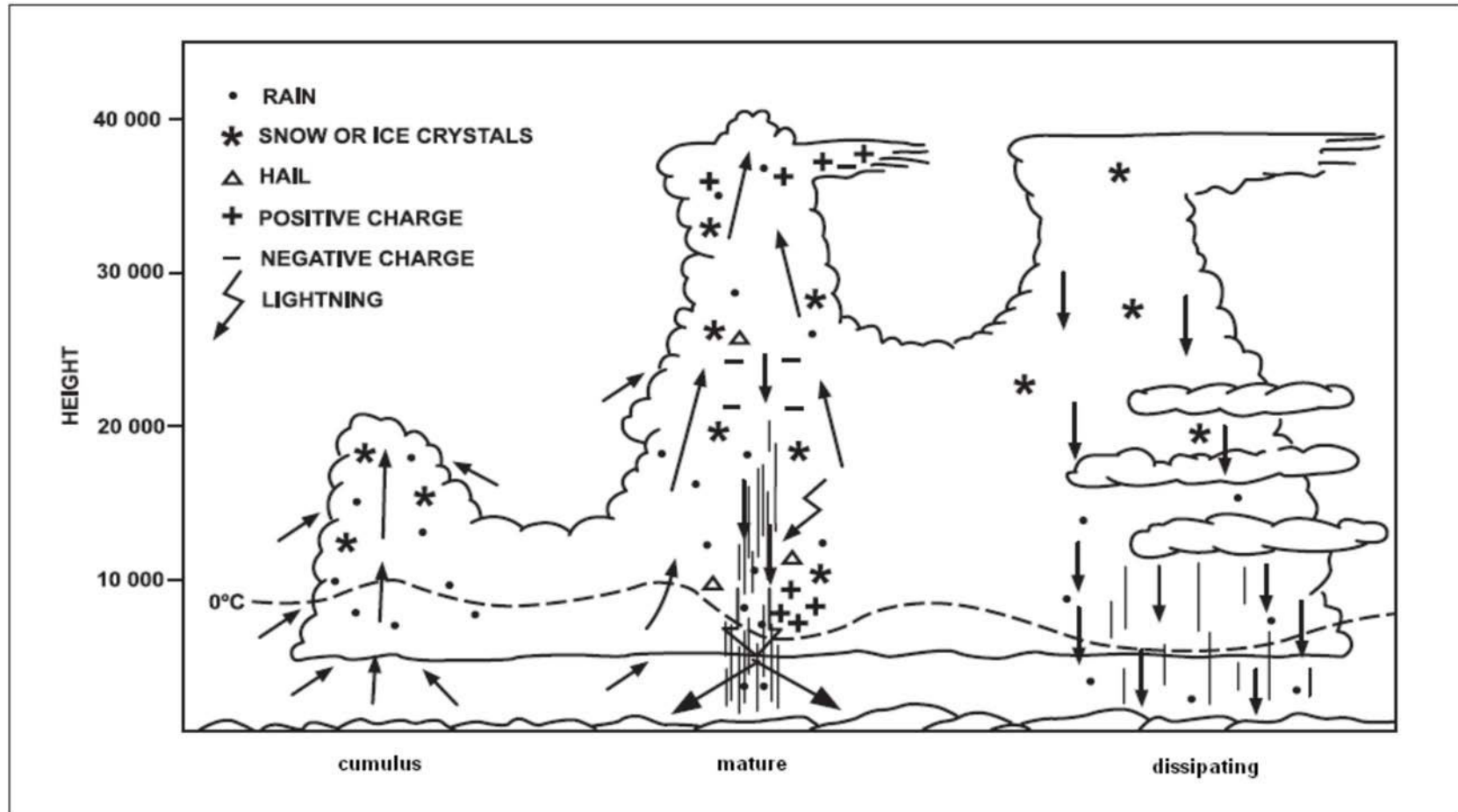

Figure A-1 Stages of a Thunderstorm

Note. From *Air Command Weather Manual* (p. 15-2), 2004, Winnipeg, MB: Wing Publishing Office. Copyright 2004 by Her Majesty the Queen in Right of Canada.

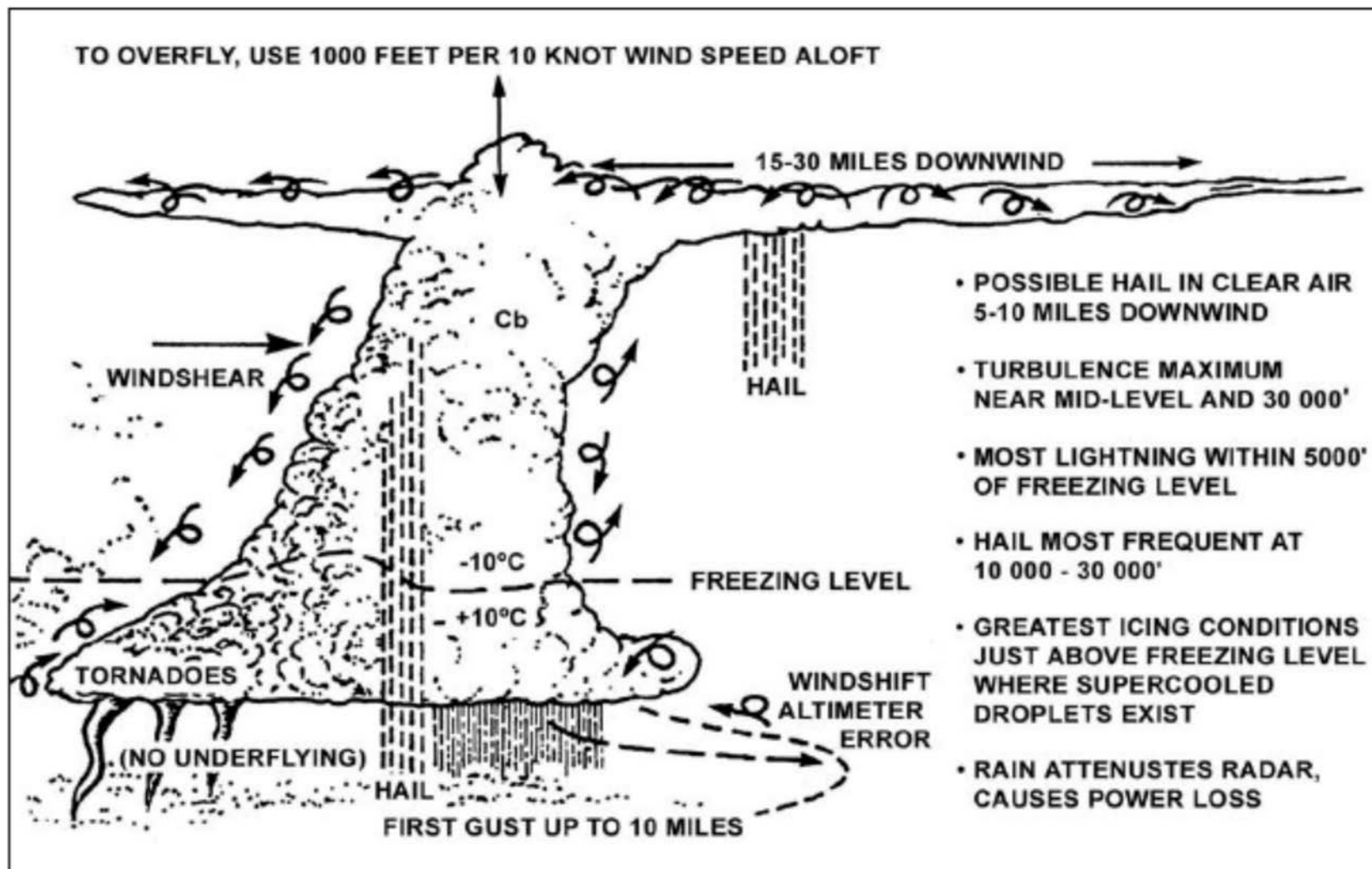

Figure A-2 Thunderstorm Dangers

Note. From *Air Command Weather Manual* (p. 15-2), 2004, Winnipeg, MB: Wing Publishing Office. Copyright 2004 by Her Majesty the Queen in Right of Canada.

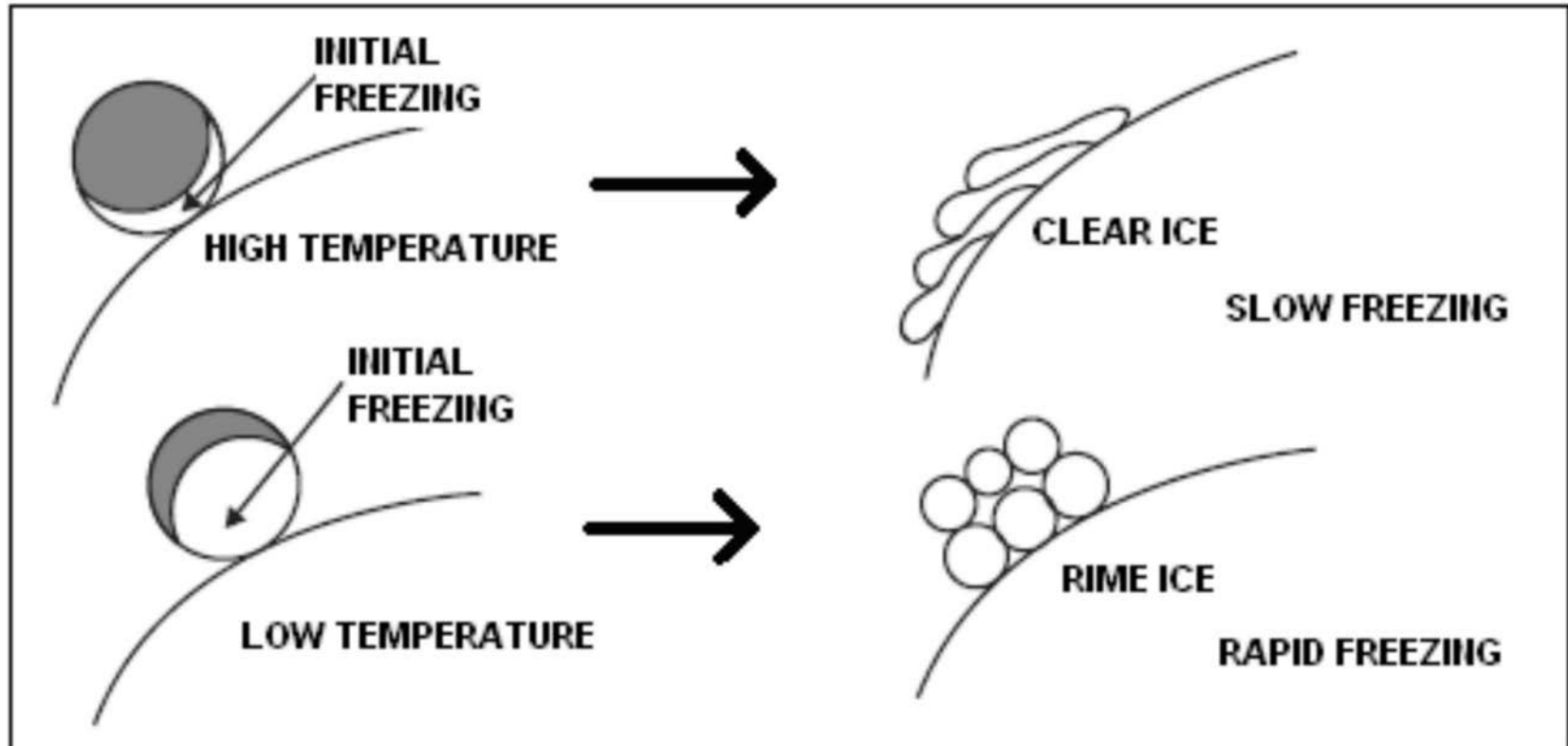

Figure A-3 Clear Ice and Rime Ice

Note. From *Air Command Weather Manual* (p. 9-4), 2004, Winnipeg, MB: Wing Publishing Office. Copyright 2004 by Her Majesty the Queen in Right of Canada.

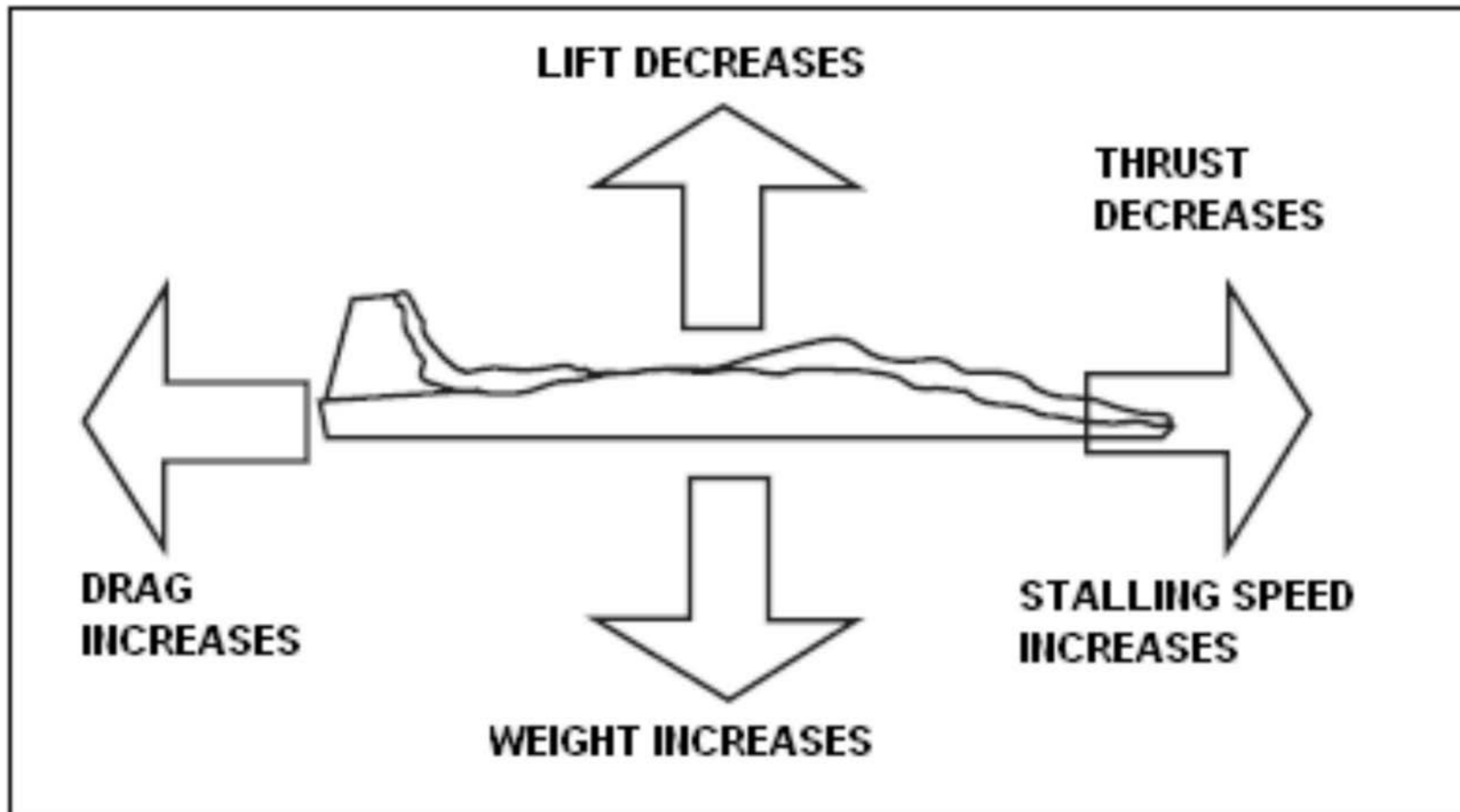

Figure A-4 Effects of Icing

Note. From *Air Command Weather Manual* (p. 9-1), 2004, Winnipeg, MB: Wing Publishing Office. Copyright 2004 by Her Majesty the Queen in Right of Canada.

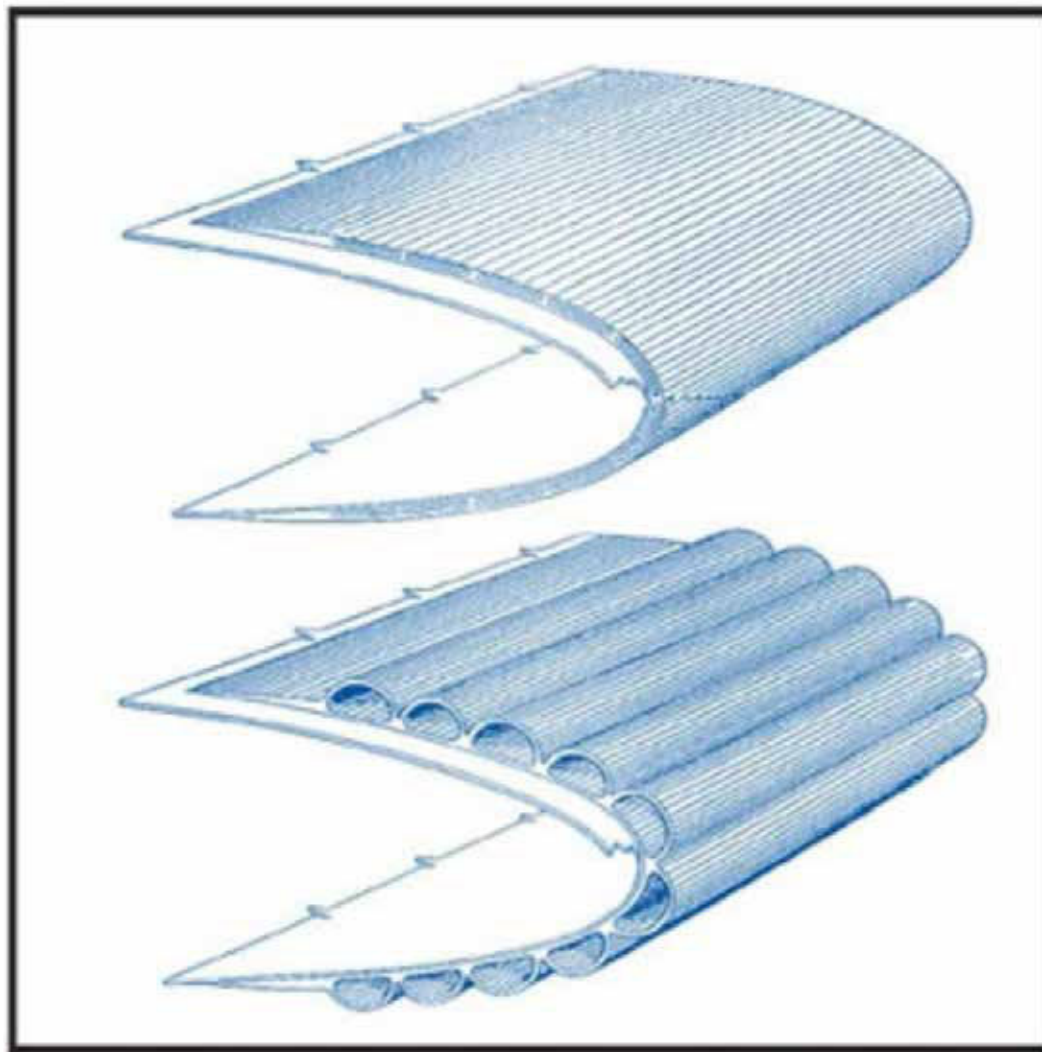

Figure A-5 Rubber Boots

Note. From "Icing Conditions in Flight", *Pilot Friend*. Retrieved October 22, 2008, from [http://www.pilotfriend.com/safe/safety/icing\\_conditions.htm](http://www.pilotfriend.com/safe/safety/icing_conditions.htm)

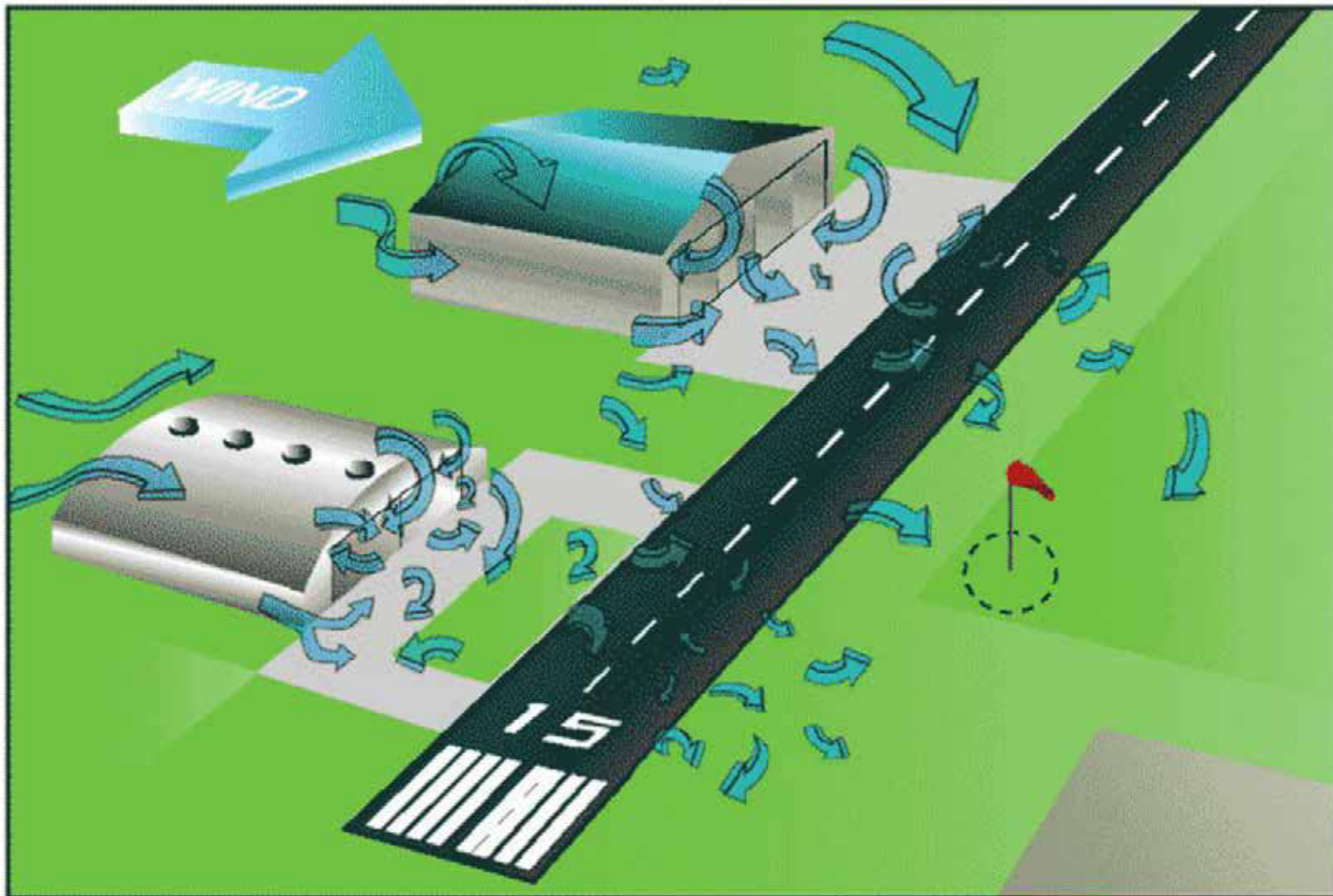

Figure A-6 Mechanical Turbulence

*Note.* From "Aviation Weather", *Free Online Private Pilot Ground School*. Retrieved October 22, 2008, from <http://www.free-online-private-pilot-ground-school.com/Aviation-Weather-Principles.html>



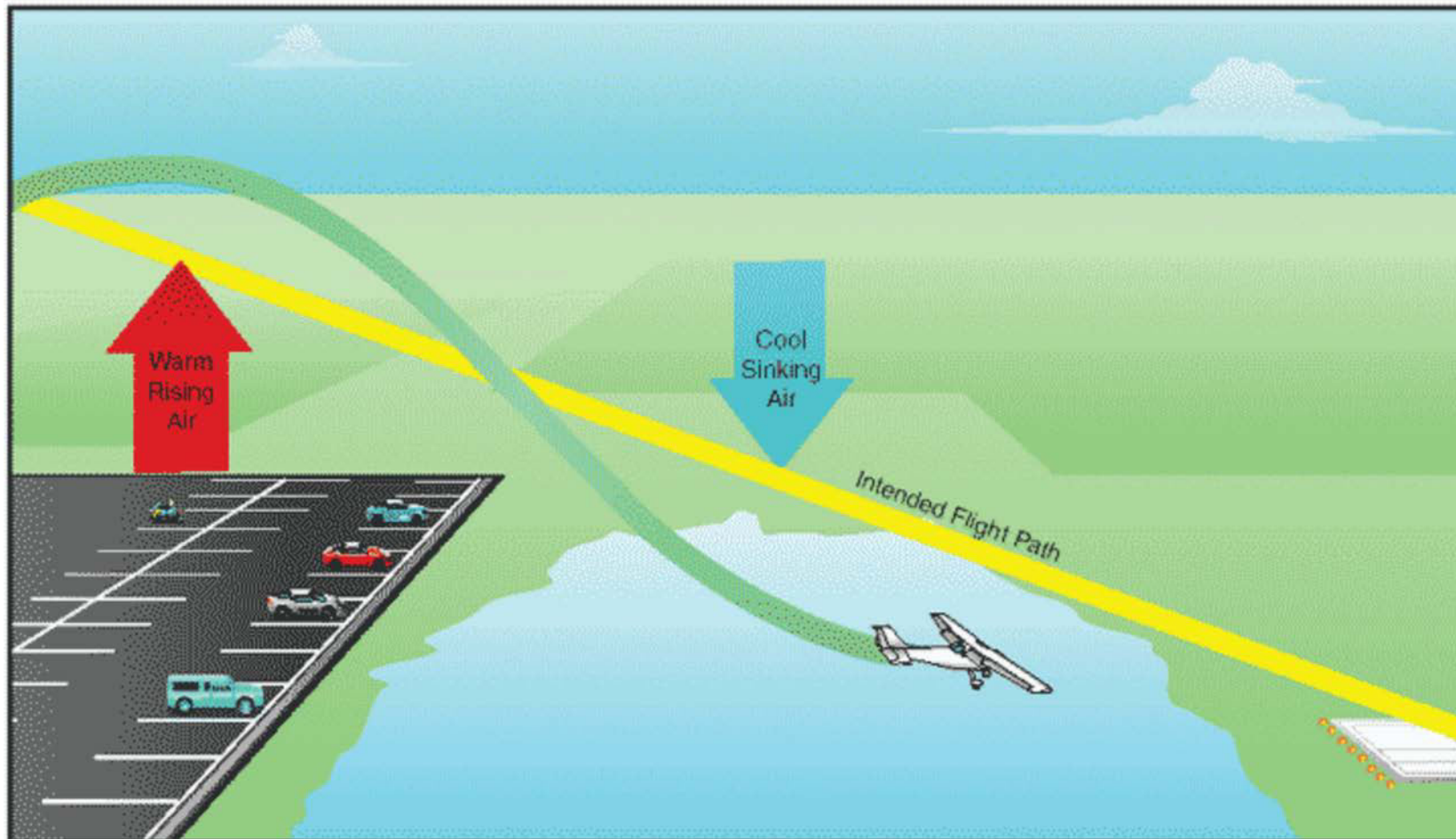

Figure A-7 Thermal Turbulence

*Note.* From "Aviation Weather", *Free Online Private Pilot Ground School*. Retrieved October 22, 2008, from <http://www.free-online-private-pilot-ground-school.com/Aviation-Weather-Principles.html>

THIS PAGE INTENTIONALLY LEFT BLANK





**ROYAL CANADIAN AIR CADETS  
PROFICIENCY LEVEL FOUR  
INSTRUCTIONAL GUIDE**



**SECTION 5**

**EO C436.03 – ANALYZE WEATHER INFORMATION**

Total Time:

90 min

**PREPARATION**

**PRE-LESSON INSTRUCTIONS**

Resources needed for the delivery of this lesson are listed in the lesson specification located in A-CR-CCP-804/PG-001, *Proficiency Level Four Qualification Standard and Plan*, Chapter 4. Specific uses for said resources are identified throughout the instructional guide within the TP for which they are required.

Review the lesson content and become familiar with the material prior to delivering the lesson.

Prepare the slides located at Attachments A, C–G, I and J.

Photocopy the handouts located at Attachments B and H.

Make handouts of recent METARs, TAFs, FDs and GFAs in standard format from the NAV CANADA aviation weather website for each cadet.

Make a copy in plain language of the same METARs, TAFs, FDs and GFAs handouts from the NAV CANADA aviation weather website being given to each cadet.

**PRE-LESSON ASSIGNMENT**

Nil.

**APPROACH**

An interactive lecture was chosen for TPs 1–7 to introduce weather reports and forecasts, to give the cadets the basic material they need to decode and analyze the information and to generate interest in the subject.

An in-class activity was chosen for TP 8 as it is an interactive way for the cadets to practice analyzing weather information under supervision.

**INTRODUCTION**

**REVIEW**

Nil.

**OBJECTIVES**

By the end of this lesson the cadet shall have analyzed weather information.

**IMPORTANCE**

It is important for cadets to analyze weather information as this skill is used by cadets to analyze weather when preparing for day-to-day activities and to fly. Being able to analyze weather information provides knowledge for potential instructional duties and is part of the fundamentals that cadets pursuing future aviation training will require.

---

**Teaching Point 1****Describe a METAR.**

Time: 5 min

Method: Interactive Lecture

---

**METARs**



Show the cadets the slide of Attachment A.

**Definition**

METAR is the name given to the international meteorological code used in aviation routine weather reports. These reports describe the existing weather conditions at a specific time and location. In other words, the METAR is a snapshot of the current weather; it is not a forecast.

**Frequency of Reports**

METARS are normally issued every hour, on the hour as weather does not normally change much in this brief period of time. METARs are only valid at the time that they are issued, not for the hour between reports.

**Special Weather Reports (SPECI)**

There are times when the weather changes drastically in a short period of time. When this happens a SPECI is issued. SPECIs use the same code as a METAR, but start with SPECI.

**Where METARs are Available**

METARs can be found at several locations. The three most common locations are:

- NAV CANADA's aviation weather website,
- a Flight Services Station (FSS), and
- a Flight Information Centre (FIC) (normally accessed by phone).

---

**CONFIRMATION OF TEACHING POINT 1****QUESTIONS:**

- Q1. What does a METAR describe?
- Q2. How often are METARs normally issued?
- Q3. When is a SPECI issued?

**ANTICIPATED ANSWERS:**

- A1. A METAR describes the existing weather conditions at a specific time and location.
- A2. METARS are normally issued every hour, on the hour.
- A3. A SPECI is used when the weather changes drastically in a short period of time.

---

**Teaching Point 2****Familiarize the cadets with METAR terminology.**

Time: 15 min

Method: Interactive Lecture

---

**TERMINOLOGY USED IN METARs**

Indicate on the slide of Attachment A each of the following groupings as they are covered.

METAR is a code used in aviation weather reporting. This code is based on the World Meteorological Organization's (WMO) standards and conventions. A METAR is organized into sections with each section always in the same order.

**Report Type**

The report name is in the first line of the text. The name will show as either METAR or SPECI.

**Location Indicator**

Each weather reporting station in Canada is assigned a four-letter identifier, starting with the letter C. The second letter indicates the type of station and the last two letters identify the specific reporting station.

For example, CYOW is the reporting station at Ottawa / MacDonald-Cartier International Airport. The C means the station is Canadian, the Y means the station is co-located with an airport, and OW is the airport identifier.

**Date and Time of Observation**

The date and time of the observation are given as a six-digit grouping, based on Coordinated Universal Time (UTC / ZULU / Z). The first two digits signify the day of the current month, while the last four digits signify the time of the day. The official time of the observation is given for all METAR reports that do not deviate more than 10 minutes from the top of the hour. SPECIs will have the time reported to the exact minute.

For example, a METAR will show as 091000Z which means that the observation was taken on the ninth day of the month at 1000 hours UTC (or within 10 minutes of that hour).

For example, a SPECI will show as 091036Z, which means that a significant change in weather was observed on the ninth day of the month at 1036 hours UTC.

**Report Modifier**

This field may contain two possible codes: AUTO or CC\* (where \* is a letter from A–Z which represents corrections). AUTO indicates that the report is primarily based on observations from an automated weather observation station (AWOS). CC\* is used to indicate corrected reports, where the first correction is CCA, the second is CCB, and so on. Both AUTO and CC\* may be found in the same report.

**Wind**

This group reports the two-minute average wind direction and speed. Direction is always three digits, given in degrees true but rounded off to the nearest 10 degrees. Speed is normally two digits, and is given in knots (nautical miles per hour or kt). A reading of 0000KT indicates calm winds.

For example, 35016KT means winds are from 350 degrees true (rounded off) at 16 knots.

If gust conditions exist, the direction and speed will be followed by a G and the maximum gust strength. A gust must be five knots stronger than the 10-minute average wind speed.

For example, 35016G25KT means winds are from 350 degrees true at 16 knots gusting to 25 knots.

### Prevailing Visibility

Prevailing visibility is the average visibility at the reporting station. The prevailing visibility is reported in statute miles (SM) or fractions of a statute mile.

For example, 3SM means the prevailing visibility is 3 statute miles.

### Runway Visual Range

This is only included if the prevailing visibility is less than 1 SM, or the runway visual range is less than 6 000 feet. This group will start with an R, then the runway number (eg, 06) and position (eg, L for left, R for right, C for centre), followed by the runway visual range in hundreds of feet. This is based on a 10-minute average. The runway visual range trend is indicated if there is a distinct upward or downward trend from the first to the second five-minute part-period. If the runway visual range changes by 300 feet or more it is indicated as /U for an upward trend or /D for a downward trend. No distinct change is indicated as /N. If it is not possible to determine the trend it will be left blank.

For example, R06L/4000FT/D means the runway visual range for runway 06 left is 4 000 feet with a downward trend.

### Present Weather



Distribute the handout of Attachment B to the cadets.

This group indicates the current weather phenomena at the reporting station. This may include precipitation, obscuration, or other phenomena.

Each phenomenon is represented by a code, which may be two to nine characters in length. Each code may include one or both of the following prefixes:

- **Intensity.** (-) indicates light, (+) indicates heavy, and no symbol indicates moderate.
- **Proximity.** Used primarily with precipitation or tornadoes. VC will precede certain phenomena, meaning that they are in the vicinity (5 SM) of the station, but not actually at the station.

For example, VCFZRABLSN+SNVA means in the vicinity of the airport there is freezing rain, blowing snow, heavy snow, and volcanic ash.



The abbreviations used for present weather are a mixture of English and French root words. FZ comes from freezing, while BR comes from brumé (mist), and FU comes from fumée (smoke).

## Sky Conditions

This group reports the sky condition for layers aloft. The group will include how much of the sky is covered, measured in oktas (eighths of the sky) and the height of the clouds in hundreds of feet above ground level (AGL). The sky cover is represented by the following abbreviations:

- **SKC.** Sky clear, no cloud present.
- **FEW.** Few, greater than zero to two-eighths cloud cover.
- **SCT.** Scattered, three-eighths to four-eighths cloud cover.
- **BKN.** Broken, five-eighths to less than eight-eighths cloud cover.
- **OVC.** Overcast, eight-eighths cloud cover.
- **CLR.** Clear, clear below 10 000 feet AGL.

Cloud height is represented by a three-digit number, which when multiplied by one hundred equals the actual height AGL. There will be one entry for every layer of cloud.

For example, SCT025 means scattered cloud at 2 500 feet AGL.

## Temperature and Dewpoint

This group reports the air temperature and dewpoint temperature, rounded to the nearest whole degree Celsius. A negative value will be preceded by an M. A forward slash (/) will separate the two values.

For example, M05/M08 means the temperature is minus five degrees Celsius and the dewpoint is minus eight degrees Celsius.

## Altimeter Setting

This group reports the altimeter setting at the reporting station in inches of mercury. The group starts with an A followed by four digits, which directly relate to the actual value of the altimeter setting. Place a decimal after the second digit in order to read this group.

For example, A3006 means the altimeter setting is 30.06 inches of mercury.

## Recent Weather

This group reports recent weather of operational significance. The group indicator RE follows without a space, by the appropriate abbreviation(s) for weather observed during the period since the last METAR or SPECI, but not observed at the time of observation.

For example, RE+PL means although not observed now, there were heavy ice pellets recently reported.

## Wind Shear

This group reports low level wind shear (within 1 600 feet AGL) along the takeoff or approach path of the designated runway. The two-number runway identifier is used, to which the letters L, C, or R may be appended. If the existence of wind shear applies to all runways, WS ALL RWY is used.

## Remarks

This group will usually include cloud types in each layer as well as opacity, general weather remarks, and sea level pressure measured in hectopascals (hPa). The sea level pressure will always be the last entry in a METAR, prefaced by SLP. Sea level pressure is translated by placing the decimal point between the last two digits and either adding a 9 or a 10 in front of the value given. The goal is to make the number as close to 1 000 as possible.

For example, SLP123 means sea level pressure is 1012.3 hPa.

For example, SLP998 means sea level pressure is 999.8 hPa.



SLP actually represents the station pressure or the theoretical sea level pressure at the reporting station.



The = symbol is used to indicate the end of information.

---

## CONFIRMATION OF TEACHING POINT 2

### QUESTIONS:

- Q1. How are date and time expressed in a METAR?
- Q2. What does the present weather section indicate?
- Q3. What is the last entry of a METAR?

### ANTICIPATED ANSWERS:

- A1. The date and time of the observation are given in a six-digit grouping, based on universal coordinated time (UTC).
- A2. This section indicates the current weather phenomena at the reporting station.
- A3. The sea level pressure will always be the last entry in a METAR.

---

## Teaching Point 3

**Describe a TAF.**

Time: 5 min

Method: Interactive Lecture

## TAFs



Show the cadets the slide of Attachment C.

## Definition

TAF is the name given to the international meteorological code for an aerodrome forecast. These forecasts describe the expected weather conditions that will affect takeoff and landing at the aerodrome.

## Issue and Validity

TAFs are prepared for approximately 180 aerodromes across Canada. They are limited to aerodromes for which METAR and SPECI reports are available. TAFs are generally prepared four times daily with periods of coverage from 12–24 hours. A TAF is valid from the time of issue until it is amended or until the next scheduled TAF is issued.

## Where TAFs are Available

TAFs can be found at several locations. The three most common locations are:

- NAV CANADA's aviation weather website,
- a Flight Services Station (FSS), and
- a Flight Information Centre (FIC) (normally accessed by phone).

---

## CONFIRMATION OF TEACHING POINT 3

### QUESTIONS:

- Q1. What do TAFs describe?
- Q2. How often are TAFs generally prepared?
- Q3. Where can TAFs be found?

### ANTICIPATED ANSWERS:

- A1. The expected weather conditions that will affect takeoff and landing at an aerodrome.
- A2. Four times daily.
- A3. TAFs can be found at:
- NAV CANADA's aviation weather website,
  - an FSS, or
  - an FIC.

---

## Teaching Point 4

**Familiarize the cadets with TAF terminology.**

Time: 15 min

Method: Interactive Lecture

---

## TERMINOLOGY USED IN TAFs



Indicate on the slide of Attachment C each of the following groupings as they are covered.





Much of this information will be a brief review as TAFs are similar to METARs in many ways. The abbreviations of expected weather conditions will follow the same form and order of the METAR, and will have the same meaning.

A TAF is organized into sections with each section always in the same order.

### **Report Type**

The code name TAF is given in the first line of text. It may be followed by “AMD” for amended or corrected forecasts.

### **Location Indicator**

A four-letter International Civil Aviation Organization (ICAO) location indicator is used, as in the METAR.

### **Date and Time of Origin**

As with the METAR format, the day of the month and time (UTC) of origin are included in all forecasts. TAFs are issued approximately 30 minutes before the validity period. Some forecasts have update cycles as frequent as every three hours; however, the next issue time will always be indicated in the remarks group.

### **Period of Validity**

The period of validity for the TAF is indicated by two four-digit date / time groups. The first four-digit group indicates the start date and time of the TAF, and the second four-digit group indicates the end date and time of the TAF. The maximum validity period for a TAF is 30 hours; however, some TAFs have staggered issue times and more frequent update cycles, which will affect their periods of validity.

### **Wind**

The forecasted wind direction and speed are encoded as in a METAR.

### **Low-Level Wind Shear**

This group is used if the forecaster has strong evidence to expect significant, non-convective wind shear that could adversely affect aircraft operation within 1 500 feet AGL over the aerodrome. The coded grouping begins with the letters WS followed by a three-digit grouping indicating the height in hundreds of feet AGL of the shear zone. A slash followed by a five-digit group indicates the wind speed and direction at that height.

For example, WS 015/20015KT means wind shear is forecast at 1 500 feet AGL over the aerodrome. The wind will be from 200 degrees true at 15 knots.

### **Prevailing Visibility**

The prevailing visibility is encoded as in a METAR, except that visibility greater than six statute miles will be indicated by the code P6SM.

For example, 3/4SM means the visibility is forecast to be 3/4 statute mile.

## Significant Weather



Refer the cadets to the handout of Attachment B.

Significant weather is encoded with the same codes as present weather in METARs. Intensity and proximity qualifiers, descriptors, precipitation, and obscuration are included as required.

For example, -RA BR means light rain and mist.

### Sky Condition

Sky condition is encoded as in a METAR. Possible codes for sky cover amounts are SKC, FEW, SCT, BKN, OVC, CLR, and VV. A vertical visibility (VV) is reported in hundreds of feet when the sky is obscured. Forecast cloud type is not identified except in the case of cumulonimbus layers.

For example, BKN040CB means broken cumulonimbus cloud at 4 000 feet.

### Change Groups

There are four change groups:

- FM (from),
- BECMG (becoming),
- TEMPO (temporarily), and
- PROB (probability).

**FM.** Indicates the weather is forecast to change permanently and rapidly. All forecast conditions given before this group are superseded by the conditions indicated after the group. In other words, a complete forecast will follow and all elements must be indicated, including those for which no change is forecast. The time group represents hours and minutes in UTC.

For example, FM280945 means from the 28<sup>th</sup> day of the month at 0945Z.

**BECMG.** Used when a permanent change in a few weather elements is forecast to occur gradually, with conditions evolving over a period of time (normally one to two hours, but not more than four hours). Normally only those elements for which a change is forecast to occur will follow BECMG. Any forecast weather element not indicated as part of the BECMG group remains the same as the period prior to the change.

The start and stop time of the change period is indicated by two four-digit date / time groups following BECMG. The first two digits of each group indicate the date, while the last two digits of each group indicate the time in whole UTC hours.

For example, BECMG 2808/2809 OVC030 means a change towards overcast sky conditions at 3 000 ft AGL occurring gradually between 0800Z and 0900Z on the 28<sup>th</sup> day of the month.

**TEMPO.** Used when a temporary fluctuation in some or all of the weather elements is forecast to occur during a specified period. When an element is not indicated after TEMPO, it is the same as the period prior to the change. The time period is indicated the same as with BECMG.

For example, TEMPO 2812/2815 1SM RA BR means temporarily between 1200Z and 1500Z on the 28<sup>th</sup> day of the month, visibility is forecast to be one statute mile with rain and mist.



If a significant change in weather or visibility is forecast, all weather groups are indicated following BECMG or TEMPO, including those that are unchanged. When the ending of significant weather is forecast, the abbreviation NSW (no significant weather) is used.

**PROB.** Used to indicate a 30 or 40 percent probability of changing conditions that would constitute a hazard to aviation, such as thunderstorms, freezing precipitation, and low-level wind shear. The time period is indicated the same as with BECMG and TEMPO.

For example, PROB30 2817/2821 1/2SM +TSRAGR means there is a 30 percent probability between 1700Z and 2100Z on the 28<sup>th</sup> day of the month that visibility will be 1/2 statute mile with heavy thunderstorms, rain, and hail.



A probability of less than 30 percent is not considered to justify the use of the PROB group. When the probability is 50 percent or more, this shall be indicated by the use of BECMG, TEMPO, or FM, as appropriate.

### Remarks

Remarks will be prefaced by the abbreviation RMK. Remarks may include such information as when a TAF is based on observations taken by an Automated Weather Observation System (AWOS), and when there are significant discrepancies between the AWOS and a TAF. Remarks will indicate the issue date and time (UTC) of the next regular TAF.

---

## CONFIRMATION OF TEACHING POINT 4

### QUESTIONS:

- Q1. What abbreviation will be used when the ending of significant weather is forecast?
- Q2. What does the change group FM indicate?
- Q3. In which section will the issue time for the next TAF be indicated?

### ANTICIPATED ANSWERS:

- A1. NSW.
- A2. FM indicates the weather is forecast to change permanently and rapidly.
- A3. The remarks section.

---

## Teaching Point 5

**Describe an FD.**

Time: 5 min

Method: Interactive Lecture

### FDs



Show the cadets the slide of Attachment D.

**Definition**

An FD is an forecast of upper wind conditions and temperatures at selected levels. Wind direction is given in degrees true to the nearest ten degrees and wind speed is in knots.

**Decoding**



Temperatures are not forecast for 3 000 feet; in addition, this level is omitted if the terrain elevation is greater than 1 500 feet. All forecast temperatures for altitudes over 24 000 feet are negative.

When the forecast speed is less than five knots, the code group is 9900, which reads light and variable. Encoded wind speeds from 100–199 knots have 50 added to the direction code and 100 subtracted from the speed. Wind speeds that have had 50 added to the direction can be recognized when figures from 51–86 appear in the code. Since no such directions exist (eg, 510 degrees to 860 degrees), obviously they represent directions from 010 degrees to 360 degrees. Should the forecast wind speed be 200 knots or greater, the wind group is coded as 199 knots. For example, 7799 is decoded as 270 degrees at 199 knots or greater.



Show the cadets the slide of Attachment E.

Examples of decoding FD winds and temperatures are as follows (the third and fourth examples are for altitudes above 24 000 feet):

EXAMPLE	DECODED
9900+00	Wind light and variable. Temperature zero degrees Celsius.
2523	Wind 250 degrees true at 23 knots.
791159	Wind 290 degrees true ( $79 - 50 = 29$ ) at 111 knots ( $11 + 100 = 111$ ). Temperature minus 59 degrees Celsius.
859950	Wind 350 degrees true ( $85 - 50 = 35$ ) at 199 knots or greater, temperature minus 50 degrees Celsius.

Figure 1 FD Decoding

*Note.* From *Aeronautical Information Manual*. by Transport Canada, 2008, Retrieved October 27, 2008, from <http://www.tc.gc.ca/publications/EN/TP14371/PDF/HR/TP14371E.PDF>

**Where FDs are Available**

FDs can be found at several locations. The three most common locations are:

- NAV CANADA's aviation weather website,
- a Flight Services Station (FSS), and
- a Flight Information Centre (FIC) (normally accessed by phone).

---

## CONFIRMATION OF TEACHING POINT 5

### QUESTIONS:

- Q1. What is an FD?  
 Q2. At which level are temperatures not forecast?  
 Q3. What does the code group 9900 mean?

### ANTICIPATED ANSWERS:

- A1. An FD is a forecast of upper wind conditions and temperatures at selected levels.  
 A2. 3 000 feet.  
 A3. Winds are light and variable.

---

## Teaching Point 6

**Describe a GFA.**

Time: 10 min

Method: Interactive Lecture

---

### GFA's



Show the cadets the slide of Attachment F.

### Definition

A GFA consists of a series of weather charts, each depicting the most probable meteorological conditions expected to occur below 24 000 feet, over a given area at a specified time.

### Issue and Validity

GFA charts are issued four times daily, approximately 30 minutes before the beginning of the forecast period. GFAs are issued at approximately 2330, 0530, 1130, and 1730 UTC and are valid at 0000, 0600, 1200, and 1800 UTC respectively.



Each issue of the GFA is a collection of six charts; two charts valid at the beginning of the forecast period, two charts valid six hours into the forecast period and the final two charts valid twelve hours into the forecast period. Of the two charts valid at each of the three forecast periods, one chart depicts clouds and weather while the other chart depicts icing, turbulence, and freezing level. The cadets will learn to read only the GFA Clouds and Weather Chart.

## Coverage Area



Show the cadets the slide of Attachment G.

There are seven distinct GFA areas covering the entire Canadian Domestic Airspace.

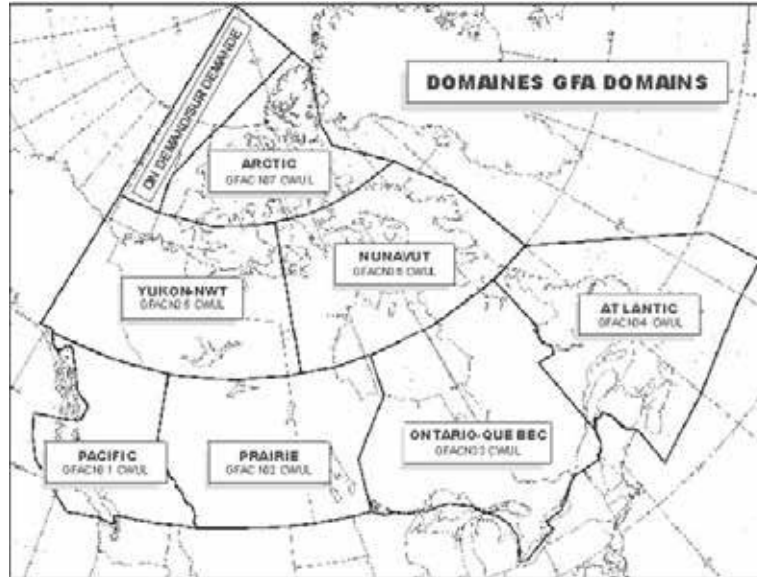

Figure 2 GFA Domains

*Note.* From *Aeronautical Information Manual*, by Transport Canada, 2008, Retrieved October 27, 2008, from <http://www.tc.gc.ca/publications/EN/TP14371/PDF/HR/TP14371E.PDF>

## Units of Measure

Speeds in a GFA are expressed in knots (kt). Horizontal visibility is measured in statute miles (SM). Times are stated in Co-ordinated Universal Time (UTC). A nautical-mile (NM) scale bar is included to assist in determining approximate distances on the chart. All heights are measured in hundreds of feet above sea level (ASL) unless otherwise noted.

## Abbreviations and Symbols



Distribute the handout of Attachment H to the cadets. Show the cadets the slide of Attachment I.

Only standard meteorological abbreviations are used in a GFA. Figure 3 is a list of common weather symbols that may be found in a GFA.

	TS	Thunderstorm
	PL	Ice Pellets
	FZRA	Freezing Rain
	FZDZ	Freezing Drizzle

Figure 3 Weather Symbols

*Note.* Created by Director Cadets 3, 2008, Ottawa, ON: Department of National Defence.

### Where GFAs are Available

GFAs can be found at several locations. The three most common locations are:

- NAV CANADA's aviation weather website,
- a Flight Services Station (FSS), and
- a Flight Information Centre (FIC) (normally accessed by phone).

---

### CONFIRMATION OF TEACHING POINT 6

#### QUESTIONS:

- Q1. How often are GFAs issued?
- Q2. How are heights measured in GFAs unless otherwise noted?
- Q3. How many distinct GFA coverage areas are there in Canada?

#### ANTICIPATED ANSWERS:

- A1. Four times daily.
- A2. In hundreds of feet above sea level (ASL).
- A3. Seven.

---

### Teaching Point 7

### Familiarize the cadets with GFA Clouds and Weather Chart layout.

Time: 15 min

Method: Interactive Lecture

### GFA CLOUDS AND WEATHER CHART LAYOUT



Indicate on the slide of Attachment F each of the following groupings as they are covered.

Each GFA chart is divided into four parts: title box, legend box, comments box, and weather information section.

<b>Weather Information Section</b>	Title Box
	Legend Box
	Comments Box

Figure 4 GFA Chart Layout

*Note.* Created by Director Cadets 3, 2008, Ottawa, ON: Department of National Defence.

### Title Box

The title box includes the chart name, issuing office four-letter identification, name of the GFA region, chart type, the date and time of issue, and the validity period.

### Legend Box

The legend box includes weather symbols that may be used in the weather information part of the GFA chart. It also includes a nautical-mile scale bar to facilitate determining distances.

### Comments Box

The comments box provides information that the weather forecaster considers important (eg, formation or dissipation of fog, increasing or decreasing visibility). It is also used to describe elements that are difficult to render pictorially or, if added to the depiction, would cause the chart to become cluttered (eg, light icing). The following standard phrases are also included in the comments box:

- HGTS ASL UNLESS NOTED,
- CB TCU AND ACC IMPLY SIG TURB AND ICG, and
- CB IMPLIES LLWS.

The comments box of the 12-hour GFA Clouds and Weather Chart also includes an Instrument Flight Rules (IFR) outlook for an additional 12-hour period in the lower section of the box. The IFR outlook is always general in nature, indicating the main areas where IFR weather is expected, the cause for the IFR weather, and any associated weather hazards.

### Weather Information Section

The weather information section of the chart depicts a forecast of the clouds and weather conditions.

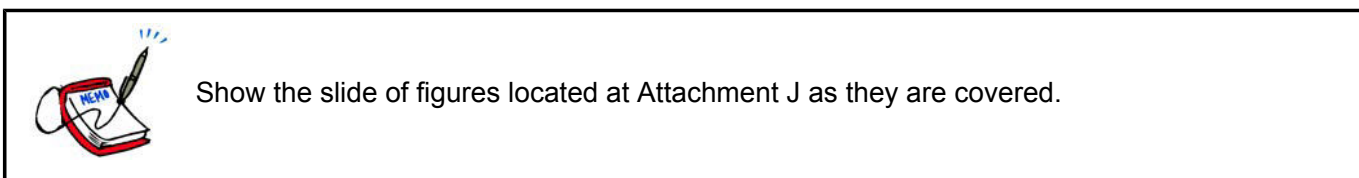

**Synoptic features.** The motion of synoptic features, when the speed of movement is forecast to be five knots or more, will be indicated by an arrow and a speed value. For speeds less than five knots, the letters QS (quasi-stationary) are used.

For example, a low pressure centre moving eastwards at 15 knots with an associated cold front moving southeast at 10 knots would be indicated as follows:



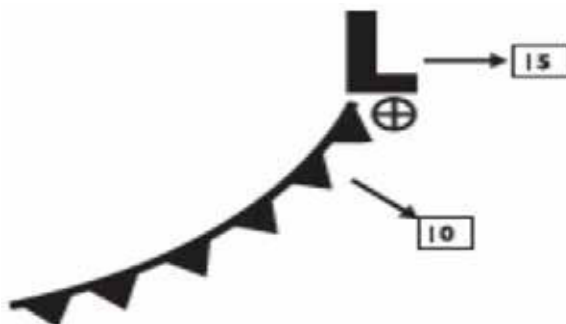

Figure 5 Synoptic Features

*Note.* From *Aeronautical Information Manual*. by Transport Canada, 2008, Retrieved October 27, 2008, from <http://www.tc.gc.ca/publications/EN/TP14371/PDF/HR/TP14371E.PDF>

**Clouds.** The bases and tops of forecast clouds between the surface and 24 000 feet ASL will be indicated. The tops of convective clouds (eg, TCU, ACC, CB) are indicated, even if they extend above 24 000 feet ASL. Cirrus clouds are not depicted on the chart. The cloud type will be indicated if considered significant, however, convective clouds such as CU, TCU, ACC, and CB will always be stated when forecast to be present.

A scalloped border encloses organized areas of clouds where the sky condition is either broken (BKN) or overcast (OVC).

For example, an organized area of broken cumulus clouds based at 2 000 feet ASL with tops at 8 000 feet ASL would be indicated as follows:

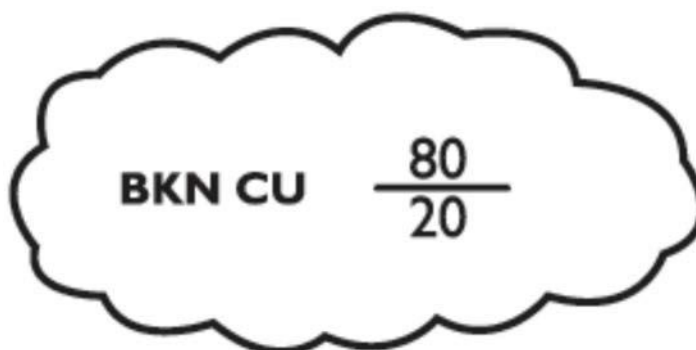

Figure 6 Broken Cumulus Clouds

*Note.* From *Aeronautical Information Manual*. by Transport Canada, 2008, Retrieved October 28, 2008, from <http://www.tc.gc.ca/publications/EN/TP14371/PDF/HR/TP14371E.PDF>

In areas where organized clouds are not forecast and the visibility is expected to be greater than six statute miles a scalloped border is not used.

For example, unorganized scattered clouds based at 3 000 feet ASL with tops at 5 000 feet ASL would be indicated as follows:

SCT  $\frac{50}{30}$

Figure 7 Scattered Clouds

*Note.* From *Aeronautical Information Manual*. by Transport Canada, 2008, Retrieved October 28, 2008, from <http://www.tc.gc.ca/publications/EN/TP14371/PDF/HR/TP14371E.PDF>

When multiple cloud layers are forecast, the bases and tops of each layer are indicated.

For example, a scattered layer of cumulus cloud based at 3 000 feet ASL with tops at 5 000 feet ASL and a higher overcast layer of altostratus cloud based at 10 000 feet ASL with tops at 13 000 feet ASL would be indicated as follows:

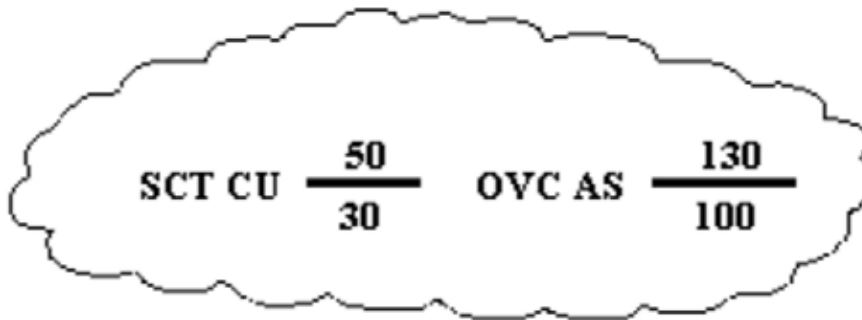

Figure 8 Multiple Cloud Layers

*Note.* From *Aeronautical Information Manual*. by Transport Canada, 2008, Retrieved October 28, 2008, from <http://www.tc.gc.ca/publications/EN/TP14371/PDF/HR/TP14371E.PDF>

**Surface-based layers.** The abbreviation OBSCD (obscured) is used to describe surface-based layers. The vertical visibility in surface-based layers is measured in hundreds of feet AGL.

For example, local obscured ceilings with a vertical visibility between 300 and 500 feet AGL would be indicated as: LCL OBSCD CIG 3 - 5 AGL.

**Visibility.** The forecast visibility is measured in statute miles. When the visibility is expected to be greater than six statute miles, it is indicated as P6SM.

For example, a forecast visibility that is expected to vary between two and four statute miles with light rain showers would be indicated as: 2 - 4 SM - SHRA.

**Weather and obstructions to vision.** Forecast weather is always included immediately after the visibility. Obstructions to vision are only mentioned when the visibility is forecast to be six statute miles or less (eg, 2 - 4SM - RA BR). Areas of showery or intermittent precipitation are shown as hatched areas enclosed by a dashed green line. Areas of continuous precipitation are shown as stippled areas enclosed by a solid green line. Areas of obstruction to vision not associated with precipitation, where visibility is six statute miles or less, are enclosed by a dashed orange line. Areas of freezing precipitation are depicted in red and enclosed by a solid red line.



Figure 9 Weather and Obstructions to Vision

*Note.* From Nav Canada, 2007, *Aviation Weather Website*. Retrieved October 28, 2008, from [http://www.flightplanning.navcanada.ca/cgi-bin/CreePage.pl?Page=info-gfa&NoSession=NS\\_Inconnu&TypeDoc=gfa&Langue=anglais#abbr\\_symb](http://www.flightplanning.navcanada.ca/cgi-bin/CreePage.pl?Page=info-gfa&NoSession=NS_Inconnu&TypeDoc=gfa&Langue=anglais#abbr_symb)

**Isobars.** Lines joining points of equal surface pressure. They are included in the GFA Clouds and Weather Chart at four-millibar intervals.

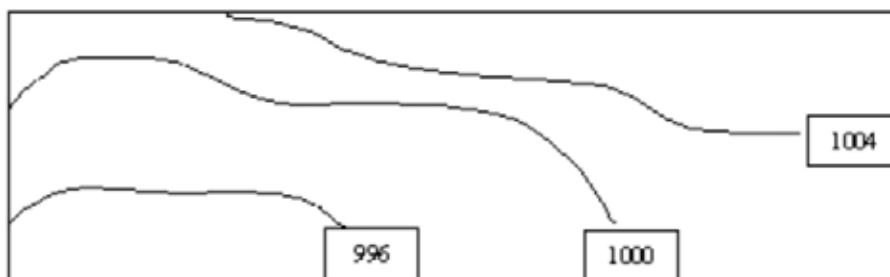

Figure 10 Isobars

*Note.* From Nav Canada, 2007, *Aviation Weather Website*. Retrieved October 28, 2008, from [http://www.flightplanning.navcanada.ca/cgi-bin/CreePage.pl?Page=info-gfa&NoSession=NS\\_Inconnu&TypeDoc=gfa&Langue=anglais#abbr\\_symb](http://www.flightplanning.navcanada.ca/cgi-bin/CreePage.pl?Page=info-gfa&NoSession=NS_Inconnu&TypeDoc=gfa&Langue=anglais#abbr_symb)

**Surface winds.** The speed and direction of forecast surface winds with a sustained speed of at least 20 knots are indicated by wind barbs and an associated wind speed value. Wind gusts are indicated by the letter G, followed by the peak gust speed in knots.

For example, surface winds forecast to be from the west (270 degrees true) with a speed of 25 knots and a peak gust speed of 35 knots would be indicated as:



Figure 11 Surface Winds

*Note.* From *Aeronautical Information Manual*. by Transport Canada, 2008, Retrieved October 28, 2008, from <http://www.tc.gc.ca/publications/EN/TP14371/PDF/HR/TP14371E.PDF>

---

## CONFIRMATION OF TEACHING POINT 7

### QUESTIONS:

- Q1. In which section of a GFA Clouds and Weather Chart would an IFR outlook be found?
- Q2. How are areas of showery or intermittent precipitation shown?
- Q3. How are organized areas of clouds where the sky condition is either broken or overcast shown?

### ANTICIPATED ANSWERS:

- A1. Comments box.
- A2. As hatched areas enclosed by a dashed green line.
- A3. Enclosed by a scalloped border.

---

## Teaching Point 8

Conduct an activity to have the cadets read METARs, TAFs, FDs and GFA Clouds and Weather Charts.

Time: 15 min

Method: In-Class Activity

---

## ACTIVITY

### OBJECTIVE

The objective of this activity is to have the cadets read METARs, TAFs, FDs and GFA Clouds and Weather Charts.

### RESOURCES

- Handouts of two or three copies of METARs, TAFs, FDs and GFA Clouds and Weather Charts in standard format,
- Copies of the same METARs, TAFs, FDs and GFA Clouds and Weather Charts in plain language format for review, and
- Abbreviations handout located at Attachment H.

### ACTIVITY LAYOUT

Nil.

### ACTIVITY INSTRUCTIONS

1. Divide the cadets into pairs.
2. Distribute the handouts of METARs, TAFs, FDs and GFA Clouds and Weather Charts in standard format among the pairs.
3. Show the cadets a sample METAR, TAF, FD and GFA Clouds and Weather Chart and demonstrate reading it.
4. Indicate a section of a METAR, TAF, FD and GFA Cloud and Weather Chart and have the cadets read it.

5. Display the copies of the same METARs, TAFs, FDs and GFA Clouds and Weather Charts in plain language format to correct the cadets' work.
6. Repeat Steps 3–5 as time permits.

**SAFETY**

Nil.

---

**CONFIRMATION OF TEACHING POINT 8**

The cadets' participation in the activity will serve as the confirmation of this TP.

---

**END OF LESSON CONFIRMATION**

The cadets' participation in the activity will serve as the confirmation of this lesson.

---

**CONCLUSION**

---

**HOMEWORK / READING / PRACTICE**

Nil.

**METHOD OF EVALUATION**

Nil.

**CLOSING STATEMENT**

Weather is a major factor in aviation. Pilots must constantly watch the weather around them as it will affect the operation and navigation of an aircraft. In particular, pilots must analyze weather information prior to flying to decide whether it is safe to fly.

**INSTRUCTOR NOTES / REMARKS**

Recent METARs, TAFs, FDs, and GFAs can be found at <http://www.flightplanning.navcanada.ca>. Click on the METAR / TAF, UPR WND (FDs), or Graphical FA icon and choose the desired region. METARs, TAFs, FDs, and GFAs can be printed in standard and plain language format.

It is recommended that the three periods required for this EO be scheduled consecutively.

Cadets who are qualified Advanced Aviation may assist with this instruction.

---

**REFERENCES**

---

C2-044 *Aeronautical Information Manual*. by Transport Canada, 2008, Retrieved September 29, 2008, from <http://www.tc.gc.ca/publications/EN/TP14371/PDF/HR/TP14371E.PDF>

C3-116 ISBN 0-9680390-5-7 MacDonald, A. F., & Peppler, I. L. (2000). *From the ground up: Millennium edition*. Ottawa, ON: Aviation Publishers Co. Limited.

THIS PAGE INTENTIONALLY LEFT BLANK

## **SAMPLE METARs AND SPECIs**

METAR CYHZ 111700Z 28009G16KT 15SM FEW250 00/  
M11 A2990 RMK CS0 SLP134=

METAR CYHZ 111800Z 29015KT 15SM FEW250 01/M10  
A2989 RMK CI0 SLP128=

METAR CYHZ 111900Z 30008KT 15SM FEW250 02/M12  
A2987 RMK CI0 SLP123=

SPECI CYYJ 111744Z CCA 23019G24KT 20SM -SHRA  
BKN014 BKN030 BKN120 09/07 RMK SC5SC1AC1=

SPECI CYYJ 111744Z 23019G24KT 20SM -RA BKN014  
BKN030 BKN120 09/07 RMK SC5SC1AC1=

THIS PAGE INTENTIONALLY LEFT BLANK



## WORLD METEOROLOGICAL ORGANIZATION CODE FOR PRESENT WEATHER

QUALIFIER			WEATHER PHENOMENA					
INTENSITY or PROXIMITY 1	DESCRIPTOR 2		PRECIPITATION 3		OBSCURATION 4		OTHER 5	
Note: Precipitation intensity refers to all forms combined.	<b>MI</b>	Shallow	<b>DZ</b>	Drizzle	<b>BR</b>	Mist (Vis $\geq$ 5/8 SM)	<b>PO</b>	Dust/ Sand Whirls (Dust Devils)
	<b>BC</b>	Patches	<b>RA</b>	Rain	<b>FG</b>	Fog (Vis $<$ 5/8 SM)	<b>SQ</b>	Squalls
	<b>PR</b>	Partial	<b>SN</b>	Snow	<b>FU</b>	Smoke (Vis $\leq$ 6 SM)	<b>+FC</b>	Tornado or Waterspout
	<b>DR</b>	Drifting	<b>SG</b>	Snow Grains				
- Light	<b>BL</b>	Blowing	<b>IC</b>	Ice Crystals (Vis $\leq$ 6 SM)	<b>DU</b>	Dust (Vis $\leq$ 6 SM)	<b>FC</b>	Funnel Cloud
	<b>SH</b>	Shower(s)						
Moderate (no qualifier)	<b>TS</b>	Thunderstorm	<b>PL</b>	Ice Pellets	<b>SA</b>	Sand (Vis $\leq$ 6 SM)	<b>SS</b>	Sandstorm (Vis $<$ 5/8 SM) (+SS Vis $<$ 516 SM)
			<b>GR</b>	Hail				
+ Heavy	<b>FZ</b>	Freezing	<b>GS</b>	Snow Pellets	<b>HZ</b>	Haze (Vis $\leq$ 6 SM)	<b>DS</b>	Dust storm (Vis $<$ 5/8 SM) (+DS Vis $<$ 516 SM)
VC In the vicinity			<b>UP</b>	Unknown precipitation (AWOS only)	<b>VA</b>	Volcanic Ash (with any visibility)		

Figure B-1 World Meteorological Organization Code for Present Weather

Note. From *Aeronautical Information Manual* (p. 145), by Transport Canada, 2008, Ottawa, ON: Transport Canada. Copyright 2007 by Her Majesty the Queen in Right of Canada.

THIS PAGE INTENTIONALLY LEFT BLANK

## SAMPLE TAFs

TAF CYHZ 201738Z 2018/2118 25008KT P6SM OVC015  
TEMPO 2018/2020 OVC025  
FM202000 24010KT P6SM OVC025 TEMPO 2020/2022 OVC020  
FM202200 23012KT P6SM BKN030  
FM210200 23010KT P6SM SCT030  
RMK NXT FCST BY 202100Z=

TAF CYVR 201739Z 2018/2124 10012G22KT P6SM -RA SCT025  
OVC050 TEMPO 2021/2103 5SM -RA BR BKN020  
BECMG 2021/2022 14012G22KT  
BECMG 2101/2102 28020G30KT  
FM210300 28020G30KT P6SM FEW030 SCT060  
BECMG 2103/2104 26012KT  
FM210800 11005KT P6SM -SHRA BKN030  
BECMG 2110/2112 14010G20KT  
FM211600 12012G22KT 5SM -RA BR SCT008 BKN012  
RMK NXT FCST BY 202100Z=

TAF CYYG 201738Z 2018/2106 25012KT P6SM FEW009 OVC015  
TEMPO 2018/2020 6SM -SHSN BKN009  
FM202300 24012KT P6SM BKN025 TEMPO 2023/2102 BKN020  
FM210200 26008KT P6SM SCT025 TEMPO 2102/2106 BKN025  
RMK NXT FCST BY 210000Z=

TAF CYOW 201738Z 2018/2118 34012KT P6SM BKN040  
FM202200 31005KT P6SM FEW050 SCT100  
FM211600 31012KT P6SM BKN030  
RMK NXT FCST BY 202100Z=

THIS PAGE INTENTIONALLY LEFT BLANK

## SAMPLE FDS

<b>STN YNA - NATASHQUAN. QUEBEC</b>	<b>for use</b>	<b>3000</b>	<b>6000</b>	<b>9000</b>	<b>12000</b>	<b>18000</b>
FDCN01 CWAO FCST BASED ON 271200 DATA <b>VALID 271800</b>	<b>17-21</b>	2130	2129+05	2131+03	2140-03	2158-11
FDCN02 CWAO FCST BASED ON 271200 DATA <b>VALID 280000</b>	<b>21-06</b>	1916	1917+06	2023+03	2130-02	2152-11
FDCN03 CWAO FCST BASED ON 271200 DATA <b>VALID 281200</b>	<b>06-17</b>	1635	1633+05	1929+03	1936+00	1838-11

<b>STN YQI - YARMOUTH. NS</b>	<b>for use</b>	<b>3000</b>	<b>6000</b>	<b>9000</b>	<b>12000</b>	<b>18000</b>
FDCN01 CWAO FCST BASED ON 271200 DATA <b>VALID 271800</b>	<b>17-21</b>	1616	1919+10	1936+05	1934+00	2043-10
FDCN02 CWAO FCST BASED ON 271200 DATA <b>VALID 280000</b>	<b>21-06</b>	1842	1843+11	1843+06	1842+00	1842-10
FDCN03 CWAO FCST BASED ON 271200 DATA <b>VALID 281200</b>	<b>06-17</b>	1451	1551+10	1537+04	1651+00	1865-08

<b>STN YQI - YARMOUTH. NS</b>	<b>for use</b>	<b>24000</b>	<b>30000</b>	<b>34000</b>	<b>39000</b>	<b>45000</b>	<b>53000</b>
FDCN01 KWBC DATA BASED ON 271200Z <b>VALID 271800Z</b>	<b>1700-2100Z.</b>	2145-24	225139	225248	206558	215363	213964
FDCN02 KWBC DATA BASED ON 271200Z <b>VALID 280000Z</b>	<b>2100-0600Z.</b>	2043-23	215140	215149	214558	215062	213864
FDCN03 KWBC DATA BASED ON 271200Z <b>VALID 281200Z</b>	<b>0600-1700Z.</b>	1855-23	195738	205047	226656	216062	204264

THIS PAGE INTENTIONALLY LEFT BLANK

## Decoding FDs

EXAMPLE	DECODED
9900+00	Wind light and variable, temperature zero degrees Celsius.
2523	Wind 250 degrees true at 23 knots.
791159	Wind 290 degrees true ( $79 - 50 = 29$ ) at 111 knots ( $11 + 100 = 111$ ), temperature -59 degrees Celsius.
859950	Wind 350 degrees true ( $85 - 50 = 35$ ) at 199 knots or greater, temperature -50 degrees Celsius.

Figure E-1 FD Decoding

*Note.* From *Aeronautical Information Manual*. by Transport Canada, 2008, Retrieved October 27, 2008, from <http://www.tc.gc.ca/publications/EN/TP14371/PDF/HR/TP14371E.PDF>

THIS PAGE INTENTIONALLY LEFT BLANK



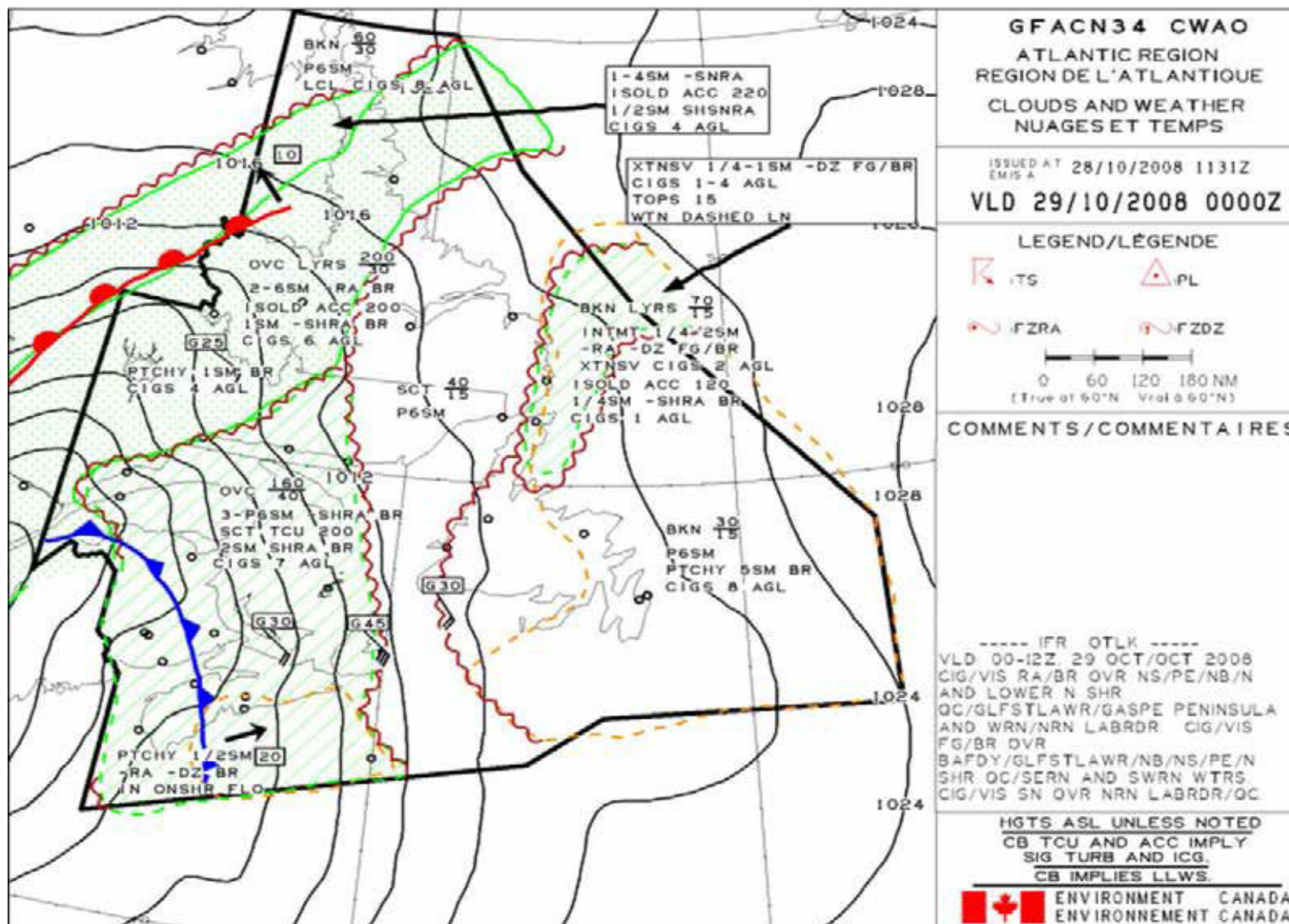

Figure F-1 GFA Clouds and Weather Chart

Note. From Nav Canada, 2007, *Aviation Weather Website*. Retrieved October 28, 2008, from [http://www.flightplanning.navcanada.ca/cgi-bin/CreePage.pl?Langue=anglais&NoSession=NS\\_Inconnu&Page=forecast-observation&TypeDoc=html](http://www.flightplanning.navcanada.ca/cgi-bin/CreePage.pl?Langue=anglais&NoSession=NS_Inconnu&Page=forecast-observation&TypeDoc=html)

THIS PAGE INTENTIONALLY LEFT BLANK

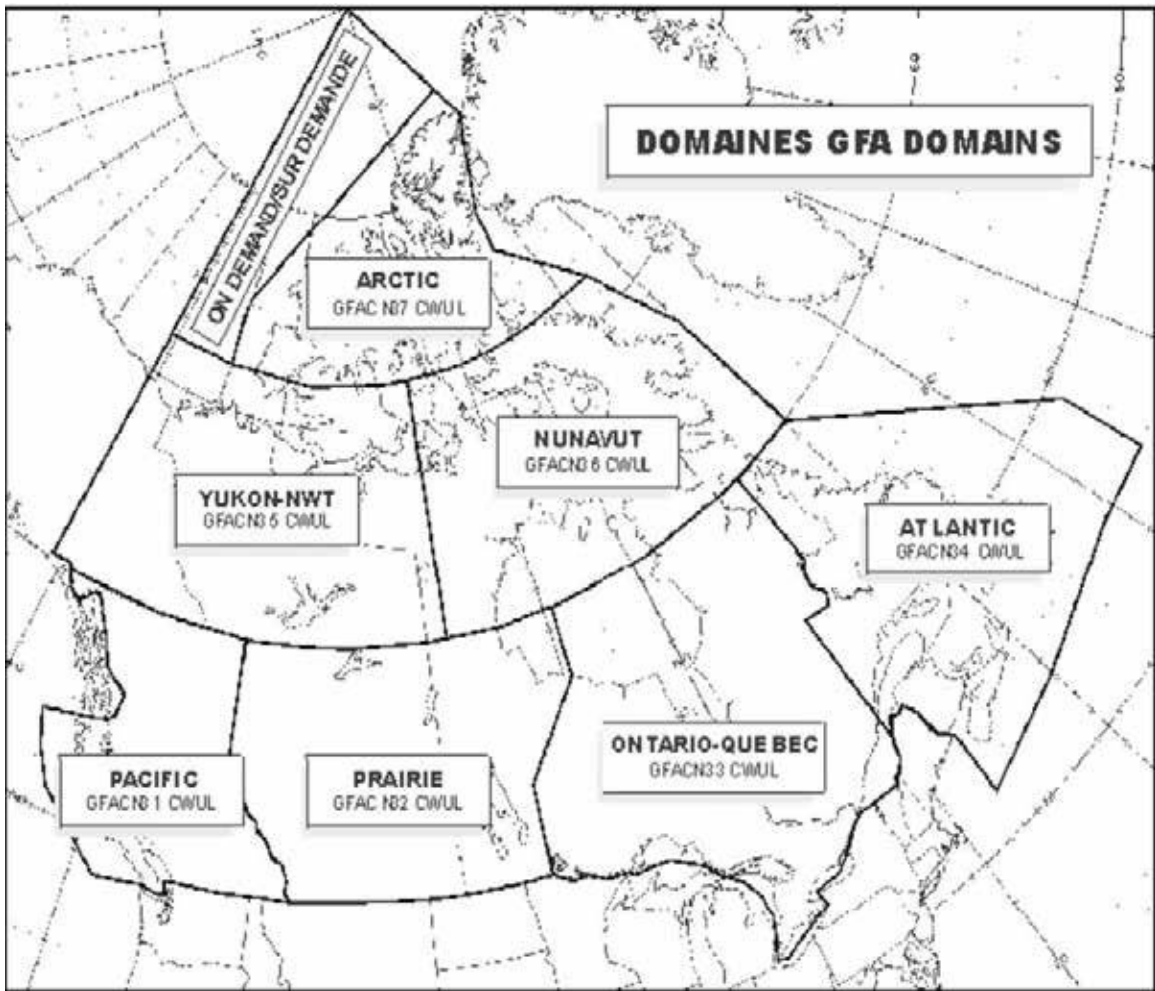

Figure G-1 GFA Domains

*Note.* From *Aeronautical Information Manual*. by Transport Canada, 2008, Retrieved October 27, 2008, from <http://www.tc.gc.ca/publications/EN/TP14371/PDF/HR/TP14371E.PDF>

THIS PAGE INTENTIONALLY LEFT BLANK

### 3.6 ABBREVIATIONS – AVIATION FORECASTS

CONTRACTION	PLAIN LANGUAGE	CONTRACTION	PLAIN LANGUAGE
ABV	above	CLRG	clearing
ACCAS	altocumulus castellanus	CNTR	centre
ACRS	across	CNTRD	centred
ACSL	standing lenticular altocumulus	CONDS	conditions
ACT	active	COTRAILS	condensation trails
AFT	after	CONTUS	continuous
AFL	above freezing layer	CONTG	continuing
AHD	ahead	CST	coast
ALF	aloft	CU	cumulus
ALG	along	DCRG	decreasing
ALT	altitude	DEG	degree
AIRMS	air mass	DFUS	diffuse
APCH	approach	DIST	distant
APCHG	approaching	DNS	dense
ASL	above sea level	DNSLP	downslope
AWOS	Automated Weather Observation System	DP	deep
BECMG	becoming	DPNG	deepening
BFR	before	DRFTG	drifting
BGN	begin	DURG	during
BGNG	beginning	DVLPG	developing
BHND	behind	DZ	drizzle
BKN	broken	E	east
BL	blowing	ELSW	elsewhere
BLDG	building	ELY	easterly
BLO	below	EMBD	embed
BLZD	blizzard	ENDG	ending
BDRY	boundary	ENTR	entire
BR	mist	FCST	forecast
BRF	brief	FEW	few clouds
BRFLY	briefly	FG	fog
BRKS	breaks	FILG	filling
BTN	between	FLWD	followed
CAT	clear air turbulence	FLWG	following
CAVOK	ceiling and visibility OK	FM	from
CB	cumulonimbus	FNT	front
CIG	ceiling	FRQ	frequent
CLD	cloud	FZLVL	freezing level
CLR	clear	FROIN	frost on indicator
		FROPA	frontal passage
		FRO	frequent

Figure H-1 Abbreviations

*Note.* From *Aeronautical Information Manual*. by Transport Canada, 2008, Retrieved October 27, 2008, from <http://www.tc.gc.ca/publications/EN/TP14371/PDF/HR/TP14371E.PDF>

CONTRACTION	PLAIN LANGUAGE	CONTRACTION	PLAIN LANGUAGE
FT	feet, foot	MDFYD	modified
FU	smoke	MDT	moderate
FZ	freezing	MI	shallow
GND	ground	MID	middle
GRAD	gradient	MOVG	moving
GRDLY	gradually	MPH	miles per hour
HGT	height	MRNG	morning
HI	high	MRTM	maritime
HLTP	hilltop	MSTR	moisture
HND	hundred	MTS	mountains
HR	hour	MVFR	marginal VFR
HVY	heavy	MXD	mixed
ICG	icing	MXG	mixing
ICGIC	icing in cloud	N	north
ICGIP	icing in precipitation	NE	northeast
IMDTLY	immediately	NELY	northeasterly
INCRG	increasing	NGT	night
INDEF	indefinite	NLY	northerly
INSTBY	instability	NM	nautical mile(s)
INTMT	intermittent	NMRS	numerous
INTS	intense	NR	near
INTSFY	intensify	NRLY	nearly
ISLD	island	NSW	no significant weather
ISOL	isolate(d)	NW	northwest
KT	knot(s)	NWLY	northwesterly
LCL	local	OBSC	obscure(d)
LFTG	lifting	OCLD	occlude
LGT	light	OCLDG	occluding
LIFR	low IFR	OCLN	occlusion
LK	lake	OCNL	occasional
LLJ	low level jet stream	OCNLY	occasionally
LLWS	low level wind shear	OFSHR	offshore
LN	line	ONSHR	onshore
LO	low	ORGPHC	orographic
LTL	little	OTLK	outlook
LVL	level	OTWZ	otherwise
LWIS	limited weather information system	OVC	overcast
LWR	lower	OVR	over
LWRG	lowering	OVRNG	overrunning
LYR	layer	PCPN	precipitation

Figure H-2 Abbreviations

*Note.* From *Aeronautical Information Manual*. by Transport Canada, 2008, Retrieved October 27, 2008, from <http://www.tc.gc.ca/publications/EN/TP14371/PDF/HR/TP14371E.PDF>

CONTRACTION	PLAIN LANGUAGE	CONTRACTION	PLAIN LANGUAGE
PD	period	SPECI	special
PL	ice pellets	SPRDG	spreading
PRECDD	preceded	SQ	squall
PRECDS	precedes	STBL	stable
PRES	pressure	STG	strong
PROG	prognostic, prognosis	STGTN	strengthen
PRSTG	persisting	STNRY	stationary
PSG	passage, passing	SEV	severe
PSN	position	SVRL	several
PTCHY	patchy	SW	southwest
PTLY	partly	SWLY	southwesterly
RA	rain	SXN	section
RDG	ridge	SYS	system
RFRMG	reforming	T	temperature
RGN	region	TCU	towering cumulus
RMNG	remaining	TEMPO	temporary
RPDLY	rapidly	THK	thick
RPRT	report	THKNG	thickening
RSG	rising	THN	thin
RUF	rough	THNC	thence
RVR	river	THNG	thinning
S	south	THRU	through
SCT	scattered	THRUT	throughout
SCTR	sector	THSD	thousand
SE	southeast	TILL	until
SELY	southeasterly	TRML	terminal
SFC	surface	TROF	trough
SH	shower	TROWAL	trough of warm air aloft
SHFT	shift	TRRN	terrain
SHFTG	shifting	TS	thunderstorm
SHLW	shallow	TURB	turbulence
SKC	sky clear	TWD	toward
SLO	slow	UNSTBL	unstable
SLOLY	slowly	UPR	upper
SLY	southerly	UPSLP	upslope
SM	statute mile(s)	UTC	co-ordinated universal time
SML	small	VC	vicinity
SN	snow	VLY	valley
SNRS	sunrise	VRB	variable
SNST	sunset	VIS	visibility

Figure H-3 Abbreviations

*Note.* From *Aeronautical Information Manual*. by Transport Canada, 2008, Retrieved October 27, 2008, from <http://www.tc.gc.ca/publications/EN/TP14371/PDF/HR/TP14371E.PDF>

CONTRACTION	PLAIN LANGUAGE
VV	vertical visibility
W	west
WDLY	widely
WK	weak
WLY	westerly
WND	wind
WRM	warm
WS	wind shear
WV	wave
WX	weather
XCP	except
XT	extend
XTDG	extending
XTRM	extreme
XTSV	extensive
Z	ZULU (or UTC)

Figure H-4 Abbreviations

*Note.* From *Aeronautical Information Manual*. by Transport Canada, 2008, Retrieved October 27, 2008, from <http://www.tc.gc.ca/publications/EN/TP14371/PDF/HR/TP14371E.pdf>



## GFA Weather Symbols

	TS	Thunderstorm
	PL	Ice Pellets
	FZRA	Freezing Rain
	FZDZ	Freezing Drizzle

Figure I-1 Weather Symbols

*Note.* Created by Director Cadets 3, 2008, Ottawa, ON: Department of National Defence.

THIS PAGE INTENTIONALLY LEFT BLANK

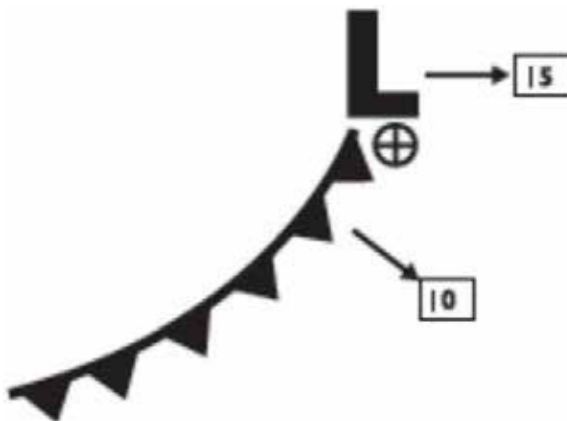

Figure J-1 Synoptic Features

*Note.* From *Aeronautical Information Manual*. by Transport Canada, 2008, Retrieved October 27, 2008, from <http://www.tc.gc.ca/publications/EN/TP14371/PDF/HR/TP14371E.PDF>

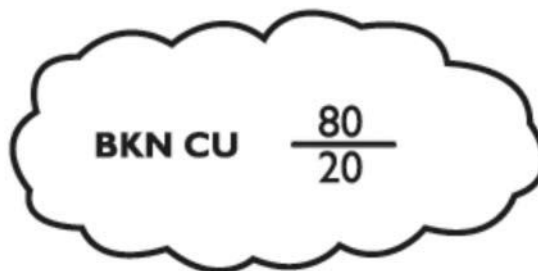

Figure J-2 Broken Cumulus Clouds

*Note.* From *Aeronautical Information Manual*. by Transport Canada, 2008, Retrieved October 27, 2008, from <http://www.tc.gc.ca/publications/EN/TP14371/PDF/HR/TP14371E.PDF>

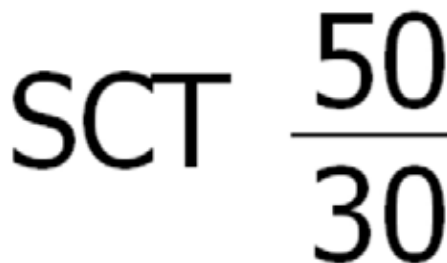

Figure J-3 Scattered Clouds

*Note.* From *Aeronautical Information Manual*. by Transport Canada, 2008, Retrieved October 27, 2008, from <http://www.tc.gc.ca/publications/EN/TP14371/PDF/HR/TP14371E.PDF>

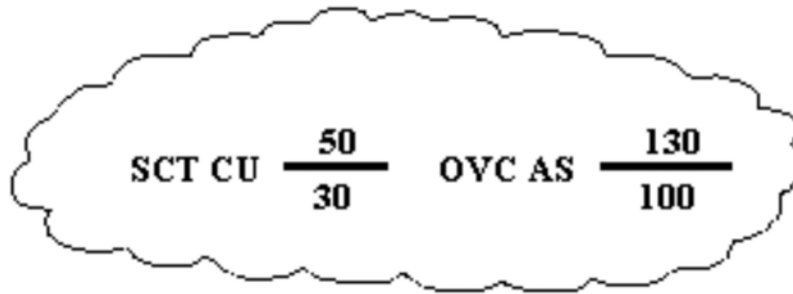

Figure J-4 Multiple Cloud Layers

Note. From *Aeronautical Information Manual*. by Transport Canada, 2008, Retrieved October 27, 2008, from <http://www.tc.gc.ca/publications/EN/TP14371/PDF/HR/TP14371E.PDF>

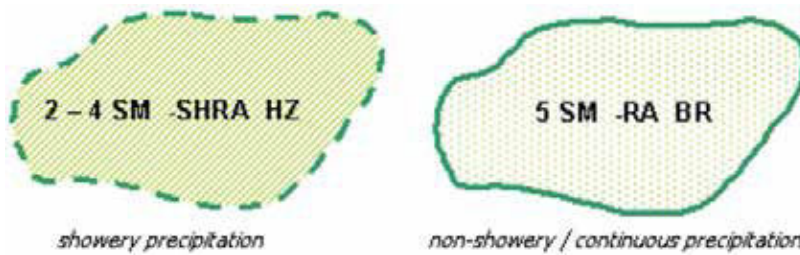

Figure J-5 Weather and Obstructions to Vision

Note. From Nav Canada, 2007, *Aviation Weather Website*. Retrieved October 28, 2008, from [http://www.flightplanning.navcanada.ca/cgi-bin/CreePage.pl?Page=info-gfa&NoSession=NS\\_Inconnu&TypeDoc=gfa&Langue=anglais#abbr\\_symb](http://www.flightplanning.navcanada.ca/cgi-bin/CreePage.pl?Page=info-gfa&NoSession=NS_Inconnu&TypeDoc=gfa&Langue=anglais#abbr_symb)

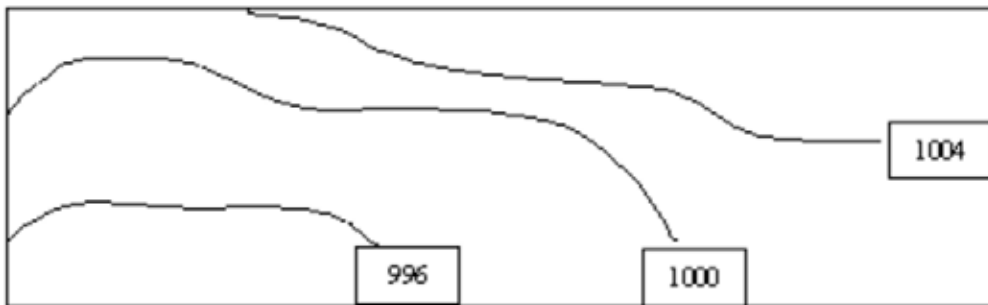

Figure J-6 Isobars

Note. From Nav Canada, 2007, *Aviation Weather Website*. Retrieved October 28, 2008, from [http://www.flightplanning.navcanada.ca/cgi-bin/CreePage.pl?Page=info-gfa&NoSession=NS\\_Inconnu&TypeDoc=gfa&Langue=anglais#abbr\\_symb](http://www.flightplanning.navcanada.ca/cgi-bin/CreePage.pl?Page=info-gfa&NoSession=NS_Inconnu&TypeDoc=gfa&Langue=anglais#abbr_symb)



Figure J-7 Surface Winds

Note. From *Aeronautical Information Manual*. by Transport Canada, 2008, Retrieved October 27, 2008, from <http://www.tc.gc.ca/publications/EN/TP14371/PDF/HR/TP14371E.PDF>



**ROYAL CANADIAN AIR CADETS**  
**PROFICIENCY LEVEL FOUR**  
**INSTRUCTIONAL GUIDE**



**SECTION 1**

**EO M437.01 – DEFINE AIR NAVIGATION TERMS**

---

Total Time:	60 min
-------------	--------

---

**PREPARATION**

---

**PRE-LESSON INSTRUCTIONS**

Resources needed for the delivery of this lesson are listed in the lesson specification located in A-CR-CCP-804/PG-001, *Proficiency Level Four Qualification Standard and Plan*, Chapter 4. Specific uses for said resources are identified throughout the instructional guide within the TP for which they are required.

Review the lesson content and become familiar with the material prior to delivering the lesson.

Photocopy the handout located at Attachment A for each cadet.

Prepare slides of the figures located at Attachment B.

Photocopy the Headings and Bearings Worksheet located at Attachment C for each cadet.

**PRE-LESSON ASSIGNMENT**

Nil.

**APPROACH**

An interactive lecture was chosen for TPs 1–3 to clarify, emphasize, and summarize navigation terms.

An in-class activity was chosen for TP 4 as it is an interactive way to reinforce bearings and headings, and confirm the cadets' comprehension of navigation terms.

---

**INTRODUCTION**

---

**REVIEW**

Nil.

**OBJECTIVES**

By the end of this lesson the cadet shall be expected to define air navigation terms.

**IMPORTANCE**

It is important for cadets to define air navigation terms to ensure a firm foundation in navigation before learning more advanced material. Knowledge of air navigation terms is essential for future aviation training and potential instructional duties at the squadron.

**Teaching Point 1**

**Define meridians of longitude, parallels of latitude, geographical co-ordinates, and the relationship between time and longitude.**

Time: 25 min

Method: Interactive Lecture



Use a large globe to point out the meridians of longitude and parallels of latitude.

**MERIDIANS OF LONGITUDE**

**Meridians of longitude.** Semicircles joining the true / geographic poles of the Earth.

Longitude is measured from 0–180 degrees east and west of the prime meridian. The prime meridian is the meridian which passes through Greenwich, England and is numbered zero degrees. The meridian on the opposite side of the Earth to the prime meridian is the 180<sup>th</sup> and is called the international date line (the time changes a day).

Longitude is measured in degrees ( ° ), minutes ( ' ), and seconds ( " ). There are 60 minutes in a degree and 60 seconds in a minute.



When dealing with longitude and latitude, seconds and minutes are not measurements of time but rather divisions of a degree. This can be compared to the way that a metre is divided into 100 cm and each centimetre is divided into 10 mm.

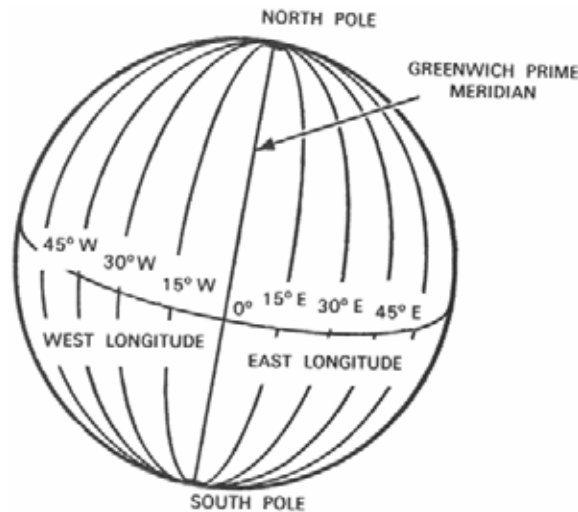

Figure 1 Meridians of Longitude

*Note.* From "Air Cadet Master Lesson Plans", 2007, *Cadets Canada: RCSU Pacific*. Retrieved November 14, 2007, from [http://www.regions.cadets.ca/pac/aircad/resources/mlp\\_air\\_e.asp](http://www.regions.cadets.ca/pac/aircad/resources/mlp_air_e.asp)

**PARALLELS OF LATITUDE**

**Parallels of latitude.** Circles on the Earth's surface that lie parallel to the equator.

**Equator.** An imaginary line on the surface of the Earth equidistant from the poles.

Latitude is measured from 0–90 degrees north and south of the equator, which is numbered zero degrees. Like longitude, latitude is measured in degrees, minutes, and seconds.

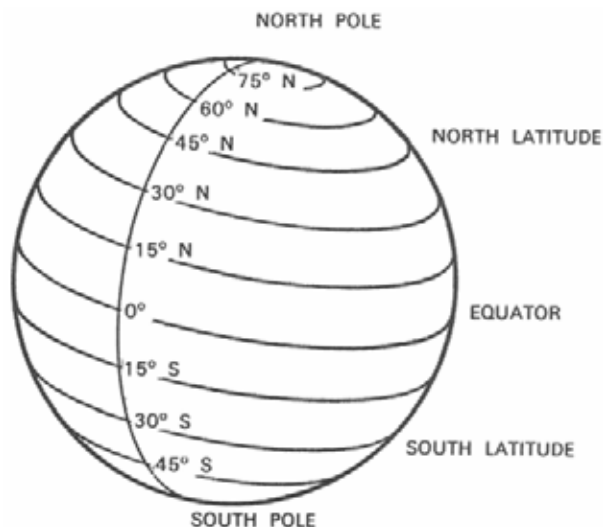

Figure 2 Parallels of Latitude

*Note.* From "Air Cadet Master Lesson Plans", 2007, *Cadets Canada: RCSU Pacific*. Retrieved November 14, 2007, from [http://www.regions.cadets.ca/pac/aircad/resources/mlp\\_air\\_e.asp](http://www.regions.cadets.ca/pac/aircad/resources/mlp_air_e.asp)



Remember the difference between latitude and longitude using one of the following mnemonics:

- Lat is flat / fat; longitude is long.
- Latitude is like climbing up a ladder because it is north / south; longitude is like swinging across because it is east / west.

## GEOGRAPHICAL CO-ORDINATES

**Geographical co-ordinates.** The intersection of lines of latitude and longitude. Geographical co-ordinates mark the position of places (eg, cities, towns, airports) on a chart.

On a chart, there are black lines representing longitude and latitude, every 30 minutes. Small marks represent 1 minute. There are slightly larger marks for 5 minute and 10 minute increments.



Distribute the handout located at Attachment A to each cadet.

Have the cadets find markings on a line of latitude or longitude to represent 1 minute, 5 minutes, and 10 minutes using a local VFR Navigation Chart (VNC).

Co-ordinates express latitude first, in degrees north or south of the equator and longitude second, in degrees east or west of the prime meridian. For example, the geographical coordinates of the military airport at Trenton, Ont. are 44°07' N, 77°32' W.



The location of the military airport at Trenton, Ont. has been chosen as an example because it appears on the sample VNC provided in the back of *From The Ground Up: Millennium Edition*.

The grid surrounding this airport can be found at Attachment A.



Select a major airport in the area and have the cadets find the coordinates using a local VNC.

## THE RELATIONSHIP BETWEEN TIME AND LONGITUDE

The Earth rotates about its axis as it revolves in an elliptical orbit around the Sun. This creates the illusion that the Sun is revolving around the Earth. The time between one apparent passage of the Sun over a meridian of longitude is called an apparent solar day and varies throughout the year. To provide a convenient method of measuring time, it has been averaged to a mean solar day, divided into 24 hours. During the mean solar day, the Sun is assumed to travel once around the Earth, thereby travelling through 360 degrees of longitude. Hence, mean time can be expressed in terms of longitude and vice versa.

For example:

- 24 hours = 360 degrees of longitude
- 1 hour = 15 degrees of longitude
- 1 minute = 15 minutes of longitude
- 1 second = 15 seconds of longitude
- 360 degrees of longitude = 24 hours
- 1 degree of longitude = 4 minutes
- 1 minute of longitude = 4 seconds
- 1 second of longitude = 1/15 second

**Local mean time (LMT).** The mean time on any particular meridian.

**Co-ordinated universal time (UTC).** An atomically measured global standard time, calculated from midnight on the zero meridian. UTC is also referred to as Zulu (Z) time.



UTC replaced Greenwich mean time (GMT) which was the universally accepted standard for the measurement of time until December, 1985.

UTC is the LMT for the prime meridian.

The LMT of any place east of the prime meridian is ahead of UTC. For example, 1200 hours LMT in Cairo is 1000Z.

The LMT of any place west of the prime meridian is behind UTC. For example, 1200 hours LMT in Halifax is 1600Z.





Tell the cadets how many hours are added to LMT to find UTC in their location.



Use a large globe to indicate the time zones.

The world is divided into 24 time zones, each 15 degrees of longitude (one hour) wide. When travelling westward into a new time zone, time is turned back one hour. When travelling eastward into a new time zone, time is turned ahead one hour.



One exception to this is Newfoundland Standard Time, which is 1/2 hour ahead of Atlantic Standard Time.

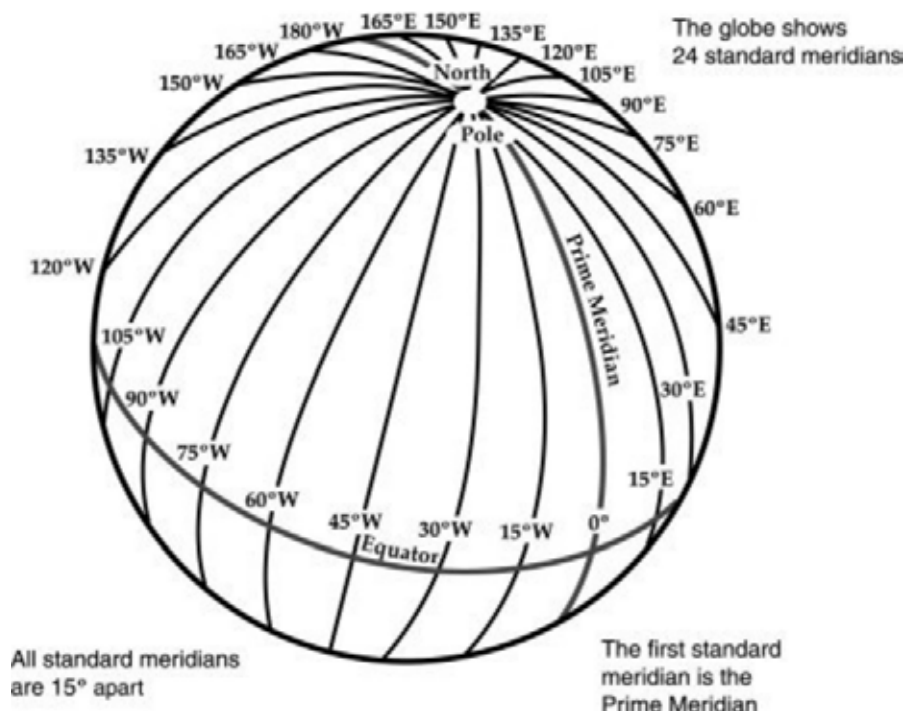

Figure 3 Meridians of Longitude

*Note.* From "Globe Lesson 12", *1-World Maps Online*, Copyright 2008 by 1-World Maps Online. Retrieved November 25, 2008, from <http://www.worldmapsonline.com/LESSON-PLANS/6-global-time-globe-lesson-12.htm>



Part of our heritage: Sir Sandford Fleming, a Canadian railway planner and engineer, outlined a plan for worldwide standard time in the late 1870s. Following this initiative, in 1884, delegates from 27 nations met in Washington, D.C. for the Meridian Conference and agreed on a system basically the same as that now in use.

---

## CONFIRMATION OF TEACHING POINT 1

### QUESTIONS:

- Q1. What are meridians of longitude?
- Q2. How are parallels of latitude measured?
- Q3. What must be done to LMT in Canada to convert it to UTC?

### ANTICIPATED ANSWERS:

- A1. Semicircles joining the true / geographic poles of the Earth.
- A2. From 0–90 degrees north and south of the equator.
- A3. The appropriate number of hours must be added.

---

## Teaching Point 2

Define great circles and rhumb lines.

Time: 10 min

Method: Interactive Lecture

---

## GREAT CIRCLES



Show the slide of Figures B-1 and B-2 to the cadets.

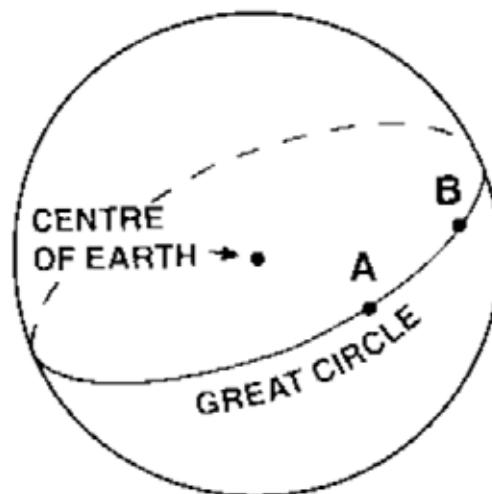

Figure 4 Great Circle

*Note. From From the Ground Up: Millennium Edition (p. 177), by A. F. MacDonald and I. L. Peppler, 2000, Ottawa, ON: Aviation Publishers Co. Limited. Copyright 2000 by Aviation Publishers Co. Limited.*

**Great circle.** A circle on the surface of a sphere that passes through the centre of the sphere, cutting it into two equal parts.

The equator is a great circle. The meridians of longitude are semi-great circles as they run from pole to pole and do not completely encircle the Earth.

Only one great circle can be drawn through two places that are not diametrically opposite each other. The shortest distance between these two points is the shorter arc of the great circle joining them. Therefore, most long-distance flights are flown over great circle routes.

A great circle does not cross the meridians it meets at the same angle. Therefore, the heading must be changed at frequent intervals to enable the airplane to maintain a great circle route.

## RHUMB LINES



Show the slide of Figures B-3 and B-4 to the cadets.

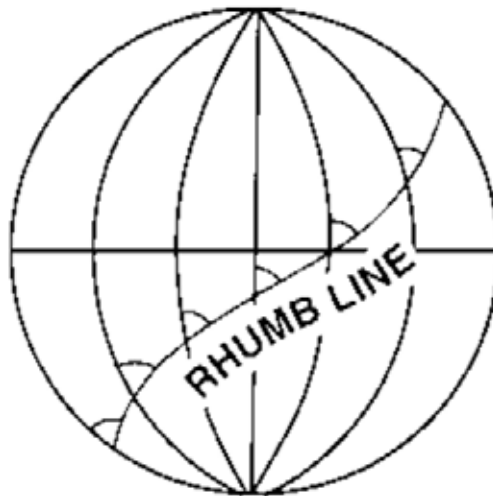

Figure 5 Rhumb Line

*Note.* From *From the Ground Up: Millennium Edition* (p. 177), by A. F. MacDonald and I. L. Pepler, 2000, Ottawa, ON: Aviation Publishers Co. Limited. Copyright 2000 by Aviation Publishers Co. Limited.

**Rhumb line.** A curved line on the surface of the Earth, cutting all the meridians it meets at the same angle.

All parallels of latitude are rhumb lines. The meridians of longitude and the equator are rhumb lines as well as great circles.



Show the slide of Figures B-5 and B-6 to the cadets.

When two places are not situated on the equator or on the same meridian of longitude, the distance measured along the rhumb lines joining them will not be the shortest distance between them. The advantage of the rhumb line route is that the direction is constant, allowing a navigator to follow a constant heading.

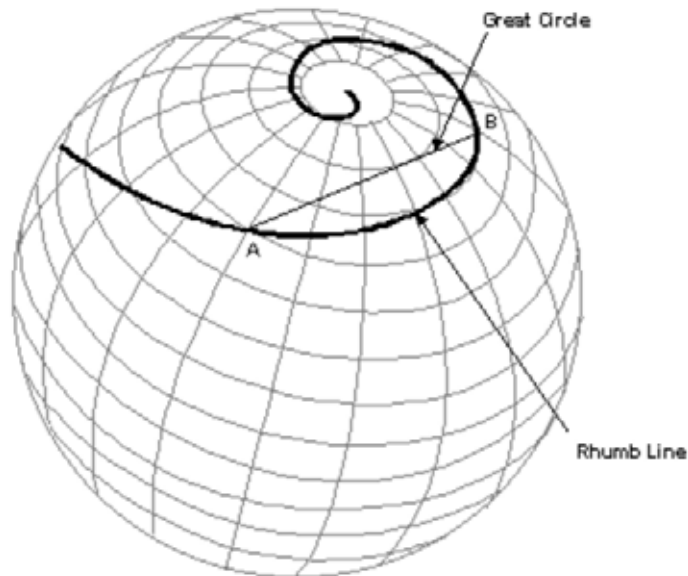

The great circle is a straight line and  
the Rhumb line is a spiral curve

Figure 6 Great Circle and Rhumb Line

Note. From "Flights", *Navworld*. Retrieved November 26, 2008, <http://www.navworld.com/navcerebrations/flights.htm>

---

## CONFIRMATION OF TEACHING POINT 2

### QUESTIONS:

- Q1. What is a great circle?
- Q2. What is a rhumb line?
- Q3. What is the advantage of following a rhumb line route?

### ANTICIPATED ANSWERS:

- A1. A circle on the surface of a sphere that passes through the centre of the sphere, cutting it into two equal parts.
- A2. A curved line on the surface of the Earth, cutting all the meridians it meets at the same angle.
- A3. The direction is constant, allowing a navigator to follow a constant heading.

---

## Teaching Point 3

## Define headings and bearings.

Time: 5 min

Method: Interactive Lecture

---

## HEADINGS AND BEARINGS

Direction is measured in degrees clockwise from north, which is zero degrees (or 360 degrees). East is 90 degrees, south is 180 degrees, and west is 270 degrees.



Show the slide of Figure B-7 to the cadets.



Figure 7 Heading

*Note.* From *From the Ground Up: Millennium Edition* (p. 177), by A. F. MacDonald and I. L. Peppler, 2000, Ottawa, ON: Aviation Publishers Co. Limited. Copyright 2000 by Aviation Publishers Co. Limited.

**True heading.** The angle between the meridian of longitude over which an airplane is flying and the line representing the direction the airplane's nose is pointing, measured clockwise from the meridian.



Show the slide of Figure B-8 to the cadets.

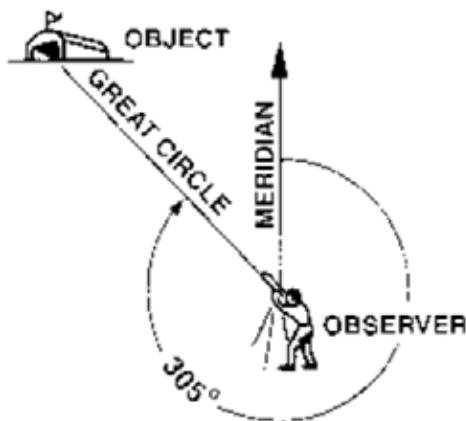

Figure 8 Bearing

*Note.* From *From the Ground Up: Millennium Edition* (p. 177), by A. F. MacDonald and I. L. Peppler, 2000, Ottawa, ON: Aviation Publishers Co. Limited. Copyright 2000 by Aviation Publishers Co. Limited.

The direction of any point on the surface of the Earth from an observer is known by measuring the bearing.

**Bearing.** The angle between the meridian of longitude passing through the observer and the great circle that joins the observer to the object, measured clockwise from the meridian.

Headings and bearings are found using a compass.

---

### CONFIRMATION OF TEACHING POINT 3

#### QUESTIONS:

- Q1. How is direction measured?
- Q2. Define true heading.
- Q3. Define bearing.

#### ANTICIPATED ANSWERS:

- A1. In degrees clockwise from north.
- A2. The angle between the meridian of longitude over which an airplane is flying and the line representing the direction the airplane's nose is pointing, measured clockwise from the meridian.
- A3. The angle between the meridian of longitude passing through the observer and the great circle that joins the observer to the object, measured clockwise from the meridian.

---

### Teaching Point 4

**Have the cadets take headings and bearings.**

Time: 10 min

Method: In-Class Activity

---

## ACTIVITY

### OBJECTIVE

The objective of this activity is to have the cadets take headings and bearings.

### RESOURCES

- Douglas Protractor,
- Pen / Pencil, and
- Headings and Bearings Worksheet located at Attachment C.

### ACTIVITY LAYOUT

Nil.

### ACTIVITY INSTRUCTIONS

1. Distribute a Douglas protractor to each cadet.
2. Distribute a Headings and Bearings Worksheet to each cadet.
3. Designate an object in the room as representing magnetic north.
4. Have the cadets take the magnetic headings of the aircraft in Section 1 of the worksheet.

5. Review and correct the answers.
6. Designate a different object in the room as representing true north.
7. Have the cadets take the bearing of the tower from the aircraft in Section 2 of the worksheet.
8. Review and correct the answers.

**SAFETY**

Nil.

---

**CONFIRMATION OF TEACHING POINT 4**

The cadets' participation in the activity will serve as the confirmation of the TP.

---

**END OF LESSON CONFIRMATION****QUESTIONS:**

- Q1. How many degrees of longitude are equal to one hour?
- Q2. What is the shortest distance between two places on the surface of the Earth?
- Q3. How are headings and bearings found?

**ANTICIPATED ANSWERS:**

- A1. Fifteen.
- A2. The shorter arc of the great circle joining them.
- A3. Using a compass.

---

**CONCLUSION**

---

**HOMEWORK / READING / PRACTICE**

Nil.

**METHOD OF EVALUATION**

This EO is assessed IAW A-CR-CCP-804/PG-001, *Proficiency Level Four Qualification Standard and Plan*, Chapter 3, Annex B, Aviation Subjects–Combined Assessment PC.

**CLOSING STATEMENT**

Future aviation training and instructional duties require knowledge of air navigation terms.

**INSTRUCTOR NOTES / REMARKS**

Cadets who are qualified Advanced Aviation may assist with this instruction.

---

**REFERENCES**

C3-116 ISBN 0-9680390-5-7 MacDonald, A. F., & Pepler, I. L. (2000). *From the ground up: Millennium edition*. Ottawa, ON: Aviation Publishers Co. Limited.

THIS PAGE INTENTIONALLY LEFT BLANK



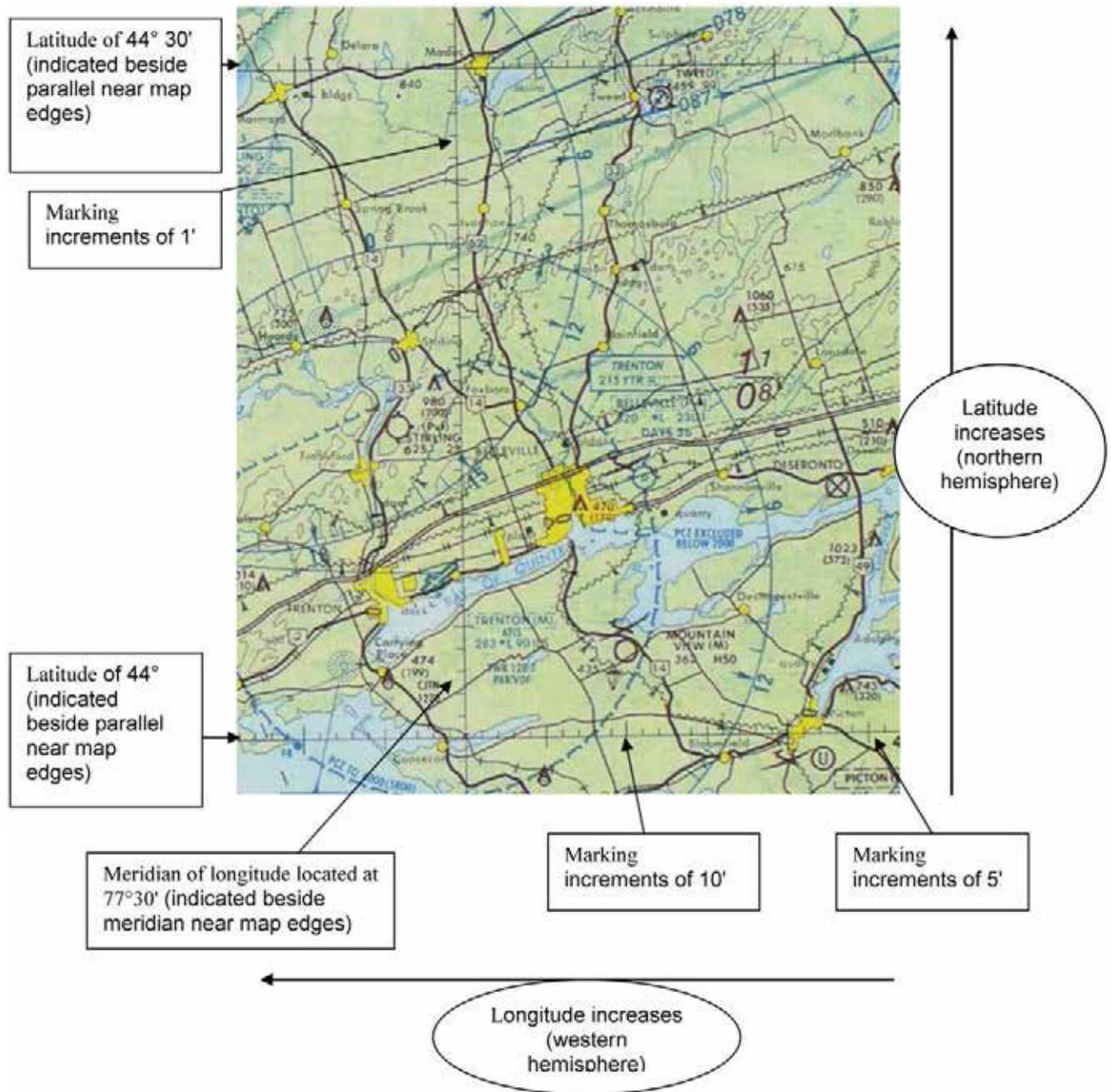

Figure A-1 Example of a VNC

Note. From *Toronto VFR Navigation Chart*, by Geomatics Canada, 2001, Ottawa, ON: Geomatics Canada Department of Natural Resources. Copyright 2001 by NAV CANADA and Her Majesty the Queen in Right of Canada.

THIS PAGE INTENTIONALLY LEFT BLANK

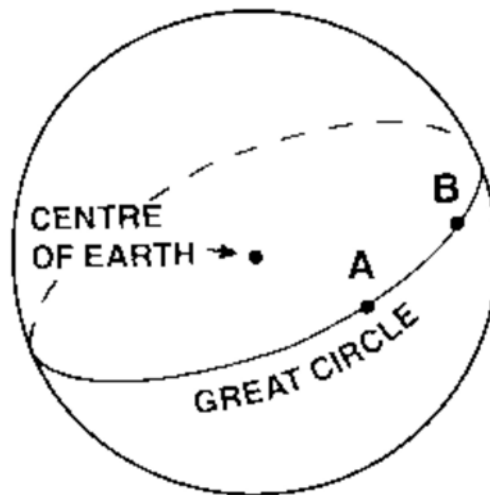

Figure B-1 Great Circle

*Note.* From *From the Ground Up: Millennium Edition* (p. 177), by A. F. MacDonald and I. L. Pepler, 2000, Ottawa, ON: Aviation Publishers Co. Limited. Copyright 2000 by Aviation Publishers Co. Limited.

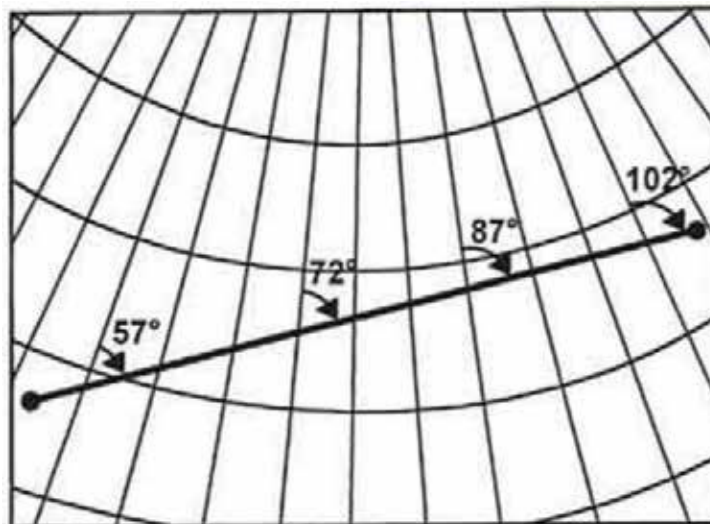

Figure B-2 Great Circle

*Note.* From "Navigation Basics", *Free Online Private Pilot Ground School*. Retrieved November 26, 2008, <http://www.free-online-private-pilot-ground-school.com/navigation-basics.html>

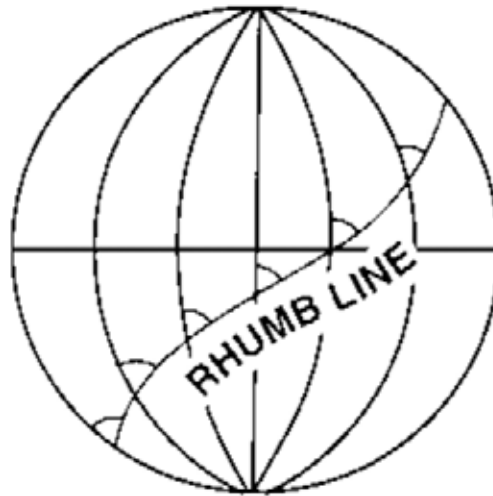

Figure B-3 Rhumb Line

*Note.* From *From the Ground Up: Millennium Edition* (p. 177), by A. F. MacDonald and I. L. Peppler, 2000, Ottawa, ON: Aviation Publishers Co. Limited. Copyright 2000 by Aviation Publishers Co. Limited.

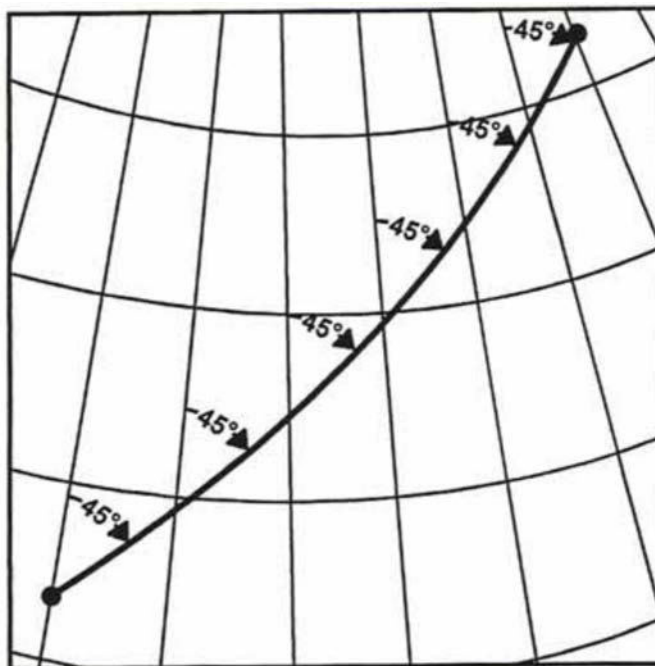

Figure B-4 Rhumb Line

*Note.* From "Navigation Basics", *Free Online Private Pilot Ground School*. Retrieved November 26, 2008, <http://www.free-online-private-pilot-ground-school.com/navigation-basics.html>



Figure B-5 Great Circle and Rhumb Line

Note. From "Flights", *Navworld*. Retrieved November 26, 2008, <http://www.navworld.com/navcerebrations/flights.htm>

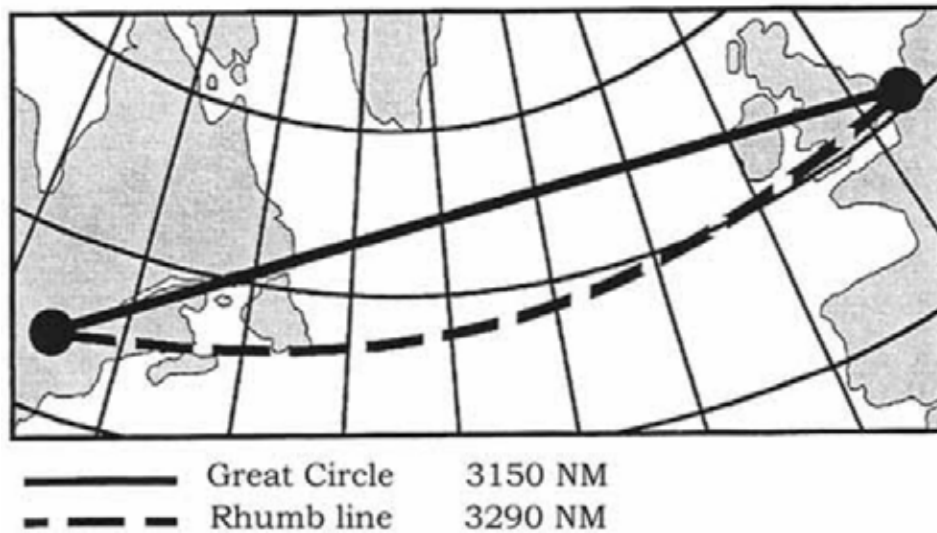

Figure B-6 Great Circle and Rhumb Line

Note. From "Navigation Basics", *Free Online Private Pilot Ground School*. Retrieved November 26, 2008, <http://www.free-online-private-pilot-ground-school.com/navigation-basics.html>



Figure B-7 Heading

*Note.* From *From the Ground Up: Millennium Edition* (p. 177), by A. F. MacDonald and I. L. Peppler, 2000, Ottawa, ON: Aviation Publishers Co. Limited. Copyright 2000 by Aviation Publishers Co. Limited.

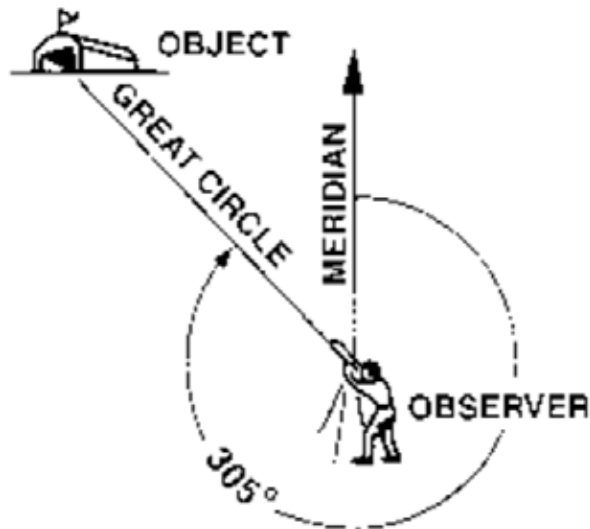

Figure B-8 Bearing

*Note.* From *From the Ground Up: Millennium Edition* (p. 177), by A. F. MacDonald and I. L. Peppler, 2000, Ottawa, ON: Aviation Publishers Co. Limited. Copyright 2000 by Aviation Publishers Co. Limited.

### Headings and Bearings Worksheet

#### Section 1 – Take the Heading of Each Aircraft



Section 2 – Take the Bearing of the Tower from the Aircraft

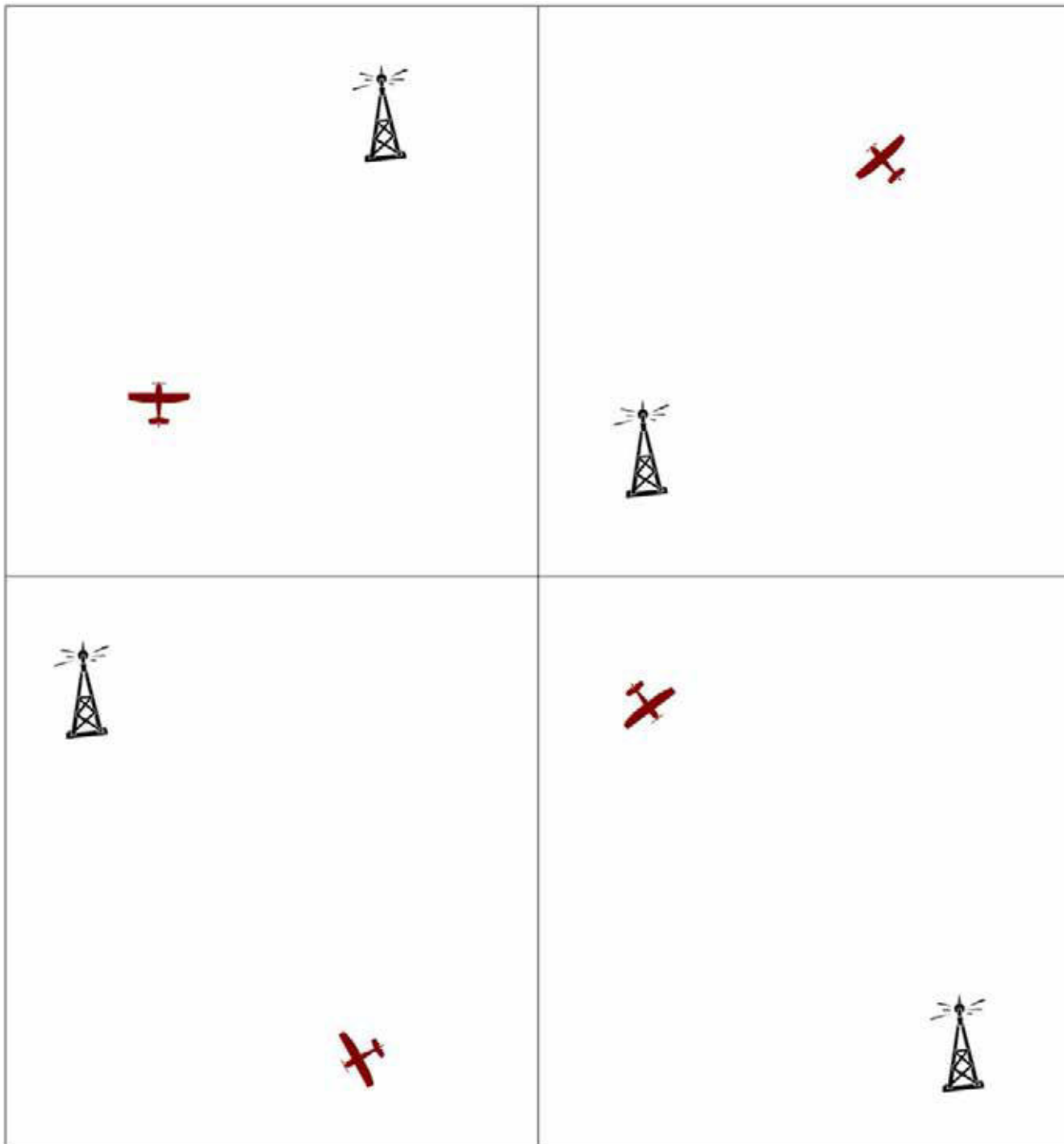





**ROYAL CANADIAN AIR CADETS  
PROFICIENCY LEVEL FOUR  
INSTRUCTIONAL GUIDE**



**SECTION 2**

**EO M437.02 – DESCRIBE THE MAGNETIC COMPASS**

---

Total Time:	30 min
-------------	--------

---

**PREPARATION**

---

**PRE-LESSON INSTRUCTIONS**

Resources needed for the delivery of this lesson are listed in the lesson specification located in A-CR-CCP-804/PG-001, *Proficiency Level Four Qualification Standard and Plan*, Chapter 4. Specific uses for said resources are identified throughout the instructional guide within the TP for which they are required.

Review the lesson content and become familiar with the material prior to delivering the lesson.

Prepare slides of the figures located at Attachment A.

Photocopy the homework assignment located at Attachment B for each cadet.

**PRE-LESSON ASSIGNMENT**

Nil.

**APPROACH**

An interactive lecture was chosen for this lesson to clarify, emphasize, and summarize the magnetic compass.

---

**INTRODUCTION**

---

**REVIEW**

Nil.

**OBJECTIVES**

By the end of this lesson the cadet shall be expected to describe the magnetic compass.

**IMPORTANCE**

It is important for the cadets to learn about the magnetic compass because the compass is a vital instrument used for navigation. The compass is often used as a reference for other instruments used in direction finding (such as the heading indicator). The cadets can apply this knowledge in a flight simulator and on a demonstration flight.

**Teaching Point 1****Describe the Earth's magnetism.**

Time: 5 min

Method: Interactive Lecture

**THE EARTH'S MAGNETISM**

The Earth is a giant magnet that has a north and south pole. There are lines of force generated by currents of molten iron that flow within the Earth. The lines of force flow between the poles, creating a magnetic field that surrounds the Earth. The compass needle is affected by the lines of force, causing the magnetic needle to point to magnetic north.

**Points of a Compass Rose**

Show the slide of Figure A-1 to the cadets.

The main cardinal points are north, south, east, and west. The inter-cardinal points are northeast, southeast, southwest, and northwest.

**CONFIRMATION OF TEACHING POINT 1****QUESTIONS:**

- Q1. Where does the magnetic needle point?
- Q2. What cardinal point does a bearing of 270 degrees represent?
- Q3. What is your heading (in degrees) if you are flying northeast?

**ANTICIPATED ANSWERS:**

- A1. Magnetic north.
- A2. West.
- A3. 45 degrees.

**Teaching Point 2****Describe the main parts of the magnetic compass.**

Time: 5 min

Method: Interactive Lecture

**MAIN PARTS OF THE MAGNETIC COMPASS**

Show the slide of Figure A-2 to the cadets.

Point out the parts of a magnetic compass using the examples of magnetic compasses.

**Lubber line.** The lubber line is a painted white line that indicates the direction the airplane is heading. It is in line with or parallel to the longitudinal axis of the airplane. It is at this location that the compass card is read.

**Compass card.** The compass card contains the numbers. It is attached to the pivot and moves within the compass bowl. The compass card is read at the lubber line through a window.

**Compass bowl.** The compass bowl encompasses the entire compass assembly, including the liquid. The compass bowl is made of brass which is a non-magnetic material.

**Pivot.** The pivot allows the compass card to rotate freely.

**Magnetic needle.** The magnetic needle always points to magnetic north.

**Liquid.** The compass bowl is filled with liquid to lubricate the pivot, reduce the weight of the compass card and magnets, and limit movement that may be caused by turbulence. The liquid is either alcohol or white kerosene because they are transparent and have a low freezing point and a high boiling point.

## CONFIRMATION OF TEACHING POINT 2

### QUESTIONS:

- Q1. What does the lubber line indicate?
- Q2. What part of the compass contains the numbers that are read?
- Q3. What liquids are used in the compass bowl?

### ANTICIPATED ANSWERS:

- A1. The direction the airplane is heading.
- A2. The compass card.
- A3. Alcohol or white kerosene.

## Teaching Point 3

**Describe variation.**

Time: 5 min

Method: Interactive Lecture

## VARIATION

True north and magnetic north do not have the same location. The two poles can be located far apart because magnetic north is continuously moving at a very slow rate. This is a significant concern for navigation because geographical coordinates are based on true or geographic north whereas a magnetic compass points to magnetic north.



Show the slide of Figure A-3 to the cadets.

**Variation.** Variation is the angle between true north and magnetic north. It is also known as magnetic declination. This angle is taken into consideration during flight planning.

**Agonic lines.** Agonic lines join places of zero magnetic variation. This is to say that both the true north and magnetic north lie in a straight line relative to these places.

**Isogonic lines.** Isogonic lines join places of equal magnetic variation. If an observer were to move along this invisible line, the angle between true and magnetic north would remain the same.



Aeronautical navigation charts use true north and display variation information. Pilots must convert the true headings to magnetic headings in order to navigate using the charts and magnetic compass.

The following rhymes can help pilots remember how to apply variation to true headings:

- "Variation West, Magnetic Best", and
- "Variation East, Magnetic Least".

In other words, ADD westerly variation to a true heading to calculate the magnetic heading. SUBTRACT easterly variation from a true heading to calculate the magnetic heading.

---

### CONFIRMATION OF TEACHING POINT 3

#### QUESTIONS:

- Q1. What is variation?
- Q2. What are isogonic lines?
- Q3. How is a magnetic heading calculated?

#### ANTICIPATED ANSWERS:

- A1. The angle between true north and magnetic north.
- A2. Isogonic lines join places of equal magnetic variation.
- A3. By adding westerly variation (subtracting easterly variation) to (from) the true heading.

---

### Teaching Point 4

**Describe compass errors.**

Time: 10 min

Method: Interactive Lecture

---

### Deviation

The magnetic compass is affected by anything metal that is in close proximity to it. When mounted in an aircraft, it is affected by the surrounding metal in the aircraft's frame and engine, as well as electrical equipment. The compass does not point to magnetic north, but is deflected slightly by the magnetic fields associated with the surrounding metal. The direction that the magnetic needle will point when affected by the running engine and working electrical equipment is unique to the aircraft. It is referred to as compass north. The angle between magnetic north and compass north is deviation.



Demonstrate deviation by placing a compass near a laptop computer or other electrical device.

Since deviation cannot be eliminated, the amount of deviation on a given heading is determined so that a pilot can compensate for this compass error. This occurs by swinging the compass. The aircraft is lined up on a

known magnetic heading with its engine running and all electrical equipment working. The direction is read from the compass and compared to the known magnetic heading. After this is taken on many headings, a compass correction card is prepared and placed in the aircraft.



Show the slide of Figure A-4 to the cadets.



Deviation must be added to or subtracted from the magnetic heading to calculate the compass heading.

When the magnetic heading is between the headings listed on the compass correction card, interpolate (estimate) the amount of deviation by using the two nearest magnetic headings that are listed.

### Magnetic Dip

The magnetic lines of force of the Earth's magnetic field are horizontal at the equator, but bend down into the poles. This causes the north-seeking end of the needle to dip towards the ground. This error is more pronounced the closer the compass is to the poles.

Magnetic dip can be reduced, but not eliminated, by the design of the compass.

### Northerly Turning Error

During a turn, centripetal and centrifugal forces combine with the inertial influence of the liquid in the compass bowl to affect the movement of the compass needle. This error is most apparent on north and south headings. The amount of the error is greatest over the poles and the least over the equator.



On turns from north, northerly turning error causes the compass to lag.

On turns from south, northerly turning error causes the compass to lead.

### Acceleration and Deceleration Errors

Acceleration or deceleration of the aircraft affects the magnetic compass and the inertia causes a turning moment when the aircraft is on an east or west heading. Once the airspeed has stabilized, the compass will again read correctly.



Show the slide of Figure A-5 to the cadets.



On east and west headings:

- acceleration causes the compass to register a turn toward north, and
- deceleration causes the compass to register a turn toward south.

---

## CONFIRMATION OF TEACHING POINT 4

### QUESTIONS:

- Q1. For what does a compass card indicate corrections?
- Q2. What does a turn from the north cause a compass to do?
- Q3. On what headings do acceleration and deceleration cause the compass to register a turn?

### ANTICIPATED ANSWERS:

- A1. Deviation.
- A2. Lag.
- A3. East and west.

---

## END OF LESSON CONFIRMATION

The cadets' completion of the homework assignment will serve as the confirmation of this lesson.

---

## CONCLUSION

---

## HOMEWORK / READING / PRACTICE

Have the cadets complete the Magnetic Headings Worksheet located at Attachment B. Use the answer key located at Attachment C to review their answers.

## METHOD OF EVALUATION

This EO is assessed IAW A-CR-CCP-804/PG-001, *Proficiency Level Four Qualification Standard and Plan*, Chapter 3, Annex B, Aviation Subjects–Combined Assessment PC.

## CLOSING STATEMENT

To use a magnetic compass, the underlying principles must be understood. A compass is a common instrument in aviation and can act as a reference for setting other instruments. Magnetic compasses are useful not only in aviation but also on the ground and on the water.

## INSTRUCTOR NOTES / REMARKS

Cadets who are qualified Advanced Aviation may assist with this instruction.

---

## REFERENCES

C3-116 ISBN 0-9680390-5-7 MacDonald, A. F., & Peppler, I. L. (2000). *From the ground up: Millennium edition*. Ottawa, ON: Aviation Publishers Co. Limited.

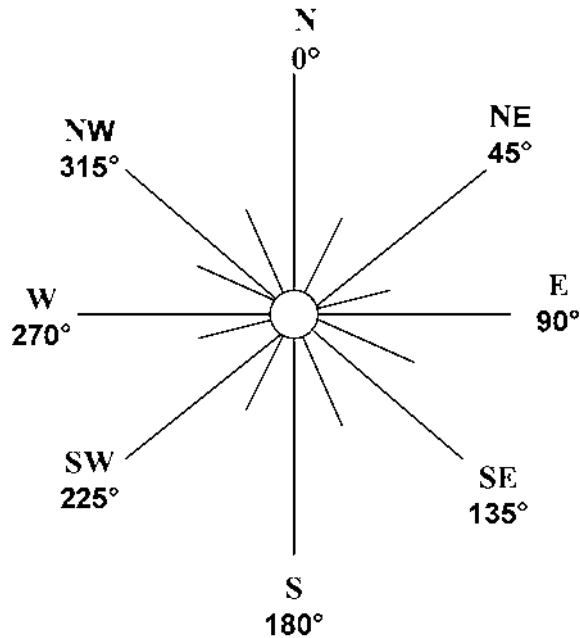

Figure A-1 Points on a Compass Rose

*Note.* Created by Director Cadets 3, 2007, Ottawa, ON: Department of National Defence.

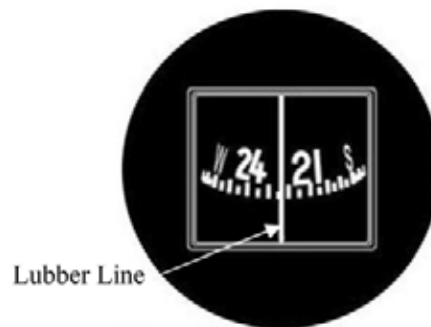

Figure A-2 Lubber Line

*Note.* From "Magnetic Compass", by North American Powered Parachute Federation, 2001, *Flight Instruments*, Copyright 2001 by North American Powered Parachute Federation. Retrieved November 8, 2007, from [http://www.nappf.com/nappf\\_flight\\_instruments\\_files/image008.jpg](http://www.nappf.com/nappf_flight_instruments_files/image008.jpg)

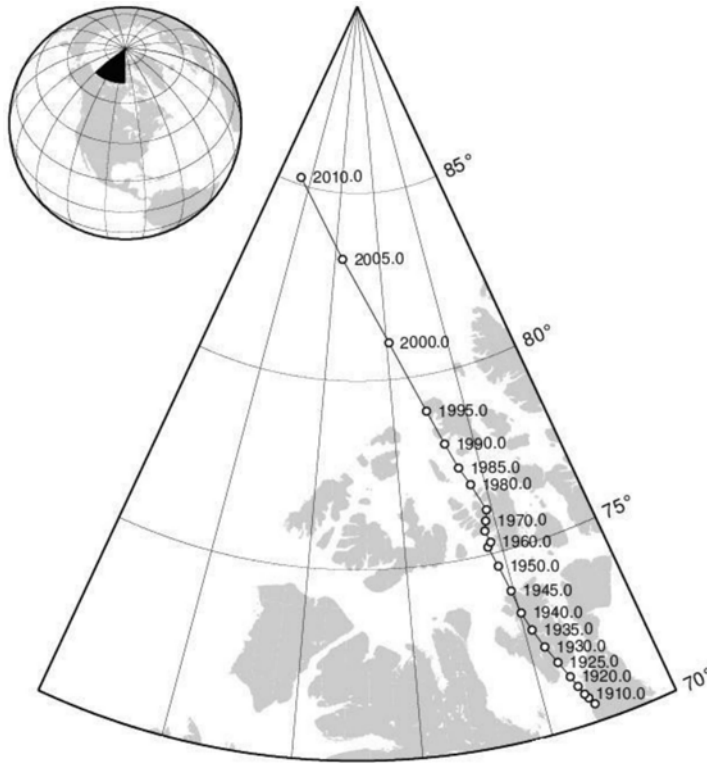

Figure A-3 Location of the Magnetic North Pole

Note. From "Locations of the North Magnetic Pole from IGRF-10", by K. Korhonen, *Helsinki University of Technology*. Retrieved November 8, 2007, from <http://users.tkk.fi/~kkorhon1/nmplocs.png>

For	0°	30°	60°	90°	120°	150°	180°	210°	240°	270°	300°	330°
Steer	359°	30°	60°	88°	120°	152°	183°	212°	240°	268°	300°	329°

Figure A-4 Compass Correction Card

Note. Created by Director Cadets 3, 2008, Ottawa, ON: Department of National Defence.

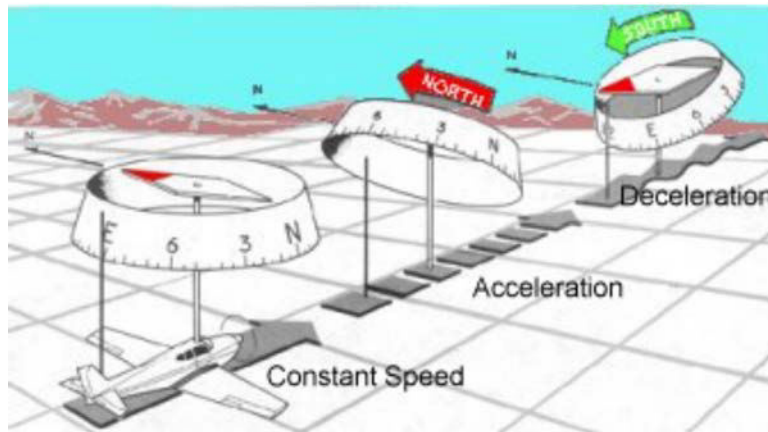

Figure A-5 Acceleration and Deceleration Errors

Note. From "Magnetism and the Magnetic Compass", by *Pilot's Web*. Retrieved November 8, 2007, from <http://pilotsweb.com/navigate/art/accel.jpg>



### MAGNETIC HEADINGS WORKSHEET

Fill in the missing values.

	Variation	True Heading	Magnetic Heading
1.	8° west	120°	_____
2.	2° east	270°	_____
3.	11° east	010°	_____
4.	15° west	350°	_____
5.	22° east	180°	_____
6.	_____	090°	101°
7.	_____	085°	080°
8.	_____	359°	005°
9.	_____	254°	266°
10.	_____	122°	118°
11.	9° east	_____	113°
12.	3° west	_____	357°
13.	15° west	_____	345°
14.	12° east	_____	124°
15.	2° west	_____	180°

### Sample Compass Correction Card

For	0°	30°	60°	90°	120°	150°	180°	210°	240°	270°	300°	330°
Steer	359°	30°	60°	88°	120°	152°	183°	212°	240°	268°	300°	329°

Fill in the missing values.

	Magnetic Heading	Compass Heading
1.	020°	_____
2.	161°	_____
3.	345°	_____
4.	_____	080°
5.	_____	215°

THIS PAGE INTENTIONALLY LEFT BLANK

**MAGNETIC HEADINGS ANSWER KEY**

Fill in the missing values.

	Variation	True Heading	Magnetic Heading
1.	8° west	120°	<b>128°</b>
2.	2° east	270°	<b>268°</b>
3.	11° east	010°	<b>359°</b>
4.	15° west	350°	<b>005°</b>
5.	22° east	180°	<b>158°</b>
6.	<b>11° west</b>	090°	101°
7.	<b>5° east</b>	085°	080°
8.	<b>6° west</b>	359°	005°
9.	<b>12° west</b>	254°	266°
10.	<b>4° east</b>	122°	118°
11.	9° east	<b>122°</b>	113°
12.	3° west	<b>354°</b>	357°
13.	15° west	<b>330°</b>	345°
14.	12° east	<b>136°</b>	124°
15.	2° west	<b>178°</b>	180°

**Sample Compass Correction Card**

For	0°	30°	60°	90°	120°	150°	180°	210°	240°	270°	300°	330°
Steer	359°	30°	60°	88°	120°	152°	183°	212°	240°	268°	300°	329°

Fill in the missing values.

	Magnetic Heading	Compass Heading
1.	020°	<b>020°</b>
2.	161°	<b>163°</b>
3.	345°	<b>344°</b>
4.	<b>082°</b>	080°
5.	<b>213°</b>	215°

THIS PAGE INTENTIONALLY LEFT BLANK



**ROYAL CANADIAN AIR CADETS**  
**PROFICIENCY LEVEL FOUR**  
**INSTRUCTIONAL GUIDE**



**SECTION 3**

**EO C437.01 – SOLVE NAVIGATION PROBLEMS WITH A MANUAL FLIGHT COMPUTER**

---

Total Time:	60 min
-------------	--------

---

**PREPARATION**

---

**PRE-LESSON INSTRUCTIONS**

Resources needed for the delivery of this lesson are listed in the lesson specification located in A-CR-CCP-804/PG-001, *Proficiency Level Four Qualification Standard and Plan*, Chapter 4. Specific uses for said resources are identified throughout the instructional guide within the TP for which they are required.

Review the lesson content and become familiar with the material prior to delivering the lesson.

Prepare slides of the figures located at Attachment A.

Photocopy the Navigation Problems Worksheet located at Attachment B for each cadet.

Assistant instructors may be required for this lesson.

**PRE-LESSON ASSIGNMENT**

Nil.

**APPROACH**

A demonstration and performance was chosen for this lesson as it allows the instructor to explain and demonstrate solving navigation problems with a manual flight computer while providing an opportunity for the cadets to practice this skill under supervision.

---

**INTRODUCTION**

---

**REVIEW**

Nil.

**OBJECTIVES**

By the end of this lesson the cadet shall have solved navigation problems with a manual flight computer.

**IMPORTANCE**

It is important for cadets to be able to solve navigation problems with a manual flight computer as it is an important skill that is required for flight planning and en route navigation. Solving navigation problems provides skills for potential instructional duties and is part of the fundamentals that cadets pursuing future aviation training will require.



For this lesson, it is recommended that the instruction take the following format:

1. Explain and demonstrate the technique to use the manual flight computer while the cadets observe.
2. Explain and demonstrate each step required to complete the skill. Monitor cadets as they imitate each step.
3. Monitor the cadets' performance as they practice using the manual flight computer to solve navigation problems.

Note: Assistant instructors may be used to monitor the cadets' performance.

### Teaching Point 1

**Demonstrate how to use a manual flight computer to convert units of measure and have the cadets practice converting units of measure.**

Time: 25 min

Method: Demonstration and Performance

### MANUAL FLIGHT COMPUTER

Navigation calculations are simplified by the use of a flight computer. Most manual flight computers consist of two sides: a circular slide rule and a wind side.



Show the slide of Figure A-1 to the cadets.



The instructions for using a manual flight computer are often printed directly on the flight computer.

### Circular Slide Rule

The circular slide rule can be used to solve any problem of multiplication, division, or proportion. There are three scales printed on the circular slide rule. The outer scale is fixed to the computer. The two inner scales are printed together on a disc that may be rotated to any position opposite the outer scale.



Show the slide of Figure A-2 to the cadets.

The outer scale represents miles, gallons, true airspeed and corrected altitude. The inner scale represents time in minutes, calibrated airspeed, and calibrated altitude. The third scale represents time in hours and minutes.

The figures on the circular slide rule may represent any proportion or multiple of 10. For example, 10 on the outer scale may represent 1, 10, or 100; 45 may represent 4.5, 45, or 450.

## CONVERTING UNITS OF MEASURE

One of the most common types of calculations a pilot has to make is converting from one unit of measure to another. Fuel is sold by the litre, but fuel quantities and consumption are usually specified in the aircraft manual in gallons. Wind speeds are reported in knots, but the airspeed indicator (ASI) may be in statute miles per hour.

Using the circular slide rule for conversion calculations is a simple process. Rotate the inner scale to the correct position, locate the original quantity / measure on the outer scale, and read the converted quantity / measure from the inner scale, opposite to the appropriate marking.

### Convert Between Nautical and Statute Miles

To convert between nautical and statute miles:

1. Rotate the inner scale until the known number of miles is under the appropriate index (NAUT or STAT).
2. Read the converted number of miles under the other index.



For example, to convert 90 nautical miles to statute miles:

1. Rotate the inner scale until 90 is under the nautical miles index.
2. Read the number of statute miles under the statute miles index (104 statute miles).

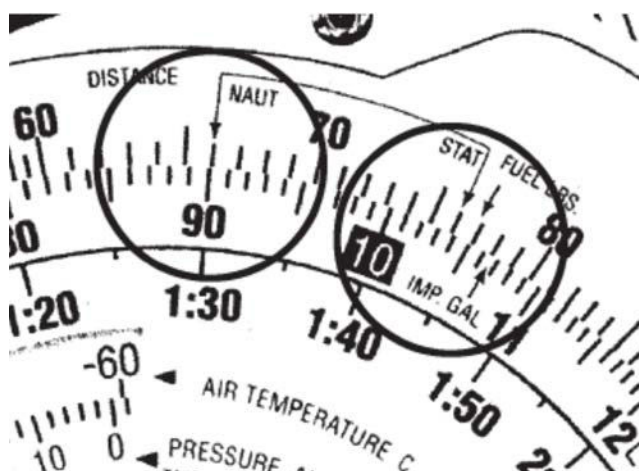



Figure 1 Nautical and Statute Mile Indexes

*Note.* From "Air Classics E6-B Flight Computer Instructions", *Aviation Supplies and Academics, Inc.* Retrieved November 26, 2008, from [http://www.asa2fly.com/files/support/E6B\\_Manual.pdf](http://www.asa2fly.com/files/support/E6B_Manual.pdf)

### Convert Between Miles and Kilometres

To convert between miles and kilometres:

1. Rotate the inner scale until the known number is under the appropriate index (NAUT, STAT, or KM).
2. Read the converted number under the desired index.



For example, to convert 115 statute miles to kilometres:

1. Rotate the inner scale until 115 is under the statute miles index.
2. Read the number of kilometres under the kilometres index (185 km).



Figure 2 Statute Mile and Kilometre Indexes

Note. From "Air Classics E6-B Flight Computer Instructions", *Aviation Supplies and Academics, Inc.* Retrieved November 26, 2008, from [http://www.asa2fly.com/files/support/E6B\\_Manual.pdf](http://www.asa2fly.com/files/support/E6B_Manual.pdf)

### Convert Between Imperial and US Gallons

To convert between imperial and US gallons:

1. Rotate the inner scale until the imperial and US gallon indexes are aligned.
2. Locate the known quantity (outer scale for imperial gallons and inner scale for US gallons) and read the desired quantity on the opposite scale.



For example, to convert 55 imperial gallons to US gallons:

1. Rotate the inner scale until the imperial and US gallon indexes are aligned.
2. Locate 55 on the outer scale and read the quantity of US gallons on the inner scale (66 US gallons).



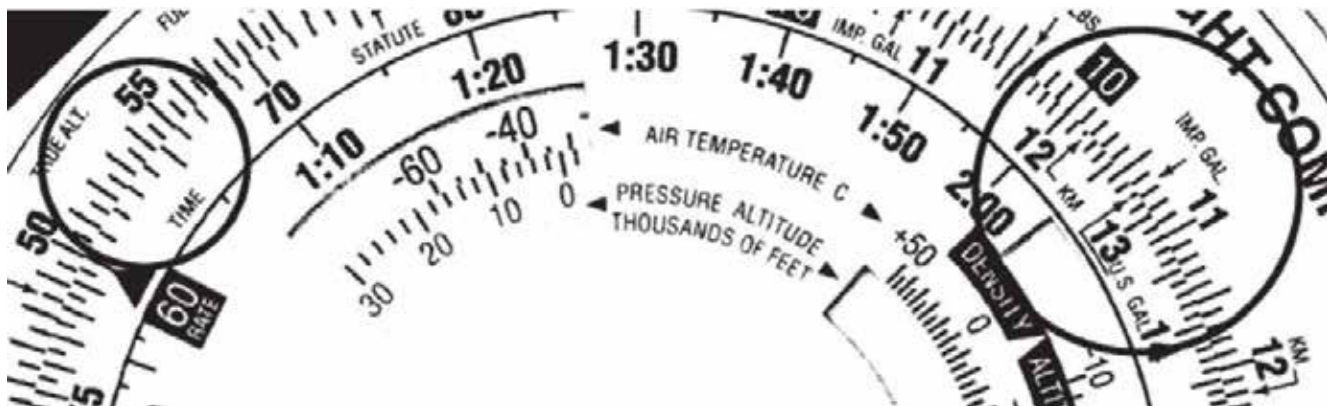

Figure 3 US and Imperial Gallon Indexes

Note. From "Air Classics E6-B Flight Computer Instructions", *Aviation Supplies and Academics, Inc.* Retrieved November 26, 2008, from [http://www.asa2fly.com/files/support/E6B\\_Manual.pdf](http://www.asa2fly.com/files/support/E6B_Manual.pdf)

### Convert Between Gallons and Litres

To convert between gallons and litres:

1. Rotate the inner scale until the litres index is aligned with the appropriate gallon index.
2. Locate the known quantity and read the desired quantity on the opposite scale.



For example, to convert 100 L to US gallons:

1. Rotate the inner scale until the litres index is aligned with the US gallon index.
2. Locate 100 on the outer scale and read the quantity of US gallons on the inner scale (26 US gallons).

### Convert Between Pounds and Kilograms

To convert between pounds and kilograms:

1. Rotate the inner scale until the pounds index is aligned with the kilograms index.
2. Locate the known quantity and read the desired quantity on the opposite scale.



For example, to convert 100 pounds to kilograms:

1. Rotate the inner scale until the pounds index is aligned with the kilograms index.
2. Locate 100 on the outer scale and read the quantity of kilograms on the inner scale (45 kg).

---

## ACTIVITY

Time: 10 min

### OBJECTIVE

The objective of this activity is to have the cadets practice converting units of measure using a manual flight computer.

### RESOURCES

- Pen / pencil,
- Manual flight computer,
- Navigation Problems Worksheet located at Attachment B, and
- Navigation Problems Answer Key located at Attachment C.

### ACTIVITY LAYOUT

Nil.

### ACTIVITY INSTRUCTIONS

1. Distribute a manual flight computer and a Navigation Problems Worksheet to each cadet.
2. Have the cadets complete Part 1 of the worksheet using the manual flight computer.
3. Review the answers using the answer key located at Attachment C.

### SAFETY

Nil.

---

### CONFIRMATION OF TEACHING POINT 1

The cadets' participation in the activity will serve as the confirmation of this TP.

---

### Teaching Point 2

**Demonstrate how to use a manual flight computer to calculate speed, distance, and time and have the cadets practice calculating speed, distance, and time.**

Time: 25 min

Method: Demonstration and Performance

---

### SPEED, DISTANCE, AND TIME PROBLEMS

The rate arrow on the disk is always set to indicate a value per hour on the outer scale. There are three basic types of speed-time-distance problems. In two types of problems the speed is known, in the third, the speed is the unknown.



When solving speed, distance, and time problems, the units have to agree. For example, if the speed is in knots, the distance has to be in nautical miles and the time in hours.

If the units do not agree, use the circular slide rule to perform the required conversions to make the units agree before attempting to solve the problem.

### Calculating Time (Speed and Distance are Known)

To calculate time when speed and distance are known:

1. Rotate the inner scale until the rate arrow is opposite the speed.
2. Locate the distance on the outer scale.
3. Read the time from the inner scale, opposite the distance.



For example, to calculate the time en route if the speed is 150 knots and the distance is 245 nautical miles:

1. Rotate the inner scale until the rate arrow is opposite 150.
2. Locate 245 on the outer scale.
3. Read the time en route from the inner scale, opposite 245 (1 hour and 38 minutes).

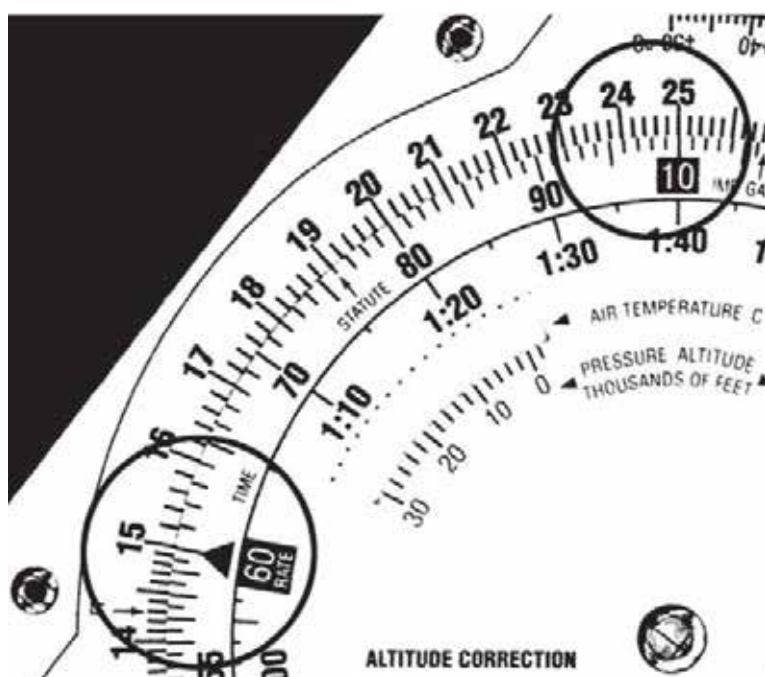

Figure 4 Rate Arrow, Speed, Distance, and Time

Note. From "Air Classics E6-B Flight Computer Instructions", *Aviation Supplies and Academics, Inc.* Retrieved November 26, 2008, from [http://www.asa2fly.com/files/support/E6B\\_Manual.pdf](http://www.asa2fly.com/files/support/E6B_Manual.pdf)



For example, to calculate the time en route if the speed is 120 knots and the distance is 100 statute miles:

1. Convert the distance to nautical miles (87).
2. Rotate the inner scale until the rate arrow is opposite 120.
3. Locate 87 on the outer scale.
4. Read the time en route from the inner scale, opposite 87 (44 minutes).



When calculating time en route, use the aircraft's groundspeed, not the airspeed.

**Calculating Distance (Speed and Time are Known)**

To calculate distance when speed and time are known:

1. Rotate the inner scale until the rate arrow is opposite the speed.
2. Locate the time on the inner scale.
3. Read the distance from the outer scale, opposite the time.



For example, to calculate the distance if the speed is 125 knots and the time en route is 4.5 hours:

1. Rotate the inner scale until the rate arrow is opposite 125.
2. Locate 4:30 on the inner scale.
3. Read the distance from the outer scale, opposite 4:30 (564 nautical miles).

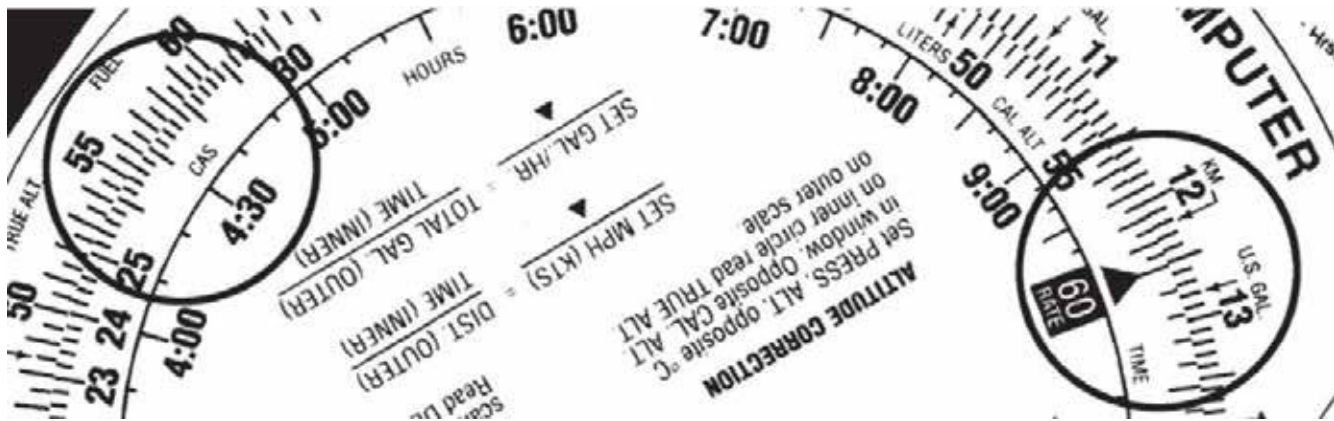

Figure 5 Rate Arrow, Speed, Distance, and Time

*Note.* From "Air Classics E6-B Flight Computer Instructions", *Aviation Supplies and Academics, Inc.* Retrieved November 26, 2008, from [http://www.asa2fly.com/files/support/E6B\\_Manual.pdf](http://www.asa2fly.com/files/support/E6B_Manual.pdf)



When calculating distance, use the aircraft's groundspeed, not the airspeed.

**Calculating Speed (Distance and Time are Known)**

To calculate speed when distance and time are known:

1. Rotate the inner scale until the distance is opposite the time.
2. Locate the rate arrow.
3. Read the speed from the outer scale, opposite the rate arrow.



For example, to calculate the speed if the distance is 26 nautical miles and the time en route is 13 minutes:

1. Rotate the inner scale until 26 is opposite 13.
2. Locate the rate arrow.
3. Read the speed from the outer scale, opposite the rate arrow (120 knots).

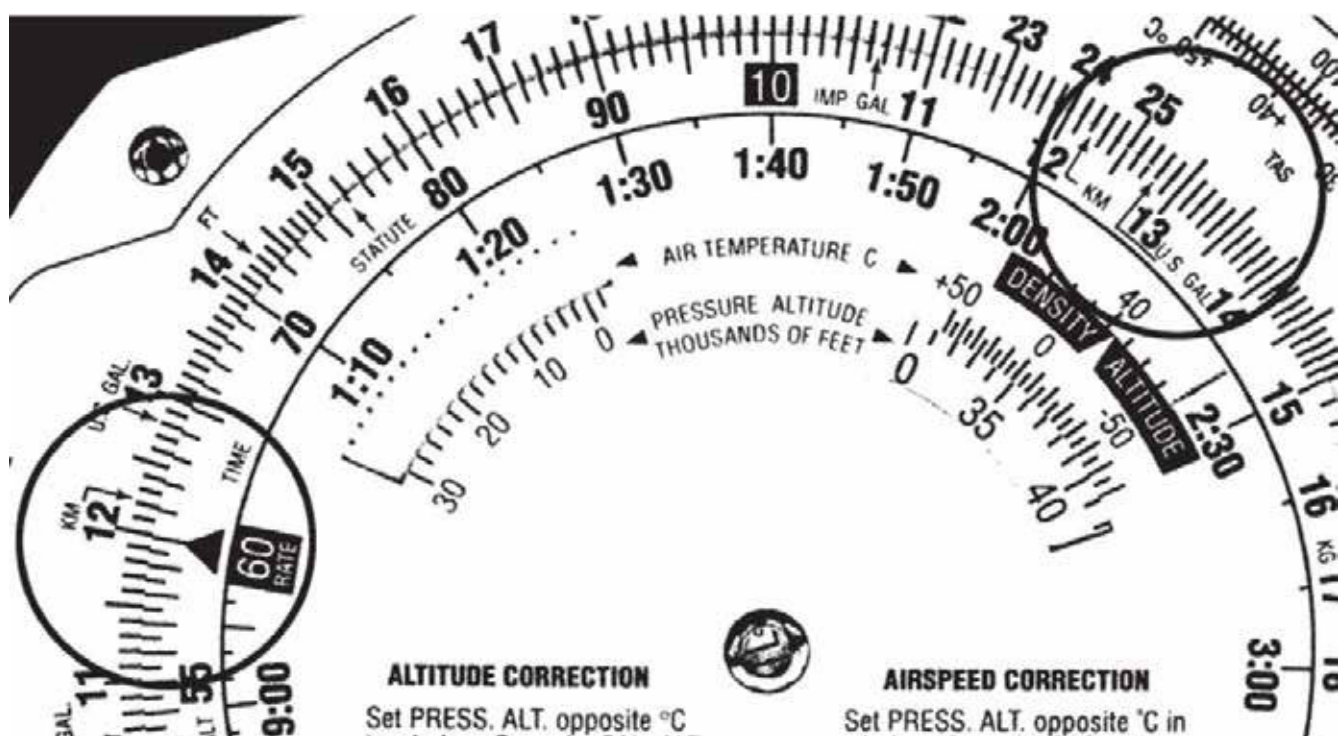

Figure 6 Rate Arrow, Speed, Distance, and Time

Note. From "Air Classics E6-B Flight Computer Instructions", *Aviation Supplies and Academics, Inc.* Retrieved November 26, 2008, from [http://www.asa2fly.com/files/support/E6B\\_Manual.pdf](http://www.asa2fly.com/files/support/E6B_Manual.pdf)



When calculating speed from distance and time, it is the groundspeed that is being calculated, not the airspeed.

## ACTIVITY

Time: 10 min

### OBJECTIVE

The objective of this activity is to have the cadets practice calculating speed, distance, and time using a manual flight computer.

### RESOURCES

- Pen / pencil,
- Manual flight computer,

- Navigation Problems Worksheet located at Attachment B, and
- Navigation Problems Answer Key located at Attachment C.

### **ACTIVITY LAYOUT**

Nil.

### **ACTIVITY INSTRUCTIONS**

1. Have the cadets complete Part 2 of the worksheet using the manual flight computer.
2. Review the answers using the answer key located at Attachment C.

### **SAFETY**

Nil.

---

### **CONFIRMATION OF TEACHING POINT 2**

The cadets' participation in the activity will serve as the confirmation of this TP.

---

### **END OF LESSON CONFIRMATION**

The cadets' completion of the Navigation Problems Worksheet will serve as the confirmation of this lesson.

---

### **CONCLUSION**

---

### **HOMEWORK / READING / PRACTICE**

Additional time may be required for the cadets to complete the worksheet.

### **METHOD OF EVALUATION**

Nil.

### **CLOSING STATEMENT**

Flight planning and navigation relies on being able to solve navigation problems. Being able to use a manual flight computer makes solving navigation problems faster and easier.

### **INSTRUCTOR NOTES / REMARKS**

Assistant instructors may be required for this lesson.

Cadets who are qualified Advanced Aviation may assist with this instruction.

---

### **REFERENCES**

C3-116 ISBN 0-9680390-5-7 MacDonald, A. F., & Peppler, I. L. (2000). *From the ground up: Millennium edition*. Ottawa, ON: Aviation Publishers Co. Limited.



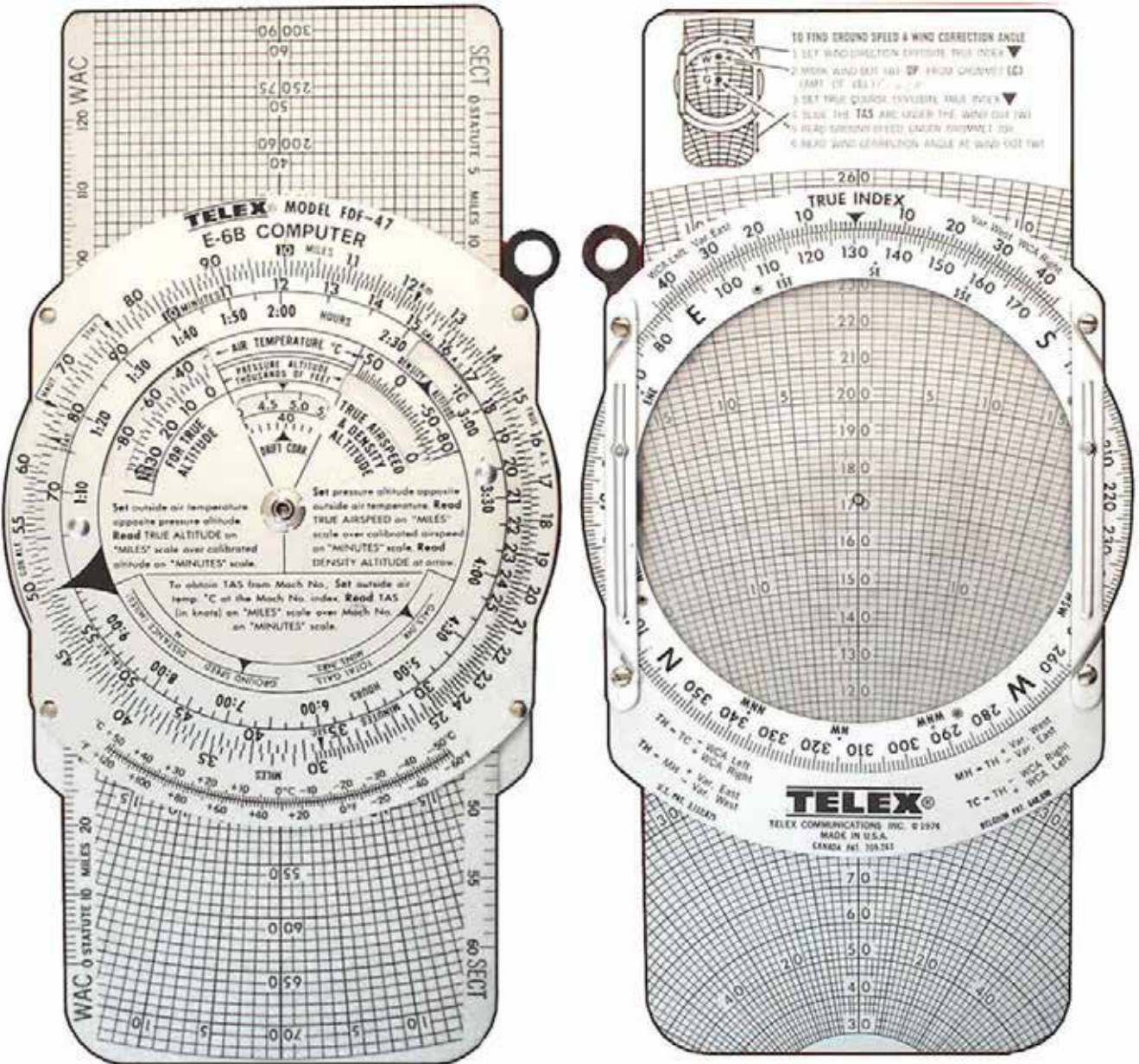

Figure A-1 E6B Manual Flight Computer

Note. From "Slide Rule Catalog", *Dutch Circle of Slide Rule Collectors*. Retrieved November 26, 2008, from <http://www.rekeninstrumenten.nl/pages%20and%20pictures/25261.jpg>

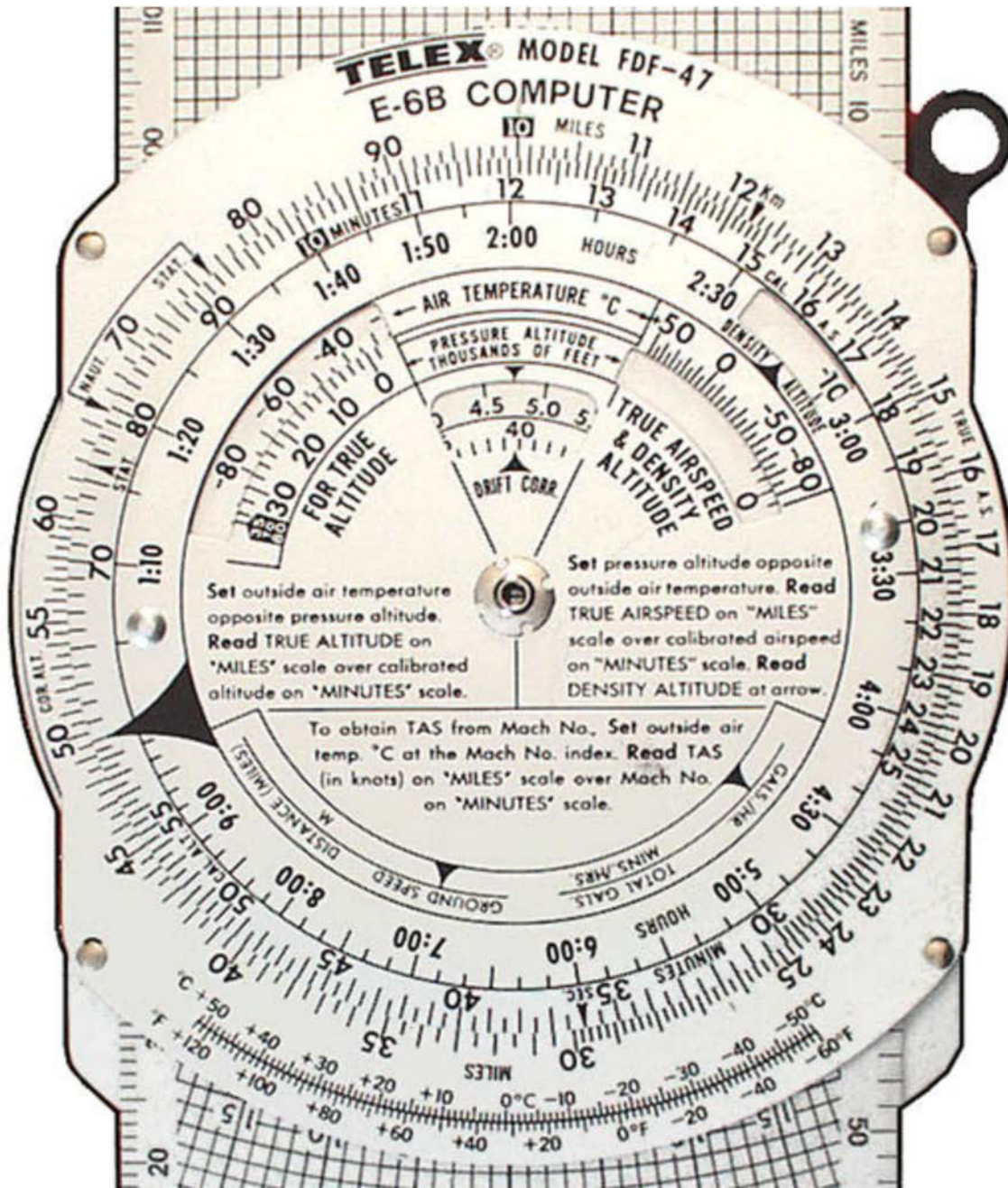

Figure A-2 E6B Circular Slide Rule

Note. From "Slide Rule Catalog", *Dutch Circle of Slide Rule Collectors*. Retrieved November 26, 2008, from <http://www.rekeninstrumenten.nl/pages%20and%20pictures/25261.jpg>



### Navigation Problems Worksheet

#### Part 1

Convert	To	Convert	To
123 nautical miles	_____ statute miles	23 nautical miles	_____ statute miles
99 statute miles	_____ nautical miles	1000 statute miles	_____ nautical miles
400 statute miles	_____ km	85 statute miles	_____ km
25 km	_____ statute miles	110 km	_____ statute miles
156 km	_____ nautical miles	93 km	_____ nautical miles
225 nautical miles	_____ km	48 nautical miles	_____ km
10 US gallons	_____ gallons	150 US gallons	_____ gallons
150 US gallons	_____ L	35 US gallons	_____ L
35 gallons	_____ US gallons	10 gallons	_____ US gallons
48 gallons	_____ L	225 gallons	_____ L
93 L	_____ gallons	156 L	_____ gallons
110 L	_____ US gallons	25 L	_____ US gallons
55 pounds	_____ kg	400 pounds	_____ kg
85 kg	_____ pounds	99 kg	_____ pounds
1000 feet	_____ m	123 feet	_____ m
23 m	_____ feet	55 m	_____ feet

#### Part 2

Calculate the missing values.		
Speed	Distance	Time
130 knots	100 nautical miles	_____
85 knots	_____	2.5 hours
_____	250 nautical miles	4 hours 15 minutes
_____	25 nautical miles	5 minutes
65 knots	200 statute miles	_____
78 miles per hour	55 nautical miles	_____
330 km/h	300 km	_____
95 km/h	45 nautical miles	_____
_____	1000 km	320 minutes
_____	55 nautical miles	2 minutes
122 miles per hour	_____	1.3 hours
101 knots	_____	45 minutes
150 knots	5525 m	_____

THIS PAGE INTENTIONALLY LEFT BLANK

### Navigation Problems Answer Key

#### Part 1

Convert	To	Convert	To
123 nautical miles	<u>142</u> statute miles	23 nautical miles	<u>26</u> statute miles
99 statute miles	<u>86</u> nautical miles	1000 statute miles	<u>869</u> nautical miles
400 statute miles	<u>644</u> km	85 statute miles	<u>137</u> km
25 km	<u>16</u> statute miles	110 km	<u>68</u> statute miles
156 km	<u>84</u> nautical miles	93 km	<u>50</u> nautical miles
225 nautical miles	<u>417</u> km	48 nautical miles	<u>89</u> km
10 US gallons	<u>8</u> gallons	150 US gallons	<u>125</u> gallons
150 US gallons	<u>568</u> L	35 US gallons	<u>132</u> L
35 gallons	<u>42</u> US gallons	10 gallons	<u>12</u> US gallons
48 gallons	<u>218</u> L	225 gallons	<u>1023</u> L
93 L	<u>20</u> gallons	156 L	<u>34</u> gallons
110 L	<u>29</u> US gallons	25 L	<u>7</u> US gallons
55 pounds	<u>25</u> kg	400 pounds	<u>181</u> kg
85 kg	<u>187</u> pounds	99 kg	<u>218</u> pounds
1000 feet	<u>305</u> m	123 feet	<u>37</u> m
23 m	<u>75</u> feet	55 m	<u>180</u> feet

#### Part 2

Calculate the missing values.		
Speed	Distance	Time
130 knots	100 nautical miles	<b>46 minutes</b>
85 knots	<b>213 nautical miles</b>	2.5 hours
<b>59 knots</b>	250 nautical miles	4 hours 15 minutes
<b>300 knots</b>	25 nautical miles	5 minutes
65 knots	200 statute miles	<b>2 hours 41 minutes</b>
78 miles per hour	55 nautical miles	<b>48 minutes</b>
330 km/h	300 km	<b>55 minutes</b>
95 km/h	45 nautical miles	<b>52 minutes</b>
<b>188 km/h</b>	1000 km	320 minutes
<b>1650 knots</b>	55 nautical miles	2 minutes
122 miles per hour	<b>159 statute miles</b>	1.3 hours
101 knots	<b>76 nautical miles</b>	45 minutes
150 knots	5525 m	<b>1 minute</b>

THIS PAGE INTENTIONALLY LEFT BLANK



**ROYAL CANADIAN AIR CADETS  
PROFICIENCY LEVEL FOUR  
INSTRUCTIONAL GUIDE**



**SECTION 4**

**EO C437.02 – USE A VISUAL FLIGHT RULES (VFR) NAVIGATION CHART (VNC)**

---

Total Time:	60 min
-------------	--------

---

**PREPARATION**

---

**PRE-LESSON INSTRUCTIONS**

Resources needed for the delivery of this lesson are listed in the lesson specification located in A-CR-CCP-804/PG-001, *Proficiency Level Four Qualification Standard and Plan*, Chapter 4. Specific uses for said resources are identified throughout the instructional guide within the TP for which they are required.

Review the lesson content and become familiar with the material prior to delivering the lesson.

Select coordinates of landmarks on a local VNC.

**PRE-LESSON ASSIGNMENT**

Nil.

**APPROACH**

An interactive lecture was chosen for TPs 1 and 2 to clarify, emphasize, and summarize types of projections and aeronautical charts.

A demonstration and performance was chosen for TPs 3–6 as it allows the instructor to explain and demonstrate using a VNC while providing an opportunity for the cadets to practice using a VNC under supervision.

---

**INTRODUCTION**

---

**REVIEW**

Nil.

**OBJECTIVES**

By the end of this lesson the cadet shall have used a VNC.

**IMPORTANCE**

It is important for cadets to use a VNC as it is a skill required for flight planning and en route navigation. The VNC is the principal chart used in flight at low altitudes and slow speeds. Many of the skills used with this chart are transferable to other types of maps both in the air and on the ground. Knowledge of this material is essential for future aviation training and potential instructional duties at the squadron.

**Teaching Point 1****Explain types of projections.**

Time: 5 min

Method: Interactive Lecture

Earth is a sphere, so its surface cannot be represented accurately on a flat plane. Therefore, a map shows a portion of the Earth's surface with some distortion. There are four basic elements in map construction:

- areas,
- shapes,
- bearings, and
- distances.

Depending on the particular purpose of the map, one or more of these elements is preserved with minimal distortion, with the most distortion in the remaining elements.



Using the globe and the sheet of construction paper, demonstrate the impossibility of wrapping the sheet around the globe smoothly to create a chart.

The two principal types of chart projections used in air navigation charts are:

- the Lambert Conformal Conic Projection, and
- the Transverse Mercator Projection.

**THE LAMBERT CONFORMAL CONIC PROJECTION**

Using the globe and the sheet of construction paper, demonstrate superimposing a cone over the surface of the globe.

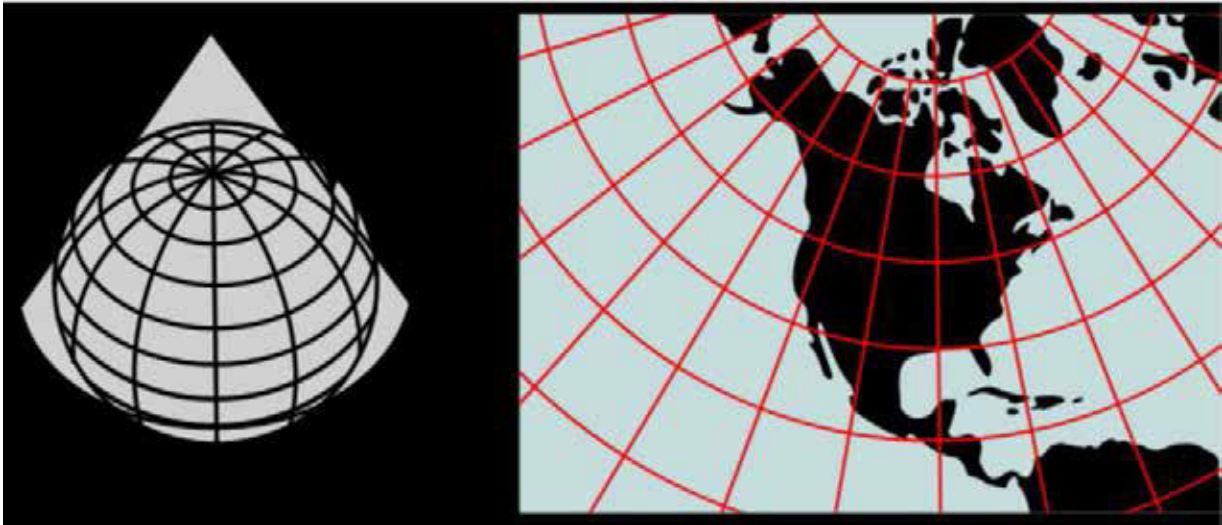

Figure 1 Lambert Conformal Conic Projection

*Note.* From "Image: Lambert Conformal Conic", *Wikimedia*. Retrieved November 27, 2008, from [http://commons.wikimedia.org/wiki/Image:Lambert\\_conformal\\_conic.svg](http://commons.wikimedia.org/wiki/Image:Lambert_conformal_conic.svg)

The properties of the Lambert Conformal Conic Projection are:

- Meridians of longitude are slight curves or straight lines converging toward the nearer pole.
- Parallels of latitude are curves which are concave toward the nearer pole.
- The scale of distance is uniform throughout the entire chart.
- A straight line drawn between any two points on the chart represents an arc of a great circle.

VNCs and World Aeronautical Charts (WACs) are examples of Lambert Conformal Conic Projections.

**The Transverse Mercator Projection.** Applies the Mercator technique by rotating the cylinder 90 degrees so the point of tangency is a meridian of longitude rather than the equator. This projection is accurate in depicting scale, especially on charts covering a relatively small geographical area. The VFR Terminal Area (VTA) Charts are examples of Transverse Mercator Projections.



Using the globe and the sheet of flip chart paper, demonstrate wrapping a cylinder around the globe with its point of tangency at a meridian of longitude.

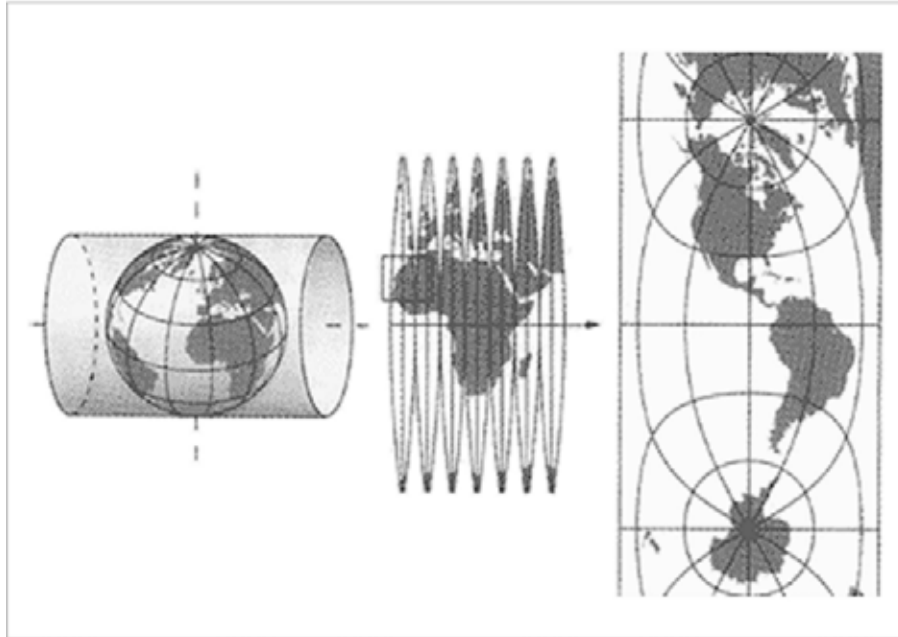

Figure 2 Transverse Mercator Projection

*Note.* From "Swiss Map Projections", 2008, *Federal Office of Topography Swisstopo*. Retrieved November 27, 2008, from <http://www.swisstopo.admin.ch/internet/swisstopo/en/home/topics/survey/sys/refsys/projections.html>

---

## CONFIRMATION OF TEACHING POINT 1

### QUESTIONS:

- Q1. What does a straight line drawn between any two points on a Lambert Conformal Conic Projection represent?
- Q2. What are two examples of Lambert Conformal Conic Projections?
- Q3. What is an example of a Transverse Mercator Projection?

### ANTICIPATED ANSWERS:

- A1. An arc of a great circle.
- A2. VNCs and WACs.
- A3. A VTA Chart is an example of a Transverse Mercator Projection.



**Teaching Point 2****Describe types of aeronautical charts.**

Time: 5 min

Method: Interactive Lecture

**VFR NAVIGATION CHART (VNC)**

Show the cadets a VNC.

VNCs are designed primarily for visual navigation at low altitudes and slow speeds. Each chart is identified by the name of a principal landmark on the chart (eg, Toronto, Winnipeg, Gander). The scale of the chart is 1 : 500 000 or about one inch to eight miles.

**WORLD AERONAUTICAL CHART (WAC)**

Show the cadets a WAC.

WACs are designed primarily for visual navigation at higher altitudes and greater speeds. Each chart depicts a sizeable portion of the country's geographical area—eighteen charts cover Canada. Each chart is identified by a letter and a number. For example, E17 covers the area from Marathon, Ont., west to Brandon, Man., and from the 48<sup>th</sup> parallel north to Thompson, Man. The scale of the chart is 1 : 1 000 000 or about one inch to 16 miles.

**VFR TERMINAL AREA (VTA) CHART**

Show the cadets a VTA Chart.

VTA Charts are large scale charts (1 : 250 000) published for airports where there is a high volume of air traffic and where there is usually a mix of controlled airspace. Radio communication information and other information that is necessary for conducting flight through the area are given on the chart.

**ENROUTE CHART**

Show the cadets an Enroute Chart.

Enroute Charts provide information for radio navigation over designated airways systems. Enroute Charts do not portray any cities, towns, or topographical features. They depict all radio navigation aids, including airways, beacons, reporting points, and communication frequencies. Examples of Enroute Charts are Enroute Low Altitude Charts, Enroute High Altitude Charts, and Terminal Area Charts.



**Canada Flight Supplement (CFS).** A joint civil / military flight information publication and a supplement of the Aeronautical Information Publication (AIP). It contains information on Canadian and North Atlantic aerodromes. The CFS is designed to be used in conjunction with all Canadian charts and should be carried by every pilot departing on a flight. It is revised and reissued every 56 days.

## CONFIRMATION OF TEACHING POINT 2

### QUESTIONS:

- Q1. What is the scale of a VNC?  
 Q2. What are WACs primarily used for?  
 Q3. What are Enroute Charts used for?

### ANTICIPATED ANSWERS:

- A1. 1 : 500 000.  
 A2. Visual navigation at higher altitudes and greater speeds.  
 A3. Radio navigation.

## Teaching Point 3

**Explain, demonstrate and have the cadets practice locating landmarks on a VNC using latitude and longitude.**

Time: 15 min

Method: Demonstration and Performance



For this TP, it is recommended that the instructor take the following format:

1. Explain and demonstrate the skill while the cadets observe.
2. Explain and demonstrate each step required to complete the skill. Monitor cadets as they imitate each step.
3. Monitor the cadets' performance as they practice the skill.

Note: Assistant instructors may be used to monitor the cadets' performance.

## USE LATITUDE AND LONGITUDE TO LOCATE LANDMARKS ON A VNC



The cadets were introduced to latitude and longitude in EO M437.01 (Define Air Navigation Terms). They were asked to find the coordinates of a major airport. In this TP, the cadets are given the coordinates and asked to find the landmarks. They should require minimal instruction as it is a review.



Give the cadets coordinates of several landmarks on a local VNC and have them identify the landmarks.

For example, 43°59'N, 80°17'W is a soaring site (Grand Valley).



Figure 3 Example of a VNC

*Note.* From *Toronto VFR Navigation Chart*, by Geomatics Canada, 2001, Ottawa, ON: Geomatics Canada Department of Natural Resources. Copyright 2001 by NAV CANADA and Her Majesty the Queen in Right of Canada.

### CONFIRMATION OF TEACHING POINT 3

The cadets' participation in locating landmarks on a VNC using latitude and longitude will serve as the confirmation of this TP.

#### Teaching Point 4

**Explain, demonstrate and have the cadets practice plotting tracks between landmarks on a VNC.**

Time: 5 min

Method: Demonstration and Performance



For this TP, it is recommended that the instruction take the following format:

1. Explain and demonstrate the skill while the cadets observe.
2. Explain and demonstrate each step required to complete the skill. Monitor cadets as they imitate each step.
3. Monitor the cadets' performance as they practice the skill.

Note: Assistant instructors may be used to monitor the cadets' performance.

## PLOT A TRACK BETWEEN LANDMARKS ON A VNC

To plot a track between landmarks on a VNC:

1. Identify the landmarks.
2. Use a ruler to draw a straight line between the landmarks.



Give the cadets coordinates of a departure aerodrome and a destination aerodrome on a local VNC. Have them plot a track.



More advanced flight plan plotting (eg, 10-degree drift lines) will be taught during future aviation training.

---

## CONFIRMATION OF TEACHING POINT 4

The cadets' participation in plotting tracks between landmarks on a VNC will serve as the confirmation of this TP.

---

### Teaching Point 5

**Explain, demonstrate and have the cadets practice measuring distances on a VNC.**

Time: 10 min

Method: Demonstration and Performance



For this TP, it is recommended that the instruction take the following format:

1. Explain and demonstrate the skill while the cadets observe.
2. Explain and demonstrate each step required to complete the skill. Monitor cadets as they imitate each step.
3. Monitor the cadets' performance as they practice the skill.

Note: Assistant instructors may be used to monitor the cadets' performance.

## MEASURE DISTANCE ON A VNC

Measure distance on a VNC by:

- using a scale, or
- using an International Civil Aviation Organization (ICAO) ruler.

### Using a Scale

The scale of the chart is the relationship between a unit of distance (eg, one inch) on the chart to the distance that the unit represents on the surface of the Earth.

There are two scales found on a VNC:

- **Representative fraction.** A ratio representing the distance on a map in relation to the surface of the Earth. The representative fraction of a VNC is 1 : 500 000 (one inch on the map represents 500 000 inches or eight miles).
- **Graduated scale line.** Three scale lines printed on the border of the chart representing kilometres, statute miles, and nautical miles. The distance between two locations on a VNC can be compared to one of these lines to give the represented distance in any of the three units of distance.

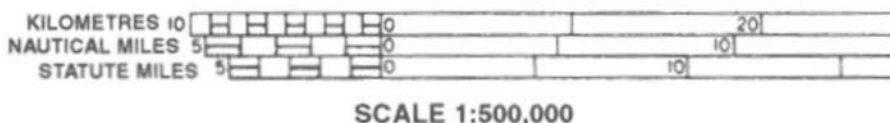

Figure 4 Graduated Scale Line

*Note.* From *From the Ground Up: Millennium Edition* (p. 123), by A. F. MacDonald and I. L. Peppler, 2000, Ottawa, ON: Aviation Publishers Co. Limited. Copyright 2000 by Aviation Publishers Co. Limited.

To measure distance on a VNC using the representative fraction:

1. Use a ruler to measure the distance between two landmarks in inches.
2. Multiply the number of inches by eight to determine the distance in statute miles.

To measure distance on a VNC using the graduated scale:

1. Use a straightedge to measure the distance between two landmarks.
2. Line the straightedge up with the graduated scale, starting at the zero mark, to determine the distance in kilometres, nautical miles, or statute miles.



Have the cadets practice measuring distance using each technique.

### Using an ICAO Ruler

**ICAO ruler.** A plastic straightedge graduated in both statute and nautical miles for use with 1 : 1 000 000 and 1 : 500 000 scale charts. On its reverse side, the ICAO ruler provides conversion factors, VHF reception distances, standard time conversions to Co-ordinated Universal Time (UTC), time equivalencies, flight plan sequences, and an aviation gasoline conversion table.

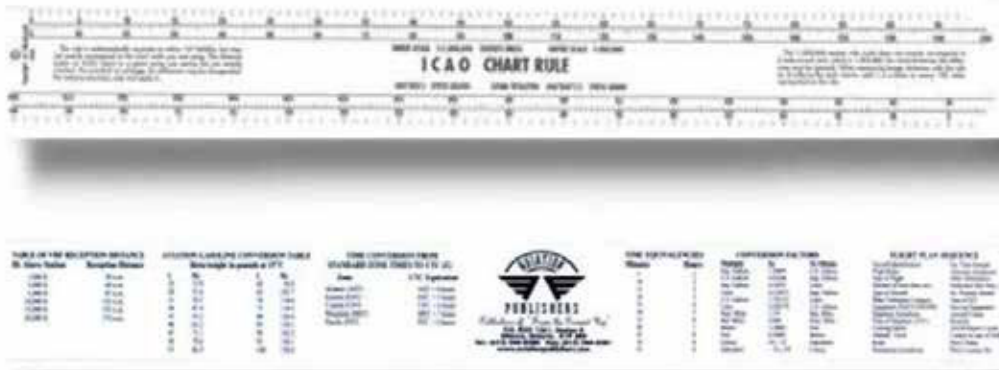



Figure 5 ICAO Ruler

Note. From "Other Publications", *Aviation Publishers*. Retrieved November 28, 2008, from <http://www.aviationpublishers.com/otherpub/icao.html>

To measure distance on a VNC using an ICAO ruler:

1. Align the edge of the ruler with the track. Ensure the zero mark is at one of the landmarks.
2. Read the desired scale (nautical miles or statute miles) where the ruler meets the other landmark.



Use the edge of the ICAO ruler meant for 1 : 500 000 scale charts.



Have the cadets practice measuring distance using this technique.

---

**CONFIRMATION OF TEACHING POINT 5**

The cadets' participation in measuring distances on a VNC will serve as the confirmation of this TP.



**Teaching Point 6****Explain, demonstrate and have the cadets practice determining headings on a VNC.**

Time: 10 min

Method: Demonstration and Performance



For this TP, it is recommended that the instructor take the following format:

1. Explain and demonstrate the skill while the cadets observe.
2. Explain and demonstrate each step required to complete the skill. Monitor cadets as they imitate each step.
3. Monitor the cadets' performance as they practice the skill.

Note: Assistant instructors may be used to monitor the cadets' performance.

**DETERMINE A HEADING ON A VNC**

**Douglas protractor.** A tool used for determining headings and as a straightedge. It is transparent and has a compass rose graduated in 360 degrees marked around the outer edges.

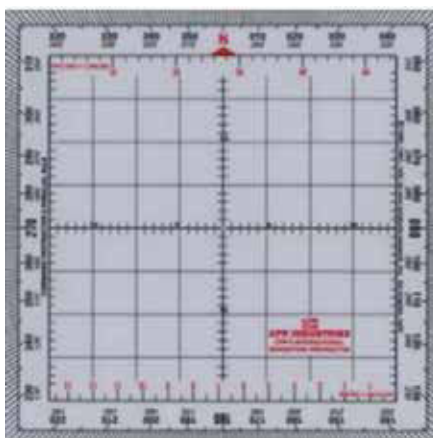

Figure 6 Douglas Protractor

*Note.* From "Douglas Protractor / Parallel Ruler", *VIP Pilot Centre*. Retrieved November 28, 2008, from <http://www.canada-shops.com/Magasin/vippilotcenter/c46907p95758.2.html>

To determine a heading on a VNC using a Douglas protractor:

1. Place the protractor on the chart with the hole in the centre lying on the track at a point where the north-south line on the protractor lies along the meridian of longitude. If this is not convenient, one of the vertical lines can be lined up parallel with the nearest meridian.
2. Read the heading where the track cuts the edge of the protractor.



Have the cadets determine the headings of the tracks previously plotted. Have them plot more tracks and determine the headings as time permits.

---

**CONFIRMATION OF TEACHING POINT 6**

The cadets' participation in determining headings on a VNC will serve as the confirmation of this TP.

---

**END OF LESSON CONFIRMATION**

The cadets' performance of locating landmarks, plotting tracks, measuring distances, and determining headings on a VNC will serve as the confirmation of this lesson.

---

**CONCLUSION**

---

**HOMEWORK / READING / PRACTICE**

Nil.

**METHOD OF EVALUATION**

Nil.

**CLOSING STATEMENT**

Flight planning and navigating at low altitudes and slow speeds relies on being able to use a VNC. Many of the skills used with this chart are transferable to other types of maps both in the air and on the ground.

**INSTRUCTOR NOTES / REMARKS**

Assistant instructors may be required for this lesson.

Cadets who are qualified Advanced Aviation may assist with this instruction.

---

**REFERENCES**

---

C3-116 ISBN 0-9680390-5-7 MacDonald, A. F., & Pepler, I. L. (2000). *From the ground up: Millennium edition*. Ottawa, ON: Aviation Publishers Co. Limited.





**ROYAL CANADIAN AIR CADETS  
PROFICIENCY LEVEL FOUR  
INSTRUCTIONAL GUIDE**



**SECTION 1**

**EO M440.01 – IDENTIFY AEROSPACE MATERIALS**

---

Total Time: 30 min

---

**PREPARATION**

---

**PRE-LESSON INSTRUCTIONS**

Resources needed for the delivery of this lesson are listed in the lesson specification located in A-CR-CCP-804/PG-001, *Proficiency Level Four Qualification Standard and Plan*, Chapter 4. Specific uses for said resources are identified throughout the instructional guide within the TP for which they are required.

Review the lesson content and become familiar with the material prior to delivering the lesson.

Create slides of the figures located at Attachments A and B.

**PRE-LESSON ASSIGNMENT**

Nil.

**APPROACH**

An interactive lecture was chosen for this lesson to introduce aerospace materials and to generate interest in the subject.

---

**INTRODUCTION**

---

**REVIEW**

Nil.

**OBJECTIVES**

By the end of this lesson the cadet shall be expected to identify materials used in aerospace construction.

**IMPORTANCE**

It is important for cadets to learn about materials used in aerospace construction, as it will enhance their understanding of the materials used to build spacecraft and why they are chosen.

---

**Teaching Point 1****Discuss metals used in aerospace construction.**

Time: 15 min

Method: Interactive Lecture

---

**METALS USED IN AEROSPACE CONSTRUCTION**

During this TP, pass around samples of small pieces of components made from aluminum, magnesium, titanium, and stainless steel.

**Aluminum**

Pure aluminum lacks sufficient strength to be used for aerospace construction. However, its strength increases considerably when it is alloyed, mixed with other compatible metals. For example, when aluminum is mixed with copper or zinc, the resultant aluminum alloy is as strong as steel, with only one-third the weight. As well, the considerable corrosion resistance possessed by the aluminum carries over to the newly formed alloy. Aluminum is the most commonly used metal for spacecraft structure.

**Magnesium**

Magnesium is one of the lightest metals with sufficient strength and suitable working characteristics for use in aerospace structures. That is, in its pure form it lacks sufficient strength but, like aluminum, mixing it with other metals to create an alloy produces strength characteristics that make magnesium useful.

**Titanium**

Titanium and its alloys are lightweight metals with very high strength. Pure titanium weighs only half as much as stainless steel and is soft and ductile. Titanium alloys have excellent corrosion resistance, particularly to salt water.

**Stainless Steel**

Stainless steel is a classification of corrosion-resistant steel that contains large amounts of chromium and nickel. It is well suited to high-temperature applications such as firewalls and exhaust system components.

**MATERIAL TESTS**

The study of materials used in aerospace construction is vast and growing rapidly as scientists and engineers gain experience using materials, both new and old, in frontier applications and environments. All materials represent opportunity, but they must be correctly used. Space includes a variety of environments, each with different challenges, such as the Low Earth Orbit (LEO) environment encountered by the International Space Station (ISS) and space shuttle missions. Materials are selected for use in applications after careful study in laboratories, including laboratories in orbit such as the Long Duration Exposure Facility (LDEF).

LDEF was deployed in orbit on April 7, 1984 by the Shuttle Challenger. The nearly circular orbit was at an altitude of 275 nautical miles. LDEF remained in space for about 5.7 years and completed 32,422 Earth orbits. It experienced one-half of a solar cycle, as it was deployed during a solar minimum and retrieved at a solar maximum. LDEF was retrieved on January 11, 1990 by the Shuttle Columbia. By the time LDEF was retrieved, its orbit had decayed to 175 nautical miles and was a little more than one month away from re-entering the atmosphere.



The Long Duration Exposure Facility (LDEF) Archive System, maintained by NASA Langley Research Center, is designed to provide spacecraft designers and space environment researchers with a single point access to all available resources from LDEF. It is found at <http://setas-www.larc.nasa.gov/LDEF/index.html>

## ORBIT ENVIRONMENT

The characteristics of a spacecraft's orbit are determined by its mission. Some spacecraft travel between worlds and must be capable of functioning in a variety of conditions. Most spacecraft, however, are used in an application that restricts them to a narrow range of space environments. The relative impact of any of the space environments' effects on materials depends on the type of mission the spacecraft has to perform (eg, communications, defense, Earth observing) and, more important, the orbits in which the spacecraft is placed.



Show the cadets the slide of Figure A-1 located at Attachment A.

Figure A-1 shows the variations in the space environment as a function of orbit altitude. LEO extends up to 1000 km. Mid-Earth Orbit (MEO) is above 1000 km and extends up to 35 000 km. Geosynchronous orbit (GEO) is 35 000 km and higher.



Show the cadets the slide of Figures A-2 and A-3 located at Attachment A.

Major space environment hazards in LEO include atomic oxygen, ultraviolet radiation, frequent cycling between hot and cold temperatures, micrometeoroids, debris and contamination.



Atomic oxygen (AO) is an elemental form of oxygen that does not exist in the Earth's atmosphere. In space, however, it is common in the LEO area where satellites orbit the Earth. There, it reacts with other materials very easily and exposes satellites and spacecraft to damaging corrosion. Researchers at NASA's Glenn Research Center study these damaging effects in order to find materials and methods to extend the lifetime of communication satellites, the Space Shuttles and the ISS.



Show the cadets the slide of Figure A-4 located at Attachment A.

To prevent AO from damaging metal surfaces, protective coatings are applied to the metal's surface. AO flux and ultraviolet radiation interact in the degradation of silver and Teflon materials.



Cadets can explore Space Weather: Impact of the Orbital Environment on the MOST microsatellite mission at <http://www.astro.ubc.ca/MOST/posters/WS-Kristy-poster.jpg>

Orbital debris is another hazard for materials in LEO. This refers to man-made particles orbiting the Earth. Within about 2 000 km above Earth's surface there is an estimated 3 000 000 kg of man-made orbiting objects. These objects are in mostly high inclination orbits and sweep past one another at an average speed of 10 km / second. These particles are a result of standard launch and spacecraft operations as well as rocket and satellite breakups. Launch and spacecraft operations place both large particles (eg, greater than 1-cm diameter such as satellite shrouds, lens covers, and dropped tools) and small particles (eg, approximately 10-micron diameter solid rocket exhaust) in orbit.

Impacts can alter material states and expose underlying materials, allowing the space environments (eg, AO) to further increase the damage area and begin damaging previously unexposed areas. AO undercutting of polymer substrates under protective coatings is a phenomenon that can be a concern for space applications of multi-layer insulation.

---

## CONFIRMATION OF TEACHING POINT 1

### QUESTIONS:

- Q1. Why is pure aluminum unsuitable for use in many applications of aerospace construction?
- Q2. What three characteristics make titanium useful for aerospace components?
- Q3. What two metals are mixed with steel to make stainless steel?

### ANTICIPATED ANSWERS:

- A1. Pure aluminum lacks sufficient strength for aerospace construction.
- A2. Titanium alloys have high strength, are lightweight and are resistant to corrosion.
- A3. Steel is mixed with chromium and nickel.

---

## Teaching Point 2

**Discuss composite materials used in aerospace construction.**

Time: 10 min

Method: Interactive Lecture

---

## COMPOSITE CONSTRUCTION



The term composite refers to a combination of two or more materials that differ in composition or form. Composite is sometimes used to mean any synthetic building material.

Composite structures differ from metallic structures in important ways: excellent elastic properties, high strength combined with light weight and the ability to be customized in strength and stiffness. The fundamental nature of many composites comes from the characteristics of a strong fibre cloth imbedded in a resin.



Pass around clearly marked samples of fibreglass cloth, aramid cloth and carbon fibre cloth.

### Fibreglass

Fibreglass is made from strands of silica glass that are spun together and woven into cloth. Fibreglass weighs more and has less strength than most other composite fibres. However, improved matrix materials now allow fibreglass to be used in advanced composite aerospace applications.

There are different types of glass used in fibreglass: E-glass, which has a high resistance to electric current and S-glass, which has a higher tensile strength, meaning that the fabric made from it resists tearing.

### Aramid

Aramid is a polymer. A polymer is composed of one or more large molecules that are formed from repeated units of smaller molecules.



Ask the cadets to name all the applications they are aware of for Kevlar®.

The best-known aramid material is Kevlar®, which has a tensile strength approximately four times greater than the best aluminum alloy. This cloth material is used in many applications where great strength is needed: canoes, body armour and helicopter rotors. Aramid is ideal for aerospace parts that are subject to high stress and vibration. The aramid's flexibility allows it to twist and bend in flight, absorbing much of the stress. In contrast, a metal part would develop fatigue and stress cracks sooner under the same conditions.

### Carbon / Graphite

The term carbon is often used interchangeably with the term graphite; however, they are not quite the same material. Carbon fibres are formed at 1315 degrees Celsius (2400 degrees Fahrenheit), but graphite fibres are produced only above 1900 degrees Celsius (3450 degrees Fahrenheit). As well, their actual carbon content differs—but both carbon and graphite materials have high compressive strength and stiffness.

Carbon molecules will form long strings that are extremely tough (this is what makes diamonds so strong). These minute hair-like strands of carbon (a very common and inexpensive element) are, per unit of weight, many times stronger than steel. Individual carbon fibres are flexible, rather than stiff, and bend easily despite having high tensile strength. To stiffen the fibres, cross-directional layers are immersed in a matrix material such as epoxy plastic. A matrix is any material that sticks them together.



The term epoxy refers to a substance derived from an epoxide. An epoxide is a carbon compound containing an oxygen atom bonded in a triangular arrangement to two carbon atoms. So, an epoxy matrix is itself carbon-based, as are the fibres that it binds.

### Ceramic

Ceramic fibre is a form of glass fibre designed for use in high temperature applications. It can withstand temperatures approaching 1650 degrees Celsius (3000 degrees Fahrenheit), making it effective for use around engines and exhaust systems.



Show the cadets the slide of Figure B-1 located at Attachment B.

Ceramic's disadvantages include both weight and expense, but sometimes no other known material will do the job. One of the most famous applications of ceramic is the Thermal Protection System (TPS) used on the space shuttle. The properties of aluminum demand that the maximum temperature of the shuttle's structure be kept below 175 degrees Celsius (350 degrees Fahrenheit) during operations. Heating during re-entry (in other words, heating caused by friction with the air) creates surface temperatures high above this level, and in many places will push the temperature well above the melting point of aluminum (660 degrees Celsius or 1220 degrees Fahrenheit).



Underneath its protective layer of tiles and other materials, the space shuttle has an ordinary aluminum construction, similar to many large aircraft.



Show the cadets the slide of Figure B-2 located at Attachment B.

A space shuttle's TPS is very complex and it contains highly sophisticated materials. Thousands of tiles of various sizes and shapes cover a large percentage of the space shuttle's exterior surface. There are two main types of silica ceramic tiles used on the space shuttle:

- **Low-Temperature Reusable Surface Insulation (LRSI).** LRSI tiles cover relatively low-temperature areas of one of the shuttles, the Columbia, where the maximum surface temperature runs between 370 and 650 degrees Celsius (700 and 1200 degrees Fahrenheit), primarily on the upper surface of fuselage around the cockpit. These tiles have a white ceramic coating that reflects solar radiation while in space, keeping the Columbia cool.



Show the cadets the slide of Figure B-3 located at Attachment B.

- **High-Temperature Reusable Surface Insulation (HRSI).** HRSI tiles cover areas where the maximum surface temperature runs between 650 and 1260 degrees Celsius (1200 and 2300 degrees Fahrenheit). They have a black ceramic coating, which helps them radiate heat during re-entry.

Both LRSI and HRSI tiles are manufactured from the same material and their primary difference is the coating.

A different and even more sophisticated material, Reinforced Carbon-Carbon (RCC), is used for the nose cone and leading edges of the space shuttle. It is a composite material consisting of carbon fibre reinforcement in a matrix of graphite, often with a silicon carbide coating to prevent oxidation.

---

**CONFIRMATION OF TEACHING POINT 2****QUESTIONS:**

- Q1. What type of glass is used in fibreglass strands?
- Q2. What is the best known aramid material?
- Q3. What method is used to stiffen carbon fibre materials?

**ANTICIPATED ANSWERS:**

- A1. Silica glass.
- A2. Kevlar®.
- A3. Immersing cross-directional layers of carbon fibres in a matrix compound such as epoxy plastic.

---

**END OF LESSON CONFIRMATION****QUESTIONS:**

- Q1. What are the altitudes of LEO, MEO and GEO orbits?
- Q2. What is the major gas found in LEO?
- Q3. What is the most commonly used metal for spacecraft structure?

**ANTICIPATED ANSWERS:**

- A1. LEO extends up to 1 000 km, MEO is above 1 000 km and extends up to 35 000 km, and GEO is 35 000 km and higher.
- A2. The major gas in LEO is AO.
- A3. Aluminum is the most commonly used metal for spacecraft structure.

---

**CONCLUSION**

---

**HOMEWORK / READING / PRACTICE**

Nil.

**METHOD OF EVALUATION**

Nil.

**CLOSING STATEMENT**

The study of materials used in aerospace construction is a rapidly growing field that holds immense opportunity for development. Space travel demands accurate and creative materials applications.

**INSTRUCTOR NOTES / REMARKS**

Cadets who are qualified Advanced Aerospace may assist with this instruction.

---

**REFERENCES**

---

C3-136 ISBN 0-88487-207-6 Sanderson Training Systems (2001). *A&P technician airframe textbook*. Englewood, CO: Jeppesen Sanderson Inc.

C3-294 Silverman, E. M. (1995). *Space environmental effects on spacecraft: LEO materials selection guide*. Hampton, VA: NASA Langley Research Center. Retrieved November 27, 2008, from <http://see.msfc.nasa.gov/mp/NASA-95-cr4661pt1.pdf>



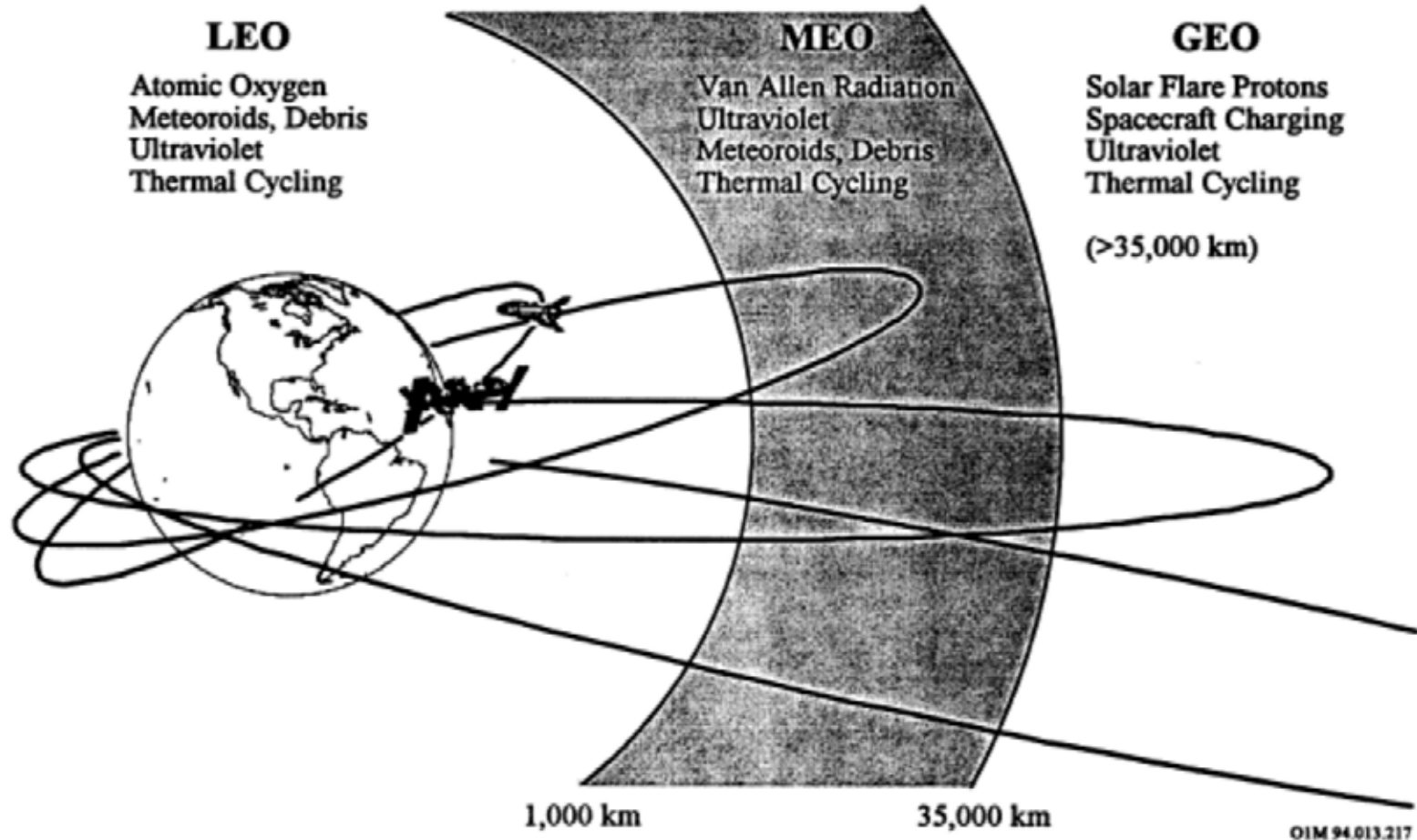

Figure A-1 Variation of Space Environments With Altitude

Note. From *Space Environmental Effects on Spacecraft: LEO Materials Selection Guide*, by E. M. Silverman, 1995, Hampton, VA: NASA Langley Research Center. Retrieved November 27, 2008, from <http://see.msfc.nasa.gov/mp/NASA-95-cr4661pt1.pdf>

<b>Impact</b>	<b>Significance</b>
10	Effects produced will negate the mission
9	Effects produced may negate the mission
8	Effects produced will shorten the mission
7	Effects produced may shorten the mission
6	Effects produced will reduce mission effectiveness
5	Effects produced may reduce mission effectiveness
4	Effects produced will require design changes
3	Effects produced may require design changes
2	Effects produced will cause upsets
1	Effects produced may cause upsets
0	Effects produced can be ignored

Figure A-2 Relative Ranking of the Space Environment Impact on Mission

*Note.* From *Space Environmental Effects on Spacecraft: LEO Materials Selection Guide*, by E. M. Silverman, 1995, Hampton, VA: NASA Langley Research Center. Retrieved November 27, 2008, from <http://see.msfc.nasa.gov/mp/NASA-95-cr4661pt1.pdf>

Spacecraft Environment	LEO <sup>(1)</sup> Low Incl.	LEO High Incl.	MEO <sup>(2)</sup>	GEO <sup>(3)</sup>	Int'l Space Station 500 km 51.6° incl	GPS 20,000km 55° incl
Direct Sunlight	4 <sup>(4)</sup>	4	4	4	4	4
Gravity Field	3	3	3	0	3	0
Magnetic Field	3	3	3	0	3	0
Van Allen Belts	0-5	2-5	8-5	1	2-5	5
Solar flare Particles	0	4	3	5	4	3
Galactic Cosmic Rays	0	4	3	5	4	3
Debris Objects	7	7	3-0	3	7	0
Micrometeoroids	3	3	3	3	3	3
Ionosphere	3	3	1	0	3	0
Hot Plasma	0	3	0	5	0	3
Neutral Gases	9-7	9-7	3-0	0	9-7	0

Figure A-3 Space Environmental Effects

*Note.* From *Space Environmental Effects on Spacecraft: LEO Materials Selection Guide*, by E. M. Silverman, 1995, Hampton, VA: NASA Langley Research Center. Retrieved November 27, 2008, from <http://see.msfc.nasa.gov/mp/NASA-95-cr4661pt1.pdf>

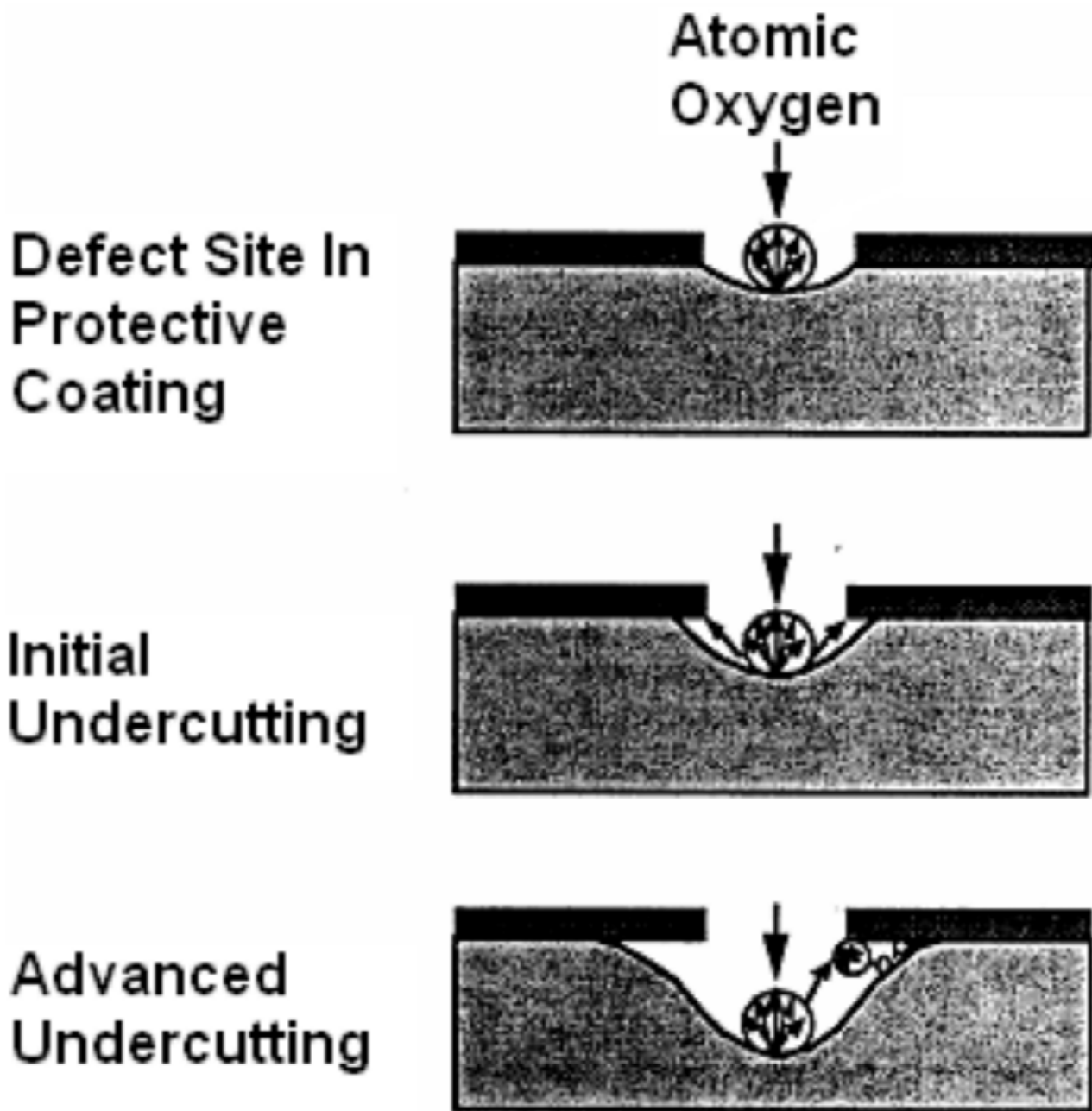

Figure A-4 Atomic Oxygen Undercutting

Note. From *Space Environmental Effects on Spacecraft: LEO Materials Selection Guide*, by E. M. Silverman, 1995, Hampton, VA: NASA Langley Research Center. Retrieved November 27, 2008, from <http://see.msfc.nasa.gov/mp/NASA-95-cr4661pt1.pdf>

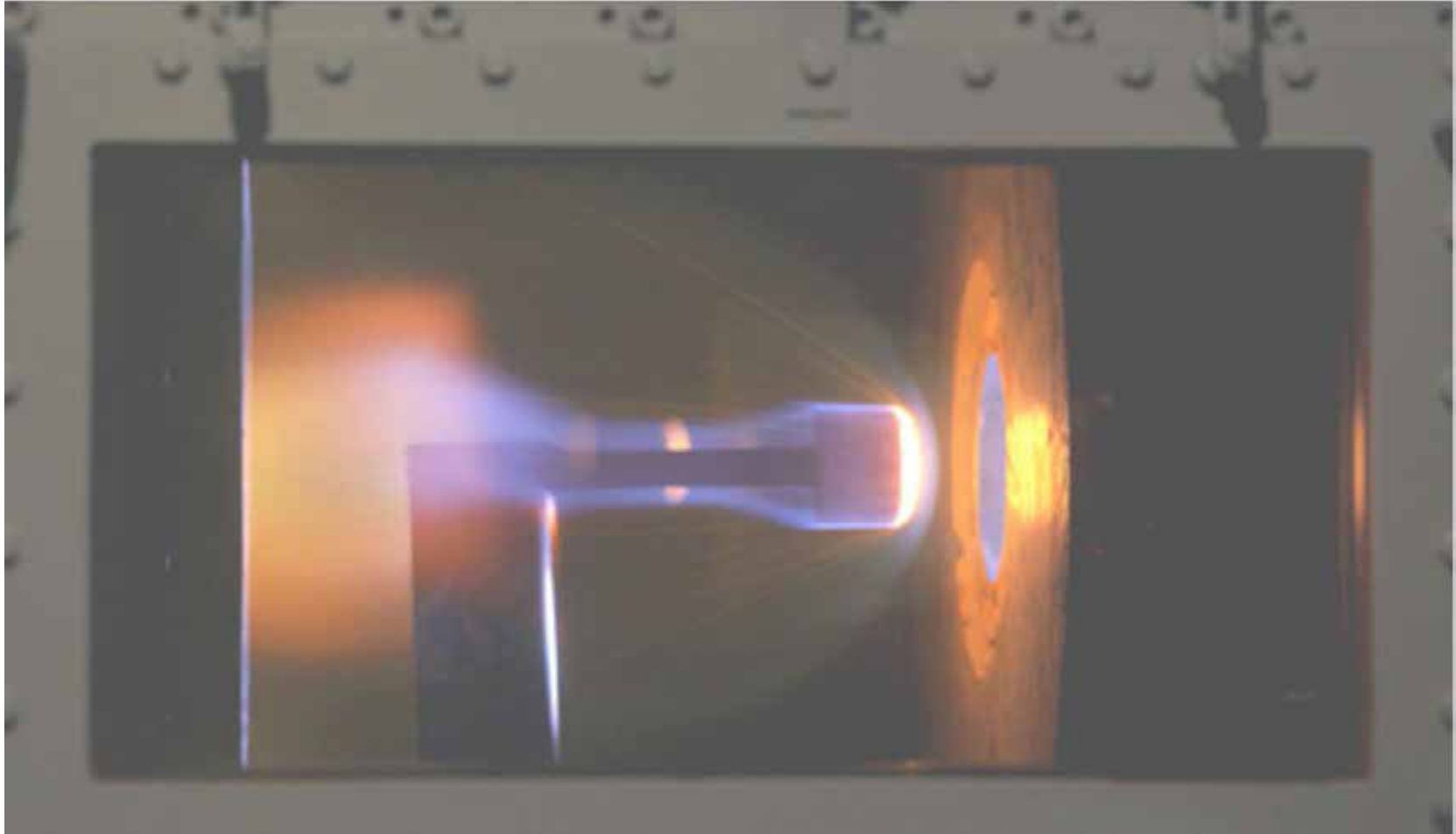

Figure B-1 Testing Thermal Insulation in a Wind Tunnel

*Note.* From "US Centennial of Flight Commission", 2004, *Shuttle Thermal Protection System*. Retrieved November 25, 2007, from [http://www.centennialofflight.gov/essay/Evolution\\_of\\_Technology/TPS/Tech41.htm](http://www.centennialofflight.gov/essay/Evolution_of_Technology/TPS/Tech41.htm)

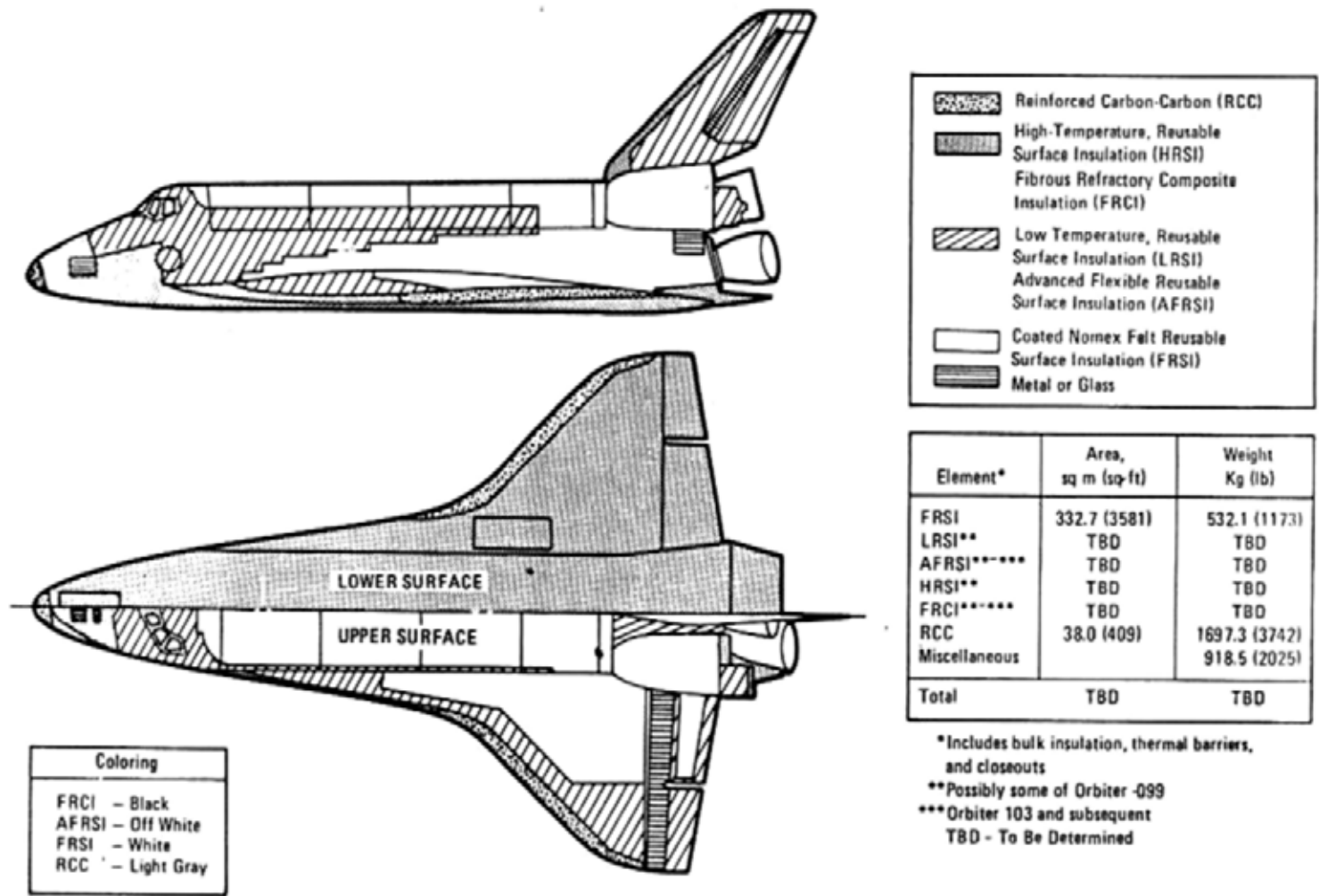

Figure B-2 Orbiter Thermal Protection System

Note. From "US Centennial of Flight Commission", 2004, *Shuttle Thermal Protection System*. Retrieved November 25, 2007, from [http://www.centennialofflight.gov/essay/Evolution\\_of\\_Technology/TPS/Tech41.htm](http://www.centennialofflight.gov/essay/Evolution_of_Technology/TPS/Tech41.htm)



Figure B-3 Repairing TPS on Columbia

*Note.* From "US Centennial of Flight Commission", 2004, *Shuttle Thermal Protection System*. Retrieved November 25, 2007, from [http://www.centennialofflight.gov/essay/Evolution\\_of\\_Technology/TPS/Tech41.htm](http://www.centennialofflight.gov/essay/Evolution_of_Technology/TPS/Tech41.htm)

THIS PAGE INTENTIONALLY LEFT BLANK





**ROYAL CANADIAN AIR CADETS  
PROFICIENCY LEVEL FOUR  
INSTRUCTIONAL GUIDE**



**SECTION 2**

**EO M440.02 – DESCRIBE CANADIAN SATELLITES**

---

Total Time:	30 min
-------------	--------

---

**PREPARATION**

---

**PRE-LESSON INSTRUCTIONS**

Resources needed for the delivery of this lesson are listed in the lesson specification located in A-CR-CCP-804/PG-001, *Proficiency Level Four Qualification Standard and Plan*, Chapter 4. Specific uses for said resources are identified throughout the instructional guide within the TP for which they are required.

Review the lesson content and become familiar with the material prior to delivering the lesson.

Make slides of Attachments A–C.

**PRE-LESSON ASSIGNMENT**

Nil.

**APPROACH**

An interactive lecture was chosen for this lesson to orient the cadets to Canadian satellites and to generate interest in the subject.

---

**INTRODUCTION**

---

**REVIEW**

Nil.

**OBJECTIVES**

By the end of this lesson the cadet shall be expected to describe selected Canadian satellites.

**IMPORTANCE**

It is important for cadets to be familiar with Canadian satellites so they can appreciate the Canadian space program, which is an important element of air cadet training.

**Teaching Point 1****Identify aspects of the Alouette program.**

Time: 5 min

Method: Interactive Lecture

**HISTORY**

Launched on September 29, 1962, the Alouette-I scientific satellite marked Canada's entry into the space age and was seen by many as initiating the most progressive space program of that era.



Show the cadets Figures A-1 and A-2 located at Attachment A.

With the Alouette launch, Canada became the first nation after the Soviet and American superpowers, to design and build its own artificial Earth satellite.

**PURPOSE**

The development of Alouette-I came as a result of an American invitation, through the newly formed National Aeronautics and Space Administration (NASA) in 1958, for international collaboration in its budding satellite program. Within months, scientists at Canada's Defence and Research Telecommunications Establishment (DRTE) submitted a proposal to NASA for a Canadian satellite that could monitor the top of the ionosphere, an upper layer of the earth's atmosphere that is ionized by solar wind.



The solar wind is so hot it becomes fully ionized plasma, which means that the atoms have become separated from their electrons. This streaming plasma flows past Earth, affects the Earth's magnetic field and magnetosphere, and creates the ionosphere by removing electrons from atoms of gas in the atmosphere. The Earth's atmosphere receives a lot of energy from the sun in the form of radiation—about 1 370 watts per square metre. That is enough energy to power six desktop computers, coming from an area that would barely hold one computer.

Ground-based techniques used to study the ionosphere are similar to radar. Radio pulses are transmitted from the ground and reflected back by the ionized layer of atmosphere. The elapsed time is used to calculate the height of the layers. The equipment used to make these measurements is an ionosonde. The Canadian proposal was to integrate an ionosonde into a satellite.

The objectives were twofold, both primary and scientific:

1. Primary objectives were:
  - a. to bring Canada into the space age by developing a space capability;
  - b. to contribute to space engineering and technology; and
  - c. to improve the capability of high frequency (HF) radio communications by studying the ionosphere from above.

2. Scientific objectives were:
- a. to measure the electron density distribution in the ionosphere at altitudes between 300 and 1 000 km;
  - b. to study, for a one-year period, the variations of electron density distribution with regard to time of day and latitude under varying magnetic and auroral conditions, with particular emphasis on high latitude effects; and
  - c. to determine electron densities in the vicinity of the satellite by means of galactic noise measurement and to make observations of related physical phenomena, such as the flux of energetic particles.

### **ACCOMPLISHMENTS**

Alouette-I was a tremendous success. The conservative research approach adopted by the DRTE team paid off as the satellite eventually stretched its one-year design life into an unprecedented 10-year mission, producing more than one million images of the ionosphere.

Following the success of Alouette-I, Canada and the United States signed an agreement to launch further satellites under a new program called International Satellites for Ionospheric Studies (ISIS). Under the ISIS program, the Alouette backup model, Alouette-II, was refurbished and flown in 1965 and two new satellites, named ISIS I and ISIS II, were successfully launched in 1969 and 1970 respectively.

### **CONFIRMATION OF TEACHING POINT 1**

#### **QUESTIONS:**

- Q1. What was the year of Alouette's first launch?
- Q2. What was Alouette designed to do?
- Q3. What program followed the success of Alouette?

#### **ANTICIPATED ANSWERS:**

- A1. 1962.
- A2. To monitor the ionosphere from above.
- A3. The ISIS program.

### **Teaching Point 2**

### **Identify aspects of the Microvariability and Oscillation of Stars (MOST) mission.**

Time: 10 min

Method: Interactive Lecture

### **HISTORY**

MOST is Canada's space telescope in orbit. It is sometimes referred to as the "Hubble Space Telescope" due to its physical size, despite its effectiveness and accomplishments.



Show the cadets Figures B-1 and B-2 located at Attachment B.

The four partners who designed and created MOST are:

- Canadian Space Agency (CSA),
- University of British Columbia (UBC) (Physics and Astronomy),
- University of Toronto Institute for Aerospace Studies (UTIAS), and
- Dynacon Enterprises Limited (main contractor, mission operations).

The MOST science team includes representatives from various organizations, which include:

- University of British Columbia (UBC),
- St. Mary's University,
- L'Université de Montréal,
- University of Toronto David Dunlap Observatory (DDO),
- Harvard-Smithsonian Center, and
- University of Vienna.

MOST was carried aloft aboard a Russian three-stage rocket on June 30, 2003, from a launch site in northern Russia (Plesetsk). MOST was injected into a low-Earth polar orbit at approximately 820 km altitude with an orbital period of approximately 100 minutes in a sun-synchronous mode remaining over the Earth's terminator (the line between day and night).



Sun-synchronous means that, although MOST orbits Earth, it also maintains its orientation to the sun.



Show the cadets Figures B-3 to B-5 located at Attachment B. For orbit information, cadets can visit <http://www.astro.ubc.ca/MOST/galleries.html#movies>

From that vantage point, MOST will have a Continuous Viewing Zone (CVZ) spanning declinations from about -19 to +36 degrees, in which a selected target star will remain observable for up to 60 days without interruption.



UBC has a collection of MOST training eClips and explanations located at their MOST website at <http://www.astro.ubc.ca/MOST/galleries.html#movies>

## PURPOSE

The stated purposes of the MOST space telescope are the detection and characterization of:

- acoustic oscillations in sun-like stars, including very old stars (metal-poor subdwarfs) and magnetic stars (roAp), to probe seismically their structures and ages;
- reflected light from giant exoplanets closely orbiting sun-like stars, to reveal their sizes and atmospheric compositions; and
- turbulent variations in massive evolved (Wolf-Rayet) stars to understand how they add gas to the interstellar medium.

MOST, therefore, is an attempt to answer important question about stars, such as:

- Can we understand our sun in the context of other stars?
- By putting a birthdate on the oldest stars in the solar neighbourhood, can we set a limit on the age of the universe?
- How do strong magnetic fields affect the physics of other stars and our own sun?
- What are mysterious planets around other stars really like?
- How did the atoms that make up our planet and our bodies escape from stars in the first place?

## ACCOMPLISHMENTS

Although the MOST space telescope is often referred to as the Hubble telescope because of its size next to the Hubble Space Telescope (HST), the accomplishments of MOST are anything but humble. MOST turned out to be a precocious child. The team of scientists and engineers—located from coast to coast across Canada and in Harvard and Vienna—has extended the capabilities of this "little telescope that could" to explore exoplanets (alien worlds around other stars). MOST has measured the properties of several of these planets, which are invisible even to the largest telescopes. Among the findings of MOST is a planet whose atmosphere is either so clear or so hazy that it reflects only four percent of the light it receives from its parent sun.



For information about MOST observations, visit the MOST Science website at <http://www.astro.ubc.ca/MOST/science.html>

---

## CONFIRMATION OF TEACHING POINT 2

### QUESTIONS:

- Q1. What year was that the MOST telescope carried aloft?
- Q2. What sort of orbit does MOST have?
- Q3. What viewing opportunity does MOST's orbit provide?

**ANTICIPATED ANSWERS:**

- A1. 2003.
- A2. A low-Earth polar orbit.
- A3. A CVZ spanning declinations from about -19 to +36 degrees, in which a selected target star will remain observable for up to 60 days without interruption.

---

**Teaching Point 3**

**Identify aspects of the RADARSAT program.**

Time: 10 min

Method: Interactive Lecture

---

**HISTORY**

The RADARSAT program was born out of the need for effective monitoring of Canada's waters. Canada is a world leader in the operational use of space radar for sea ice monitoring. Earth-observation satellites have an advantage over aerial surveillance missions. Satellites operate day and night in all weather conditions and provide timely coverage of vast areas.



Show the cadets Figure C-1 located at Attachment C.

RADARSAT is Canada's first series of remote-sensing satellites. RADARSAT-1 was launched in 1995 and RADARSAT-2 in 2007. These satellites focus on the use of radar sensors to provide unique information about the Earth's surface through most weather conditions and darkness. A technique known as synthetic-aperture radar (SAR) is used by RADARSAT satellites to increase the resolution of images by taking advantage of the fact that the satellite's small aperture is constantly moving. The many echo waveforms received at the different antenna positions are then post-processed by a computer in order to resolve the target with high definition. Post-processing by a computer is also the technique used by Global Positioning System (GPS) receivers to eliminate location ambiguities.

**PURPOSE**

**Marine Surveillance**

Worldwide offshore resource-based operations such as fishing, oil and gas exploration and production have intensified over the past few decades. Government and industry require powerful solutions for assessing the resources and risks associated with the ocean environment. To monitor the world's oceans, Canada has provided radar data for operational applications such as ship detection, oil spill monitoring, and wind and surface-wave field estimation.

RADARSAT-2 improves ship detection with its ultra-fine beam mode, which can resolve objects down to 3 m on a side, and offers the potential for ship classification.

**Disaster Management**

Radar satellites are key resources in a variety of disaster management scenarios. The data has been used effectively in disaster responses such as earthquakes, tsunamis, floods, landslides, forest fires, and other natural or technological disasters such as a large oil spill in Japan. On January 2, 1997, the Nakhodka, a Russian oil tanker, broke apart during a storm 130 km (80 miles) off the coast of Japan's Shimane Prefecture.



Show the cadets Figure C-2 located at Attachment C. The inset view in Figure C-2 shows the location of the Wakasa Bay nuclear reactors.

At one point the spill threatened one of the most concentrated areas of nuclear reactors in the world. The oil slicks came close to the 15 reactors in Japan's Wakasa Bay but the cleanup effort was able to keep the oil from seeping into the reactor's intake pipes, which serve to cool the reactors with seawater. Officials stated that in the worst case, if the oil had seeped into the pipes, plant operators would simply have been forced to suspend power. RADARSAT images served to define the extent and shape of the oil spill during this disaster.



The ability to deliver data in near-real time is essential for relief operations to map and monitor damage and for assessing impact.

RADARSAT-2 reduces planning lead times for data acquisition and, because it can look both right and left, provides more revisits and up-to-date data than its predecessor.

There are unlimited uses for RADARSAT image data. An example is the use of RADARSAT images by Research Institute for Advanced Mechanics (RIAM) of the Kyushu University Dynamics Simulation Research Center to develop a computer model of the Nakhodka oil spill.



Show the cadets Figure C-3 located at Attachment C.

RADARSAT images, such as the ones seen in Figure C-3, were used in creating computer programs that simulate the spreading of spilled oil.



Show the cadets Figure C-4 located at Attachment C.

Dated images of the computer program output are shown in Figure C-4. Computer analysis is now available to predict the effects of future oil spills and assist with environmental cleanup.

## Hydrology

Water is one of Earth's most precious and widely used resources. RADARSAT-2 enhances soil moisture measurement, and snow pack monitoring and analysis, while improving the potential for SAR in wetland mapping and discrimination. This will benefit mapping applications involving coastlines, tidal and near-shore terrestrial areas, and near-shore bathymetry (depth measurements).

## Mapping

Mapping covers a broad range of activities, including the creation of Digital Elevation Models (DEMs), the detection and mapping of centimetre-scale movements at the Earth's surface (InSAR), and the extraction and identification of features to support environment management and security.

RADARSAT-2's advanced technology provides improved capabilities for mapping. Highly accurate positional information and control over the RADARSAT-2 orbit ensures absolute quality for end products, such as DEMs and InSAR.

### **Geology**

Satellite radar data is very useful in geological exploration and mapping activities for petroleum and mineral resources. Canadian radar data is used for both onshore and offshore exploration and mapping and to monitor and detect oil seeps, which reduces the risk and cost of drilling. The Southern African Institute of Mining and Metallurgy reports the use of remote sensing by diamond mining companies in South Africa, listing RADARSAT images as among the most useful.

### **Agriculture**

Abundant harvests and crop yields partly depend on soil dynamics that fluctuate throughout the growing season. Satellite imagery is an efficient method for mapping crop characteristics over large spatial areas and tracking temporal changes in soil and crop conditions.

Built into RADARSAT-2 are several powerful features that respond directly to the needs of the agricultural sector. Valuable crop information can be extracted from one RADARSAT-2 image and there is no need for image data acquisition over several dates. RADARSAT provides important information about climate change.

### **Forestry**

With more than 30 percent of the Earth's total land area covered in forests, it is no small feat to assess and monitor forest resources. Satellite imagery is the most efficient method for coverage of forested areas.

Several applications in forestry have benefited from Canadian radar data, in particular clear-cut mapping. High-resolution data from RADARSAT-2 may improve forest-type mapping using textural analysis.

## **ACCOMPLISHMENTS**

The RADARSAT Program continues Canada's tradition of providing world leadership in advancing Earth-observation technologies and techniques. Natural Resources Canada—one of RADARSAT's main customers—observes that RADARSAT's unparalleled operational flexibility and reliable delivery provides high quality and cost-effective data to researchers and environmental professionals world-wide.

---

## **CONFIRMATION OF TEACHING POINT 3**

### **QUESTIONS:**

- Q1. What kind of satellites are RADARSAT satellites?
- Q2. In what year was the first RADARSAT launch?
- Q3. What are three purposes of the RADARSAT program?

### **ANTICIPATED ANSWERS:**

- A1. Earth-observation satellites.
- A2. RADARSAT-1 was launched in 1995.
- A3. Any three chosen from: marine surveillance, disaster management, hydrology, mapping, geology, agriculture and / or forestry.



---

**END OF LESSON CONFIRMATION****QUESTIONS:**

- Q1. What job was Alouette designed to do?
- Q2. What does MOST's orbit provide?
- Q3. What are three purposes of the RADARSAT program?

**ANTICIPATED ANSWERS:**

- A1. To monitor the ionosphere from above.
- A2. A CVZ spanning declinations from about -19 to +36 degrees, in which a selected target star will remain observable for up to 60 days without interruption.
- A3. Any three chosen from: marine surveillance, disaster management, hydrology, mapping, geology, agriculture and / or forestry.

---

**CONCLUSION**

---

**HOMEWORK / READING / PRACTICE**

Nil.

**METHOD OF EVALUATION**

Nil.

**CLOSING STATEMENT**

Canadian space missions affect many aspects of life, from telecommunications to environmental protection and pure science. Intended and unintended applications of Canada's space research continue to benefit other industries.

**INSTRUCTOR NOTES / REMARKS**

Cadets who are qualified Advanced Aerospace may assist with this instruction.

---

**REFERENCES**

---

C3-253 Canadian Space Agency. (2008). *Alouette I and II*. Retrieved September 29, 2008, from <http://www.space.gc.ca/asc/eng/satellites/alouette.asp>

C3-254 University of British Columbia. (2008). *MOST: Canada's first space telescope*. Retrieved September 29, 2008, from <http://www.astro.ubc.ca/MOST/overview.html#glance>

C3-255 Natural Resources Canada. (2008). *Canada centre for remote sensing: RADARSAT*. Retrieved September 29, 2008, from [http://www.ccrs.nrcan.gc.ca/radar/spaceborne/radarsat1/index\\_e.php](http://www.ccrs.nrcan.gc.ca/radar/spaceborne/radarsat1/index_e.php)

THIS PAGE INTENTIONALLY LEFT BLANK

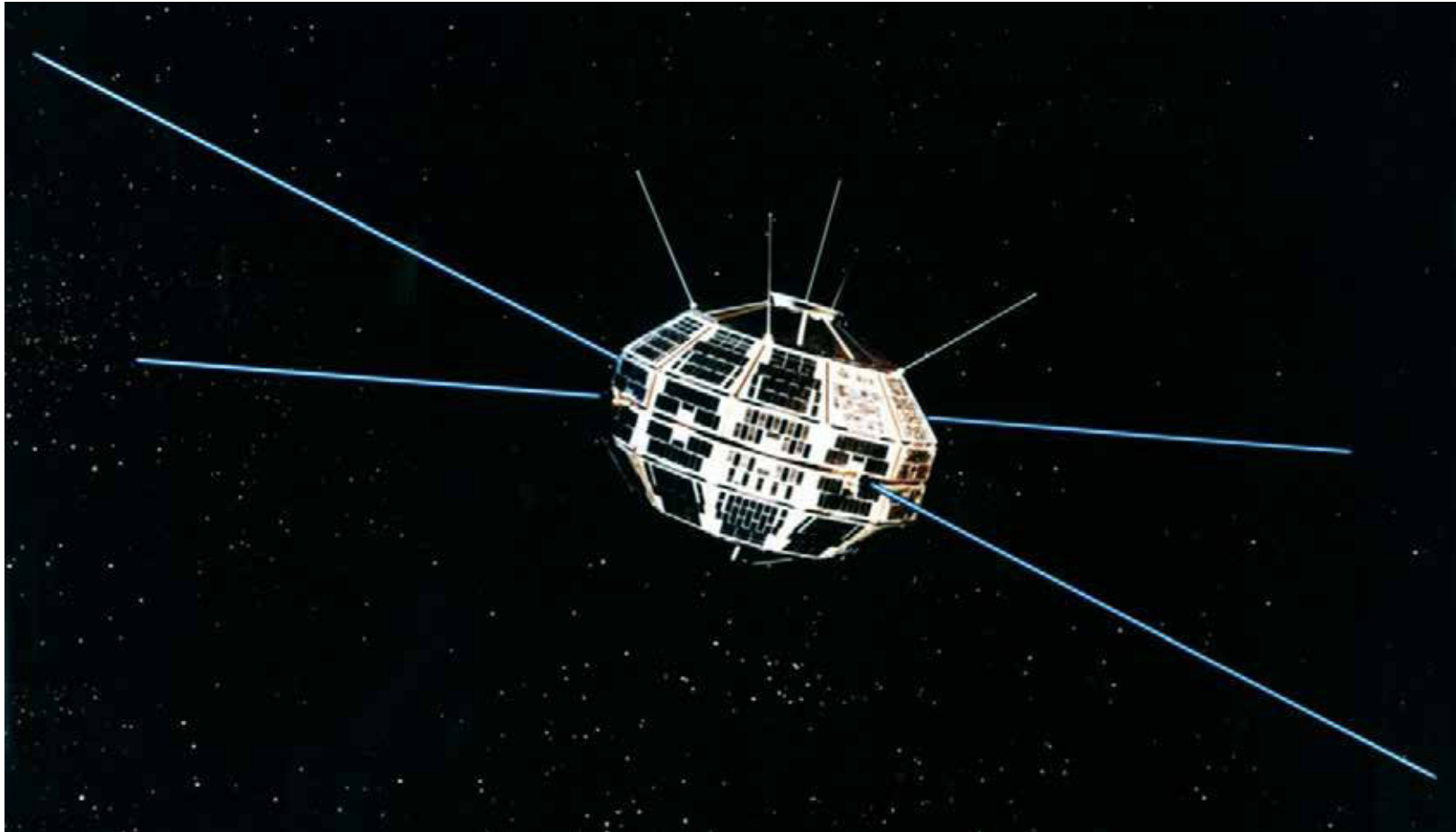

Figure A-1 Alouette-1

*Note.* From Canadian Space Agency, 2008, *Alouette I and II*. Retrieved October 27, 2008, from [http://www.space.gc.ca/asc/app/gallery/results2.asp?session=&image\\_id=alouette](http://www.space.gc.ca/asc/app/gallery/results2.asp?session=&image_id=alouette)

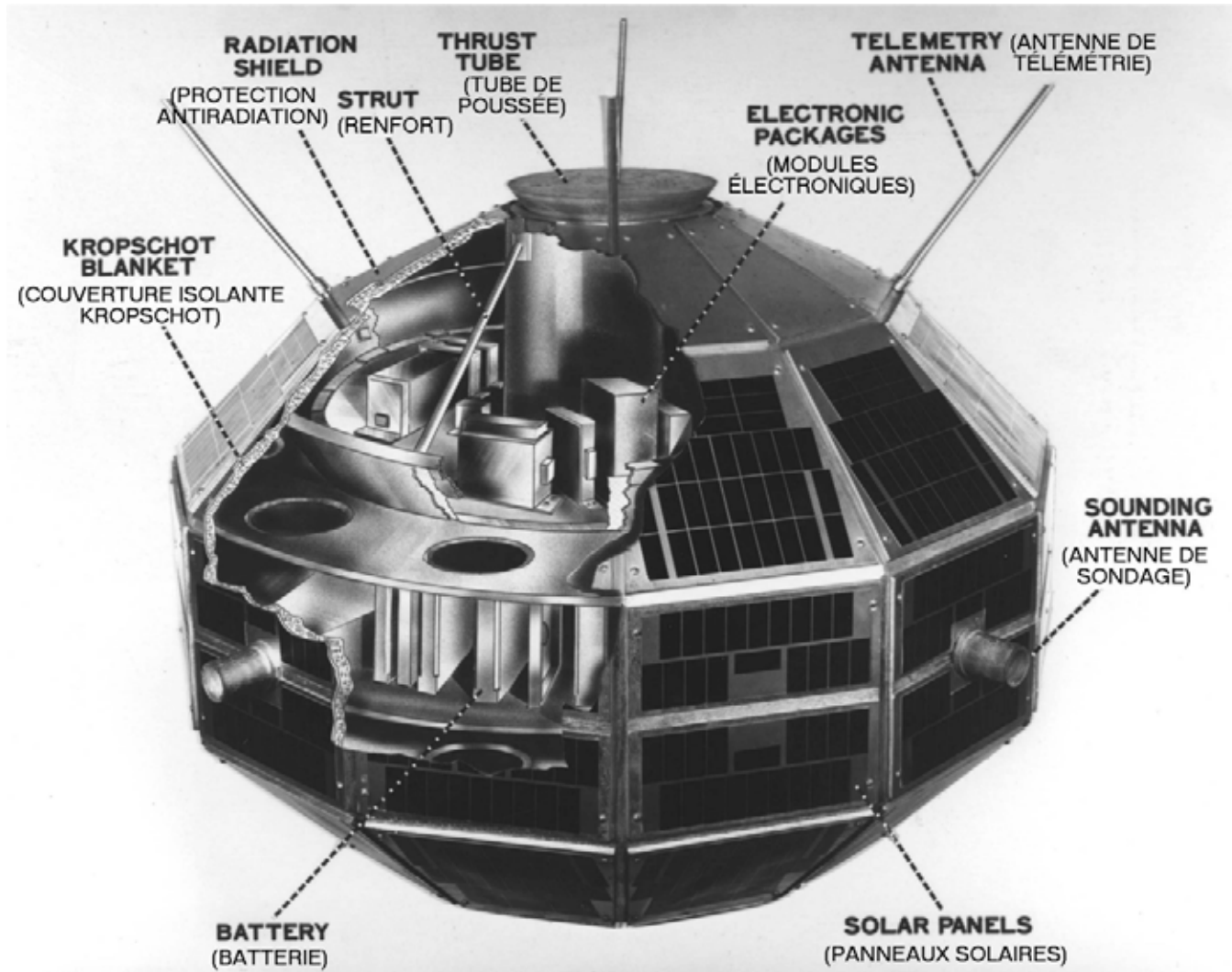

Figure A-2 Alouette-1 Revealed

*Note.* From Canadian Space Agency, 2008, *Alouette I and II*. Retrieved October 27, 2008, from [http://www.space.gc.ca/asc/app/gallery/results2.asp?session=&image\\_id=jhchapman-03](http://www.space.gc.ca/asc/app/gallery/results2.asp?session=&image_id=jhchapman-03)

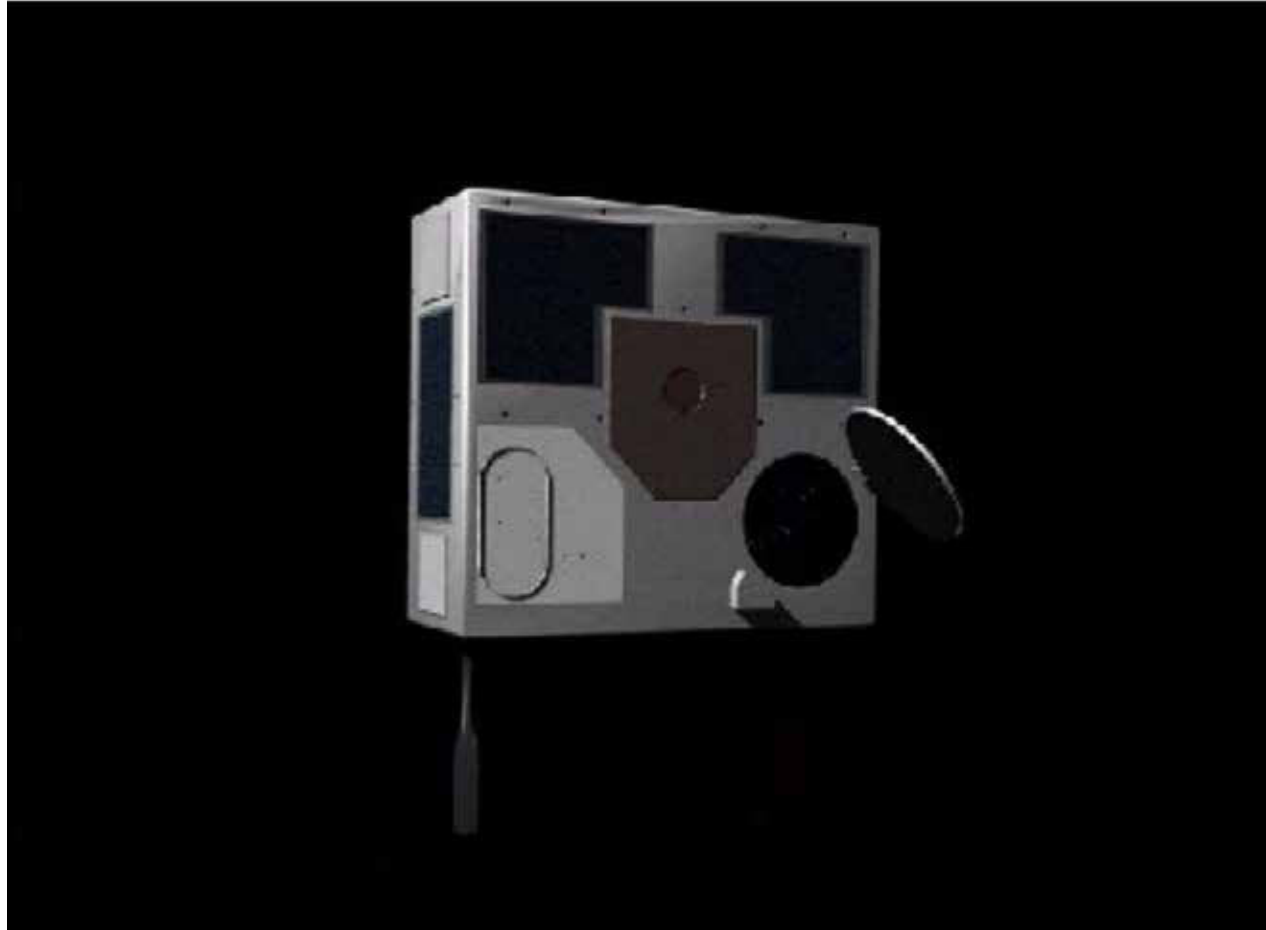

Figure B-1 MOST With Telescope Protective Door Open

*Note.* From "MOST: Canada's First Space Telescope", 2008, *Galleries*. Retrieved October 27, 2008, from <http://www.astro.ubc.ca/MOST/galleries.html#movies>

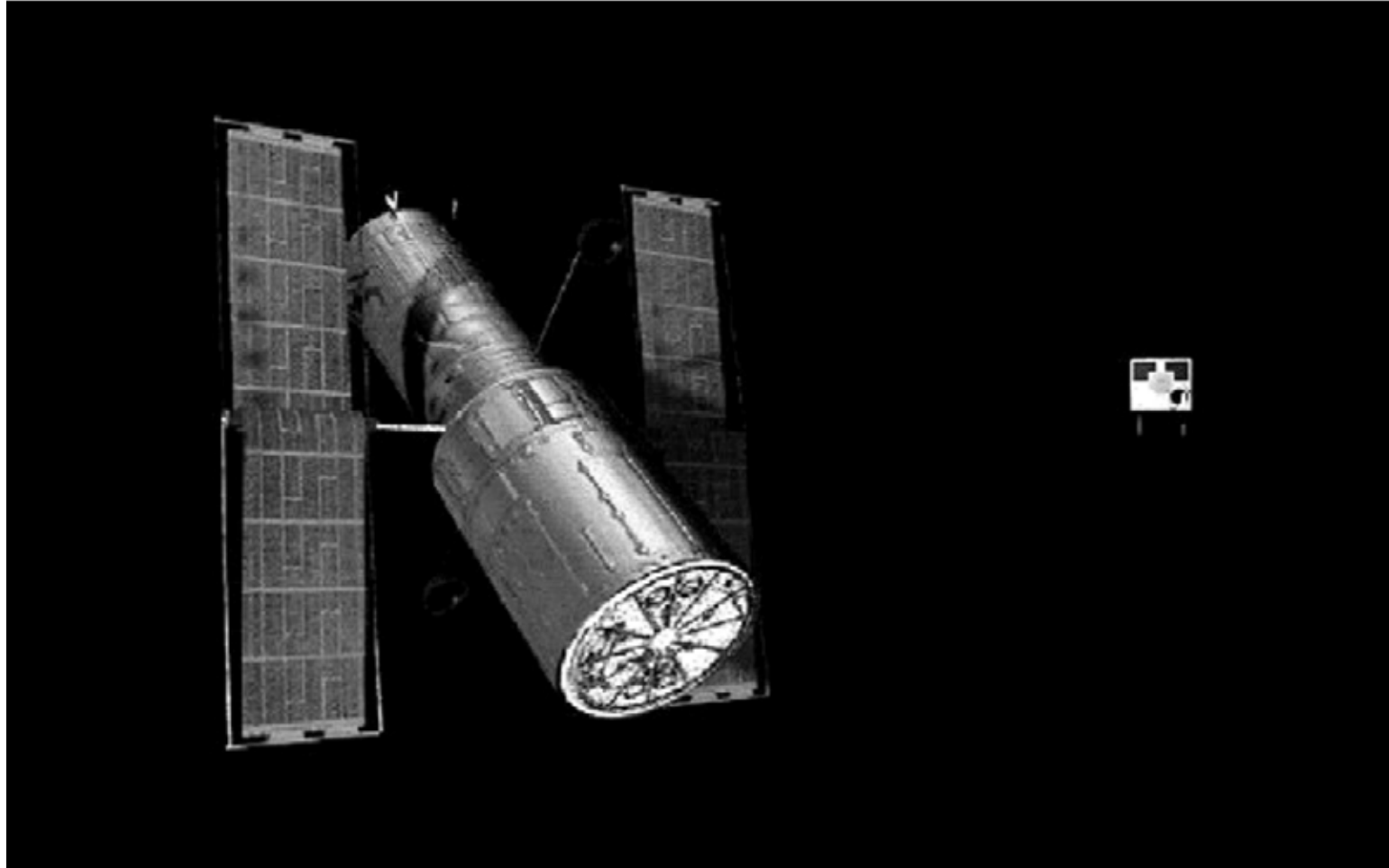

Figure B-2 The Hubble and the Humble to Scale

*Note.* From "MOST: Canada's First Space Telescope", 2008, *Galleries*. Retrieved October 27, 2008, from <http://www.astro.ubc.ca/MOST/galleries.html#movies>

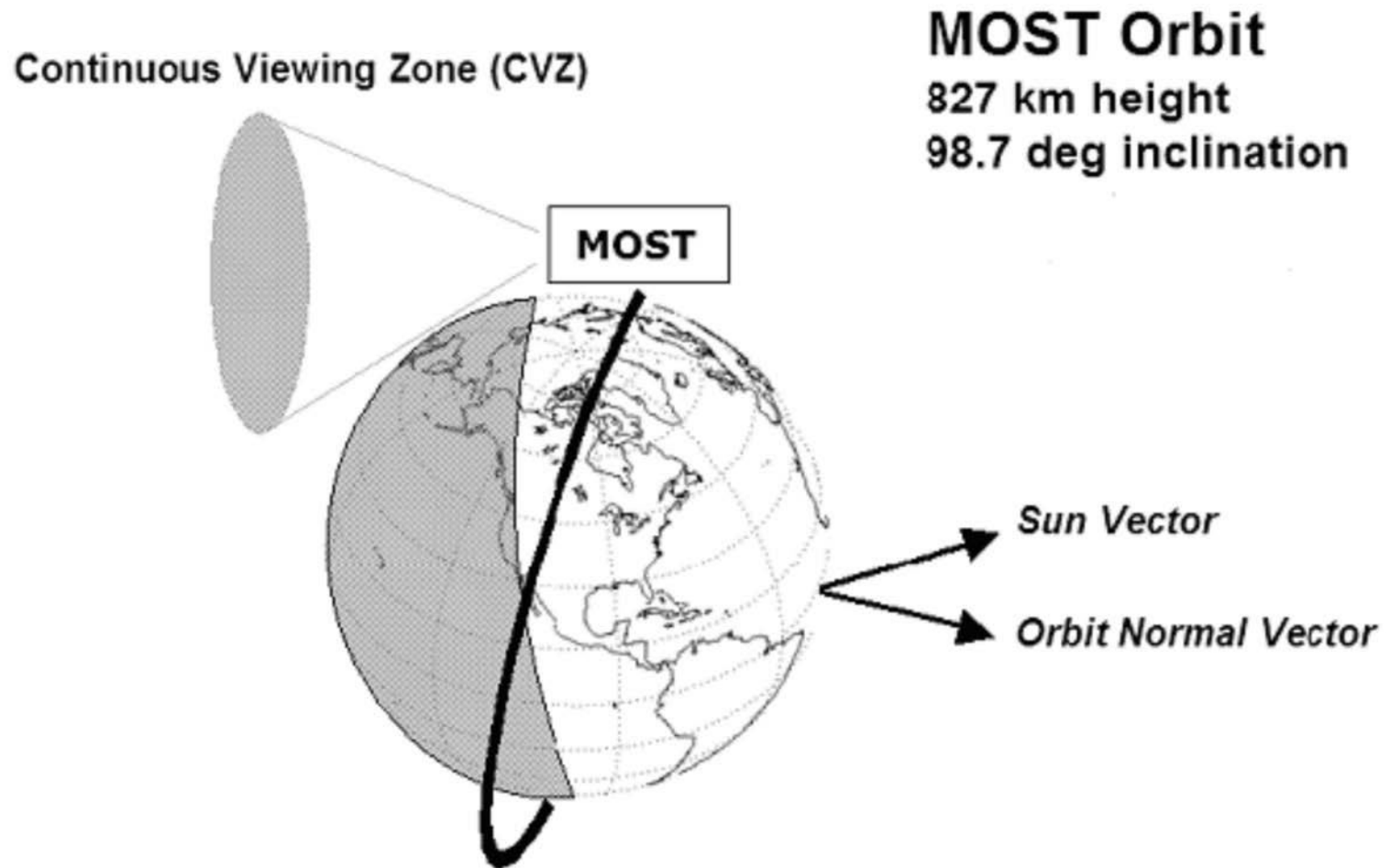

Figure B-3 MOST's Sun-Synchronous Polar Orbit

*Note.* From *The MOST Asteroseismology Mission: Ultraprecise Photometry from Space*, 2003, by G. Walker, J. Matthews, R. Kuschnig, & R. Johnson. Retrieved October, 20, 2008, from <http://www.astro.ubc.ca/MOST/papers/walker.pdf>

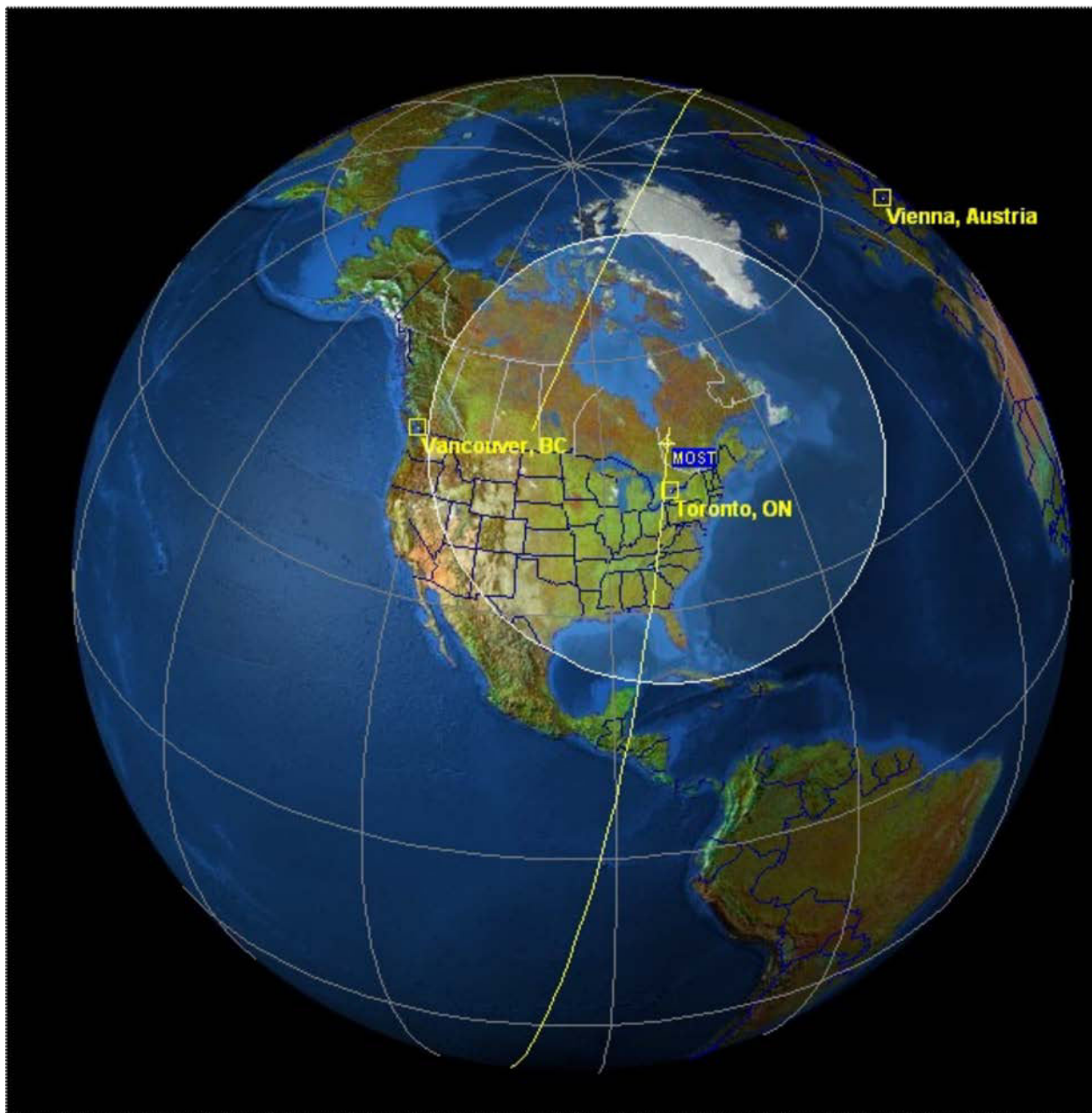

Figure B-4 MOST and Its Ground Stations

*Note.* From "MOST: Canada's First Space Telescope", 2008, *Galleries*.  
Retrieved October 27, 2008, from <http://www.astro.ubc.ca/MOST/galleries.html>



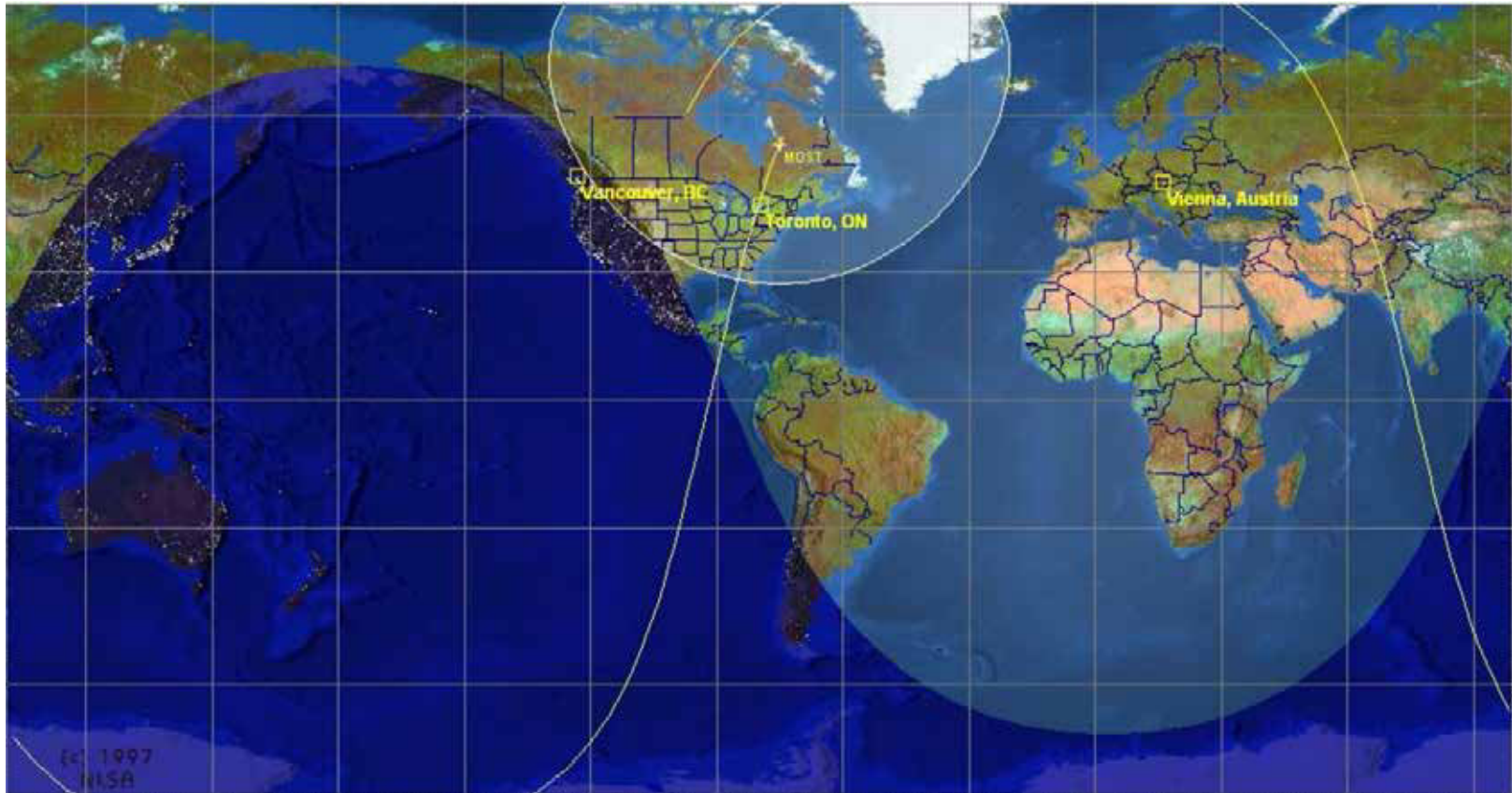

Figure B-5 MOST in Orbit

*Note.* From "MOST: Canada's First Space Telescope", 2008, *Galleries*. Retrieved October 27, 2008, from <http://www.astro.ubc.ca/MOST/galleries.html>

THIS PAGE INTENTIONALLY LEFT BLANK

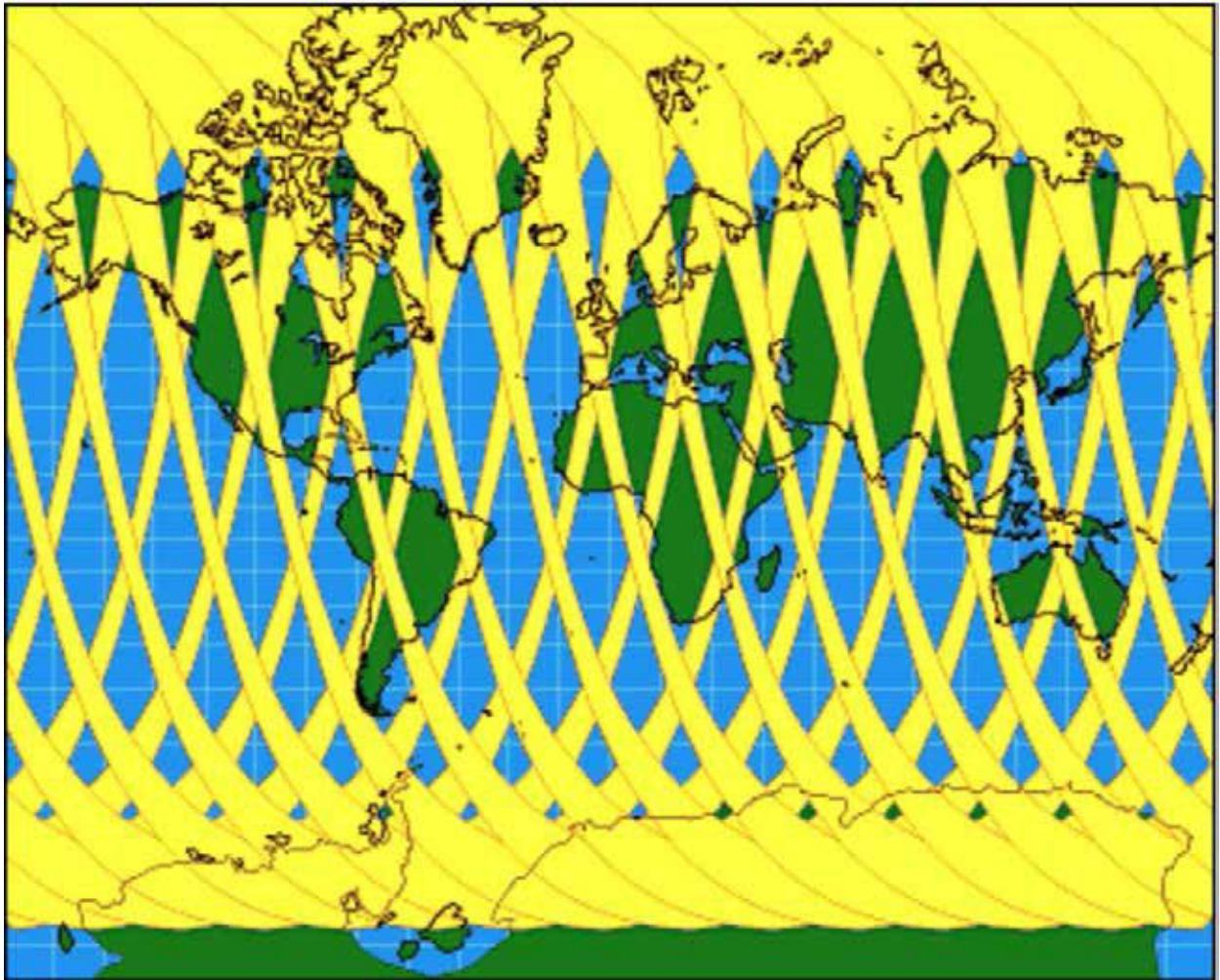

Figure C-1 RADARSAT Coverage

*Note.* From Natural Resources Canada, 2008, "Canada Centre for Remote Sensing", *RADARSAT-1 Overview*. Retrieved October 27, 2008, from [http://www.ccrs.nrcan.gc.ca/radar/spaceborne/radarsat1/specs/index\\_e.php](http://www.ccrs.nrcan.gc.ca/radar/spaceborne/radarsat1/specs/index_e.php)

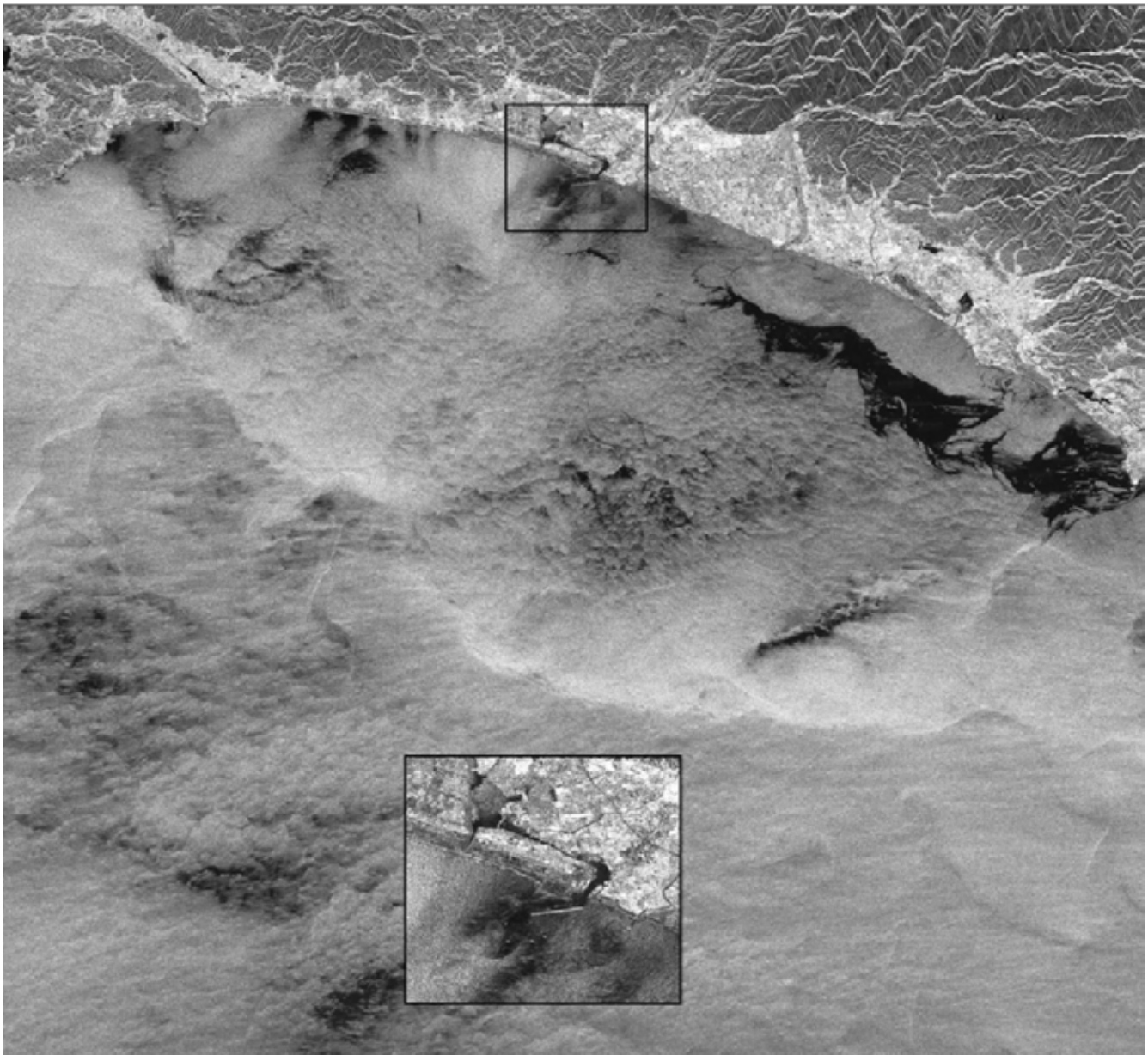
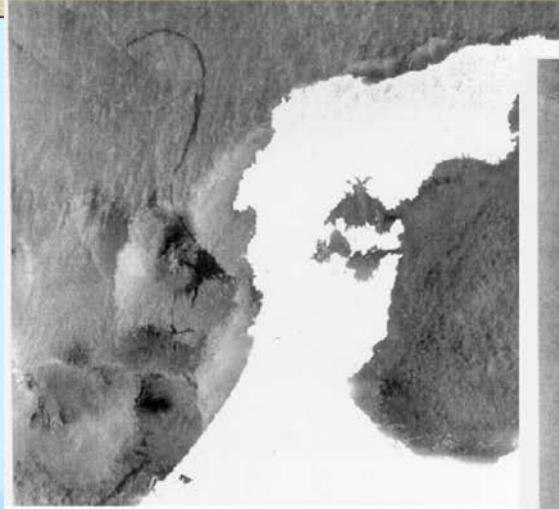

Figure C-2 RADARSAT View of the 1997 Nakhodka Oil Spill in Japan

*Note.* From "Satellite Operations", 2002, by A. Mahmood, *RADARSAT-1 Disaster Watch Program*. Retrieved October 27, 2008, from [http://www.unescap.org/icstd/SPACE/documents/RWDM\\_Bangkok/Acrobat/CANADA-RADARSAT1-Mahmood.pdf](http://www.unescap.org/icstd/SPACE/documents/RWDM_Bangkok/Acrobat/CANADA-RADARSAT1-Mahmood.pdf)



## Satellite observed oil slicks after the *Nakhodka* oil spill in the Japan Sea



(c) CSA 1997

**January 10-11, 1997**

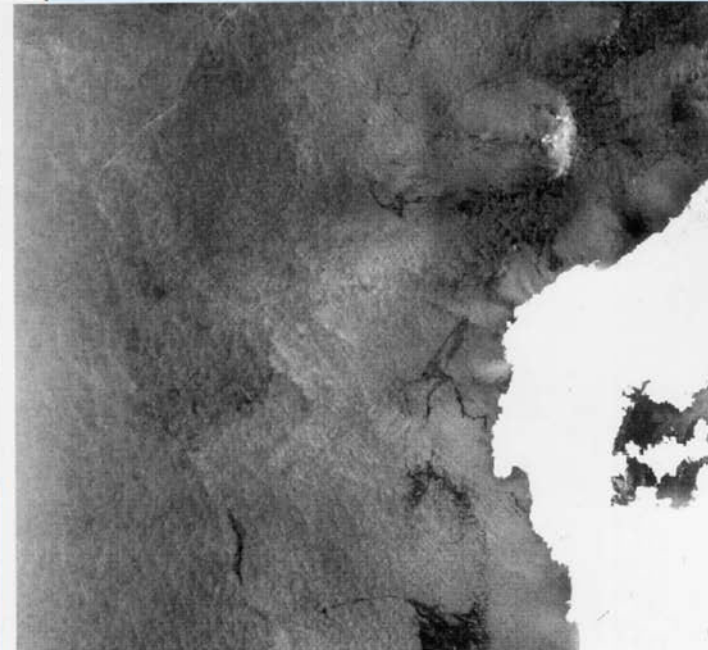

(c) CSA 1997

*Source: Japan Remote Sensing Agency, Canadian RADARSAT data*

Figure C-3 Nakhodka Oil Spill Images

*Note.* From Japan Society for the Promotion of Sciences, 2000, "Asian Science Seminar", *Transport of Pollutants in the Air and the Sea of East Asia*. Retrieved October 27, 2008, from [http://omg.riam.kyushu-u.ac.jp/~vsm/html/Lecture\\_20001025.pps](http://omg.riam.kyushu-u.ac.jp/~vsm/html/Lecture_20001025.pps)

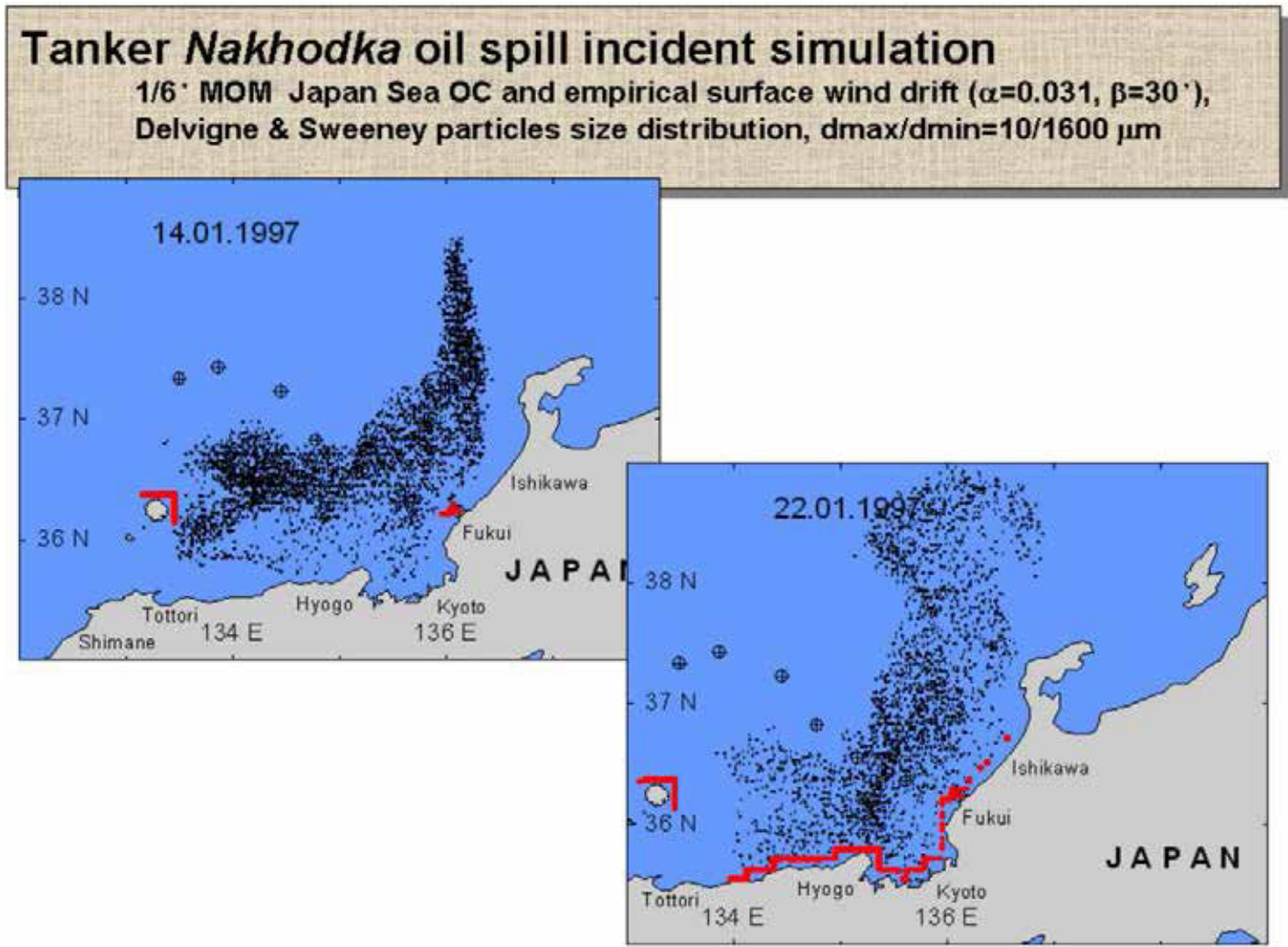

Figure C-4 Computer Simulation of the Nakhodka Oil Spill

Note. From Japan Society for the Promotion of Sciences, 2000, "Asian Science Seminar", *Transport of Pollutants in the Air and the Sea of East Asia*. Retrieved October 27, 2008, from [http://omg.riam.kyushu-u.ac.jp/~vsm/html/Lecture\\_20001025.pps](http://omg.riam.kyushu-u.ac.jp/~vsm/html/Lecture_20001025.pps)



**ROYAL CANADIAN AIR CADETS  
PROFICIENCY LEVEL FOUR  
INSTRUCTIONAL GUIDE**



**SECTION 3**

**EO C440.01 – DESCRIBE MODEL ROCKETRY**

---

Total Time: 60 min

---

**PREPARATION**

---

**PRE-LESSON INSTRUCTIONS**

Resources needed for the delivery of this lesson are listed in the lesson specification located in A-CR-CCP-804/PG-001, *Proficiency Level Four Qualification Standard and Plan*, Chapter 4. Specific uses for said resources are identified throughout the instructional guide within the TP for which they are required.

Review the lesson content and become familiar with the material prior to delivering the lesson.

Create slides of the figures located at Attachments A.

Photocopy the handouts located at Attachments B and C for each cadet.

**PRE-LESSON ASSIGNMENT**

Nil.

**APPROACH**

An interactive lecture was chosen for this lesson to present basic information on model rocketry, and summarize the teaching points.

---

**INTRODUCTION**

---

**REVIEW**

Nil.

**OBJECTIVES**

By the end of this lesson the cadet shall be expected to describe the parts of a model rocket, the flight profile of a model rocket, and model rocket safety.

**IMPORTANCE**

It is important that the cadets know the parts of a model rocket, how a model rocket engine works, and model rocket safety, so they can plan the flight profile of their model rocket.

**Teaching Point 1****Describe the parts of a model rocket engine.**

Time: 15 min

Method: Interactive Lecture

Model rocket engines are composed of six basic parts:

- engine case,
- clay nozzle,
- black powder propellant,
- delay composition,
- ejection charge, and
- igniter.



Show the cadets the slide of Figure A-1 located at Attachment A.

**ENGINE CASE**

The case keeps the engine together and under the correct pressure. Without pressure, the fuel will burn without producing efficient thrust. If the case is not strong enough and the pressure gets too high, the engine will explode. The engine case can be made of paper, cardboard, plastic or aluminum. Paper cases are rolled from paper to form a solid tube of cardboard.

**CLAY NOZZLE**

The nozzle directs the gas that is formed by the reaction of the oxidant out the back of the rocket. The nozzle is formed so the gasses are accelerated as they pass through the nozzle and provide efficient thrust. Nozzles can be made of clay, ceramic or metal.

**PROPELLANT**

The propellant is the substance that actually burns or oxidizes. This reaction between the oxidizer and fuel generates gas and heat, which provides the power for the rocket.

Model rocket engines use black powder as both the oxidizer and fuel. The black powder is mixed with other components and is packed or molded into a solid form inside the engine case. These engines are easy to use and safe to transport because the components do not require special containers and the engines are very unlikely to ignite accidentally.

The propellant burns at a prescribed rate and propels the rocket through the atmosphere. The propellant burns stronger at takeoff and has less force towards the end of the power stage. This can be represented in a time-to-thrust graph.



Show the cadets the slide of Figure A-2 located at Attachment A.



Average thrust is calculated by dividing the total impulse by the duration of the propellant burning.

Depending on the depth of the igniter hole, rocket engines can burn two different ways. Shallow holes in the propellant result in end burn where the propellant burns from one end to the other. Engines requiring more lift use deep holes in the propellant causing the fuel to burn quickly resulting in extra lift earlier on in the flight.



Show the cadets the slide of Figure A-3 located at Attachment A.

Model rocket engines are labelled with a three-part classification code (B6-4) that describes the performance parameters of the engine. This code must be understood in order to choose the proper engine for the model rocket. The first part of the engine code is a letter designating the motor's total impulse class (the "B" in B6-4). Engine size is determined by the amount of propellant and case size. As engine size increases, the letter in the engine code changes to the next letter of the alphabet, and the engine is twice as powerful as the previous letter (eg, A series engines have 1.26 to 2.5 Newton seconds of force and B series engines 2.5 to 5 Newton seconds of force). Total impulse is the total power the engine produces. Total impulse is a measure of the momentum change the engine can impart to the rocket, measured in Newton-seconds. An engine with greater total impulse can lift a rocket higher and faster, and can lift heavier rockets, than an engine with lower total impulse. The table below gives the total impulse ranges and typical rocket performance for each class.



Show the cadets the slide of Figure A-4 located at Attachment A.

## THE DELAY COMPOSITION

After the propellant has burned entirely the delay composition starts burning to allow the rocket to coast to the highest point in the flight or the apogee. As the delay composition burns, it emits smoke, allowing tracking of the rocket in its flight. Delay composition burn times can vary from 3–10 seconds and are linked to the weight and size characteristics of the rocket. A heavy and slow rocket would require a shorter burn time, as it would not be moving through the air as fast as a smaller lighter rocket with the same code engine. It is important to calculate the delay as deployment of the parachute or streamer during high speed before or after apogee can result in destruction of the parachute or streamer.

## EJECTION CHARGE

The parachute or streamer is deployed by the ejection charge. This black powder charge ignites immediately after the delay composition has completed burning. It pushes the parachute or streamer and nose cone out of the front of the rocket.

## IGNITER

The igniter uses an electrically activated fuse to ignite the propellant. An electrical source supplies power to the control panel and control switch. Switching on the power at the control switch causes the igniter to burn, which ignites the propellant.

---

## CONFIRMATION OF TEACHING POINT 1

### QUESTIONS:

- Q1. The engine case of a model rocket engine can be made from what materials?
- Q2. Why does a model rocket require an ejection charge?
- Q3. How does an igniter work?

### ANTICIPATED ANSWERS:

- A1. Paper, cardboard, plastic or aluminum.
- A2. To deploy the parachute or streamer.
- A3. Switching on the power at the control switch causes the igniter to burn, which ignites the propellant.

---

## Teaching Point 2

## Describe the parts of a model rocket.

Time: 10 min

Method: Interactive Lecture

---

A model rocket consists of the following parts:

- nose cone,
- body tube,
- fins,
- launch lug,
- engine stop,
- engine restraint,
- shock cord, and
- parachute.



Show the cadets the slide of Figure A-5 located at Attachment A.

## NOSE CONE

The nose cone helps the rocket cut through the air during flight. It is important that the nose cone be aerodynamic to offer the least resistance when moving through the air. There are several different styles of nose cones, some for specific speeds. The nose cone is fitted to the body tube so that it can easily be ejected to deploy the parachute. It has an attachment point on one end for the shock cord and can be made from plastic, wood, Styrofoam™, fiberglass or carbon fibre.

## **BODY TUBE**

All the parts of the rocket attach to or are contained within the body tube. The tube must be rigid to maintain its form during flight and can be made of cardboard, plastic, fibreglass or carbon fibre.

## **FINS**

The fins help stabilize the rocket during flight. They are usually placed near the engine and are usually made of balsa wood, plastic, cardboard, fibreglass or carbon fibre. They must be attached securely and accurately to the body tube as any misalignment will result in an unpredictable flight. Fins on a rocket should be handled with care to avoid damage and misalignment.

## **LAUNCH LUG**

The launch lug guides the rocket off the launch pad for the first metre of flight until the rocket has reached enough speed for the fins to stabilize the rocket. In order to launch the rocket the launch lug is placed on the launch rod of the tower. The lug slides the rocket down the launch rod and is held there until launch. When the launch button is pressed, the rocket engine accelerates the rocket up the launch rod guided by the lug and can quickly achieve over 50 km / h before it leaves the launch rod. The lug can be made of cardboard or metal.

## **ENGINE STOP**

The engine stop prevents the engine from being pushed through the body tube by the engine's thrust. The engine stop is usually made of cardboard.

## **ENGINE RESTRAINT**

The restraint keeps the engine from being ejected out the tail of the rocket by the parachute deploying an explosive charge. Restraints can be a metal strap, screws or strong tape.

Both the engine stop and restraint prevent the effects of Newton's third law: for every action there is an equal and opposite reaction.

## **SHOCK CORD**

The ejection of the parachute must happen when the rocket reaches apogee or the highest point in the flight. The shock cord, made from elastic webbing, absorbs the force of the explosion that ejects the parachute. One end of the shock cord is attached to the nose cone, the other end to the body tube and the parachute is attached to the nose cone or the middle of the shock cord.

## **PARACHUTE**

The descent of the rocket must be controlled to avoid damage to people, property or the rocket. There are several ways to slow the descent of the rocket. The most common is the parachute, which traps air in a canopy to slow the decent. Parachute canopies are made of light flexible sheet material, in the form of a cross or circle. Shroud lines are made of string or cord, with one end attached to the edges of the canopy and the other end of the shroud lines are attached together to the shock cord or nose cone. Parachute sizes and shroud line length are carefully calculated to control the descent. A large parachute will allow the wind to carry the rocket far from the launch tower. A parachute that is too small will cause the rocket to descend too quickly, possibly causing damage to the rocket.

Other forms of descent can be used on different rockets. Streamers can be used with lightweight rockets and act as a drag on the rocket. Free fall can only be used by the lightest rockets and has no additional equipment to slow the rocket. The drag from the rocket's body and fins will slow the rocket. Glide recovery involves attaching a wing to the rocket to allow the rocket to glide to the Earth.

---

## CONFIRMATION OF TEACHING POINT 2

### QUESTIONS:

- Q1. What purpose does the nose cone serve?
- Q2. What does the launch lug do?
- Q3. How do the fins affect the flight of the rocket?

### ANTICIPATED ANSWERS:

- A1. It helps the rocket cut through the air.
- A2. It guides the rocket off the launch pad.
- A3. The fins stabilize the rocket during flight.

---

## Teaching Point 3

## Describe the flight profile of a model rocket.

Time: 10 min

Method: Interactive Lecture

The burn stages of a model rockets engine allow one to predict the flight profile of the rocket. The flight profile of a model rocket consists of six stages:

1. ignition,
2. power,
3. coast / delay,
4. ejection,
5. descent, and
6. landing.

### IGNITION

Ignition is the result of an electrical current lighting from the control panel and launch switch. The actual device that starts the engine burning is the igniter. It looks like a match head with wires coming from the tip. When the electrical current passes through the igniter, it heats up, causing it to burst into flame. This flame is what actually starts the propellant burning in the rocket engine.



Show the cadets the slide of Figure A-6 located at Attachment A.

After ignition, the rocket will leave the launch tower under thrust. The launch tower guides the rocket during low speed to ensure the rocket remains aligned on the prescribed course. The stabilizer fins on the rocket take over as it leaves the launch rod on the tower, usually at around 50 km / h.



Show the cadets the slide of Figure A-7 located at Attachment A.

## POWER

The propellant inside the engine burns quickly. In most engines, the propellant is consumed in less than three seconds, at which point burnout occurs. This means the engine is no longer producing a thrust force. By the time the engine burns out, the rocket has already reached its top speed and begins decelerating. While the rocket may reach hundreds of metres in the air, the burnout location on most rockets is about 15–25 m (50–80 feet) in the air.



Show the cadets the slide of Figure A-8 located at Attachment A.

## COAST / DELAY

When the engine burns out, the rocket may be travelling hundreds of kilometres per hour. The parachute or streamer can be destroyed if it is ejected at this speed. The model will coast upward and lose airspeed as gravity and air friction slow it down. The period of time that starts at engine burnout and ends when the parachute is ejected out of the rocket is called the coast phase. The delay composition is now burning at a prescribed rate and produces smoke. The rocket moves so fast, that it is hard to follow visually and the smoke helps give a visual indication of the location of the rocket.



Show the cadets the slide of Figure A-9 located at Attachment A.

## EJECTION

When the delay composition is done burning, the rocket should be at apogee. As the delay composition finishes burning it ignites the ejection charge. This ejection charge burns quickly, and is directed forward inside the rocket body tube. Its goal is to push off the nose cone, and eject the parachute out of the rocket. Ejection should occur right at apogee when the rocket has reached its slowest speed. Engine selection controls when the ejection charge pushes out the parachute. If the delay composition burns too long, the rocket will arc over, and will eject the chute while the rocket has begun accelerating in free fall descent. If the delay composition burns too quickly, the rocket may still be moving too fast as it has not coasted to its highest point. Ejection of the parachute at any point other than at apogee will result in the rocket and / or parachute being destroyed and the rocket free falling.



Show the cadets the slide of Figures A-10 and A-11 located at Attachment A.

## DESCENT

After the parachute has ejected, it fully inflates, and the rocket begins its descent phase. The rocket drifts slowly to the ground under the canopy of the parachute or drag of the streamer. The wind will affect the descent of the rocket and this will result in the model drifting away from the launch pad. Descent should not be more than 4.5 m / s (15 feet per second) or it is possible to damage the rocket. If the descent is too slow, the rocket will drift farther from the launch pad affecting recovery.

## LANDING

After landing, the rocket should be fully inspected before the next launch. The engine case should be discarded.



Show the cadets the slide of Figure A-12 located at Attachment A.

---

## CONFIRMATION OF TEACHING POINT 3

### QUESTIONS:

- Q1. How is a model rocket tracked during its flight?
- Q2. When is the optimum time during a rocket's flight profile to deploy the parachute or streamer?
- Q3. Why is there a delay or coast phase during the rocket's flight?

### ANTICIPATED ANSWERS:

- A1. The smoke emitted by the delay composition and parachute or streamer can track the flight of a rocket.
- A2. At apogee.
- A3. To allow the rocket to slow down enough to deploy the parachute without destroying it.

---

## Teaching Point 4

## Explain model rocketry safety rules.

Time: 15 min

Method: Interactive Lecture

The hobby of model rocketry originated at the dawn of the space age in the late 1950s. Seeing space boosters carry the first artificial satellites into Earth's orbit inspired many enthusiastic young people to try to emulate the rocket pioneers by building their own rockets. Unfortunately, these homemade rockets involved stuffing flammable chemicals into metal pipes, very often with tragic results. Newspapers told stories of fingers and eyes lost and all too frequently of lives lost.

What was needed was a safe alternative that would allow young people to experience constructing and launching their own rockets and provide them with the opportunity to explore the science of rocketry.

Several companies developed engines that did not explode and provided a safe flight for model rockets. This style of engine is still in use today.

Safety is important when flying model rockets. It is impossible to get out of the way of a rocket going over 400 km / h. The flame produced by the engine is extremely hot and capable of inflicting serious burns or setting objects on fire. Therefore, there are rules in place for launching rockets. The Canadian Aviation Regulations (CARs) and the Canadian Association of Rocketry (CAR) have rules for launching model rockets.



Distribute photocopies of Attachments B and C to the cadets.

The CARs establish that a model rocket equipped with a model rocket engine will not have a total impulse exceeding 160 Newton-seconds and will not exceed 1500 grams, and will be equipped with a parachute or recovery device capable of retarding its descent. Anything above these parameters requires a high power model rocketry license and permission to fly from Transport Canada.

CAR model rocket rules cover launch site size, model rocket construction and launch procedures.

---

#### **CONFIRMATION OF TEACHING POINT 4**

##### **QUESTIONS:**

- Q1. Why is safety important when launching model rockets?
- Q2. Who establishes the rules for model rocketry in Canada?
- Q3. What is the maximum weight of a model rocket?

##### **ANTICIPATED ANSWERS:**

- A1. There are potential dangers from the rocket engine's flame and the high velocity of the rocket.
- A2. Canadian Association of Rocketry.
- A3. 1500 grams.

---

#### **END OF LESSON CONFIRMATION**

##### **QUESTIONS:**

- Q1. When do the fins help guide the rocket during its flight?
- Q2. How are rocket engines classified?
- Q3. How do we slow a rocket's descent?
- Q4. What purpose does the nose cone serve?
- Q5. What is apogee?

##### **ANTICIPATED ANSWERS:**

- A1. When the rocket achieves over 50 km / h or when it leaves the launch rod.
- A2. By letter, each successive letter doubles the force of the engine.
- A3. By using a parachute or streamer.
- A4. It helps the rocket cut through the air.
- A5. The highest point of a flight.

---

## CONCLUSION

---

### HOMEWORK / READING / PRACTICE

Nil.

### METHOD OF EVALUATION

Nil.

### CLOSING STATEMENT

Model rocketry is a fun and exciting sport. It is important to know the parts of a model rocket, how a model rocket engine works, model rocket safety, and how to plan the flight profile of a model rocket, to be able to fly model rockets safely.

### INSTRUCTOR NOTES / REMARKS

Cadets who have completed Advanced Aerospace summer training may assist with this instruction.

Cadets who are qualified Advanced Aviation may assist with this instruction.

---

## REFERENCES

---

C3-162 Beach, T. (1993). *Model rocketry technical manual*. Retrieved October 10, 2007, from <http://www.estesrockets.com/assets/downloads/roeketrytechniques.pdf>

C3-163 Cannon, R. L. (1999). *A learning guide for model rocket launch systems*. Retrieved October 10, 2007, from <http://www.estesrockets.com/assets/downloads/launchsystemguide.pdf>

C3-259 ISBN 978-0471472421 Stine, G. H. (2004). *Handbook of model rocketry*. Toronto, ON: John Wiley & Sons.



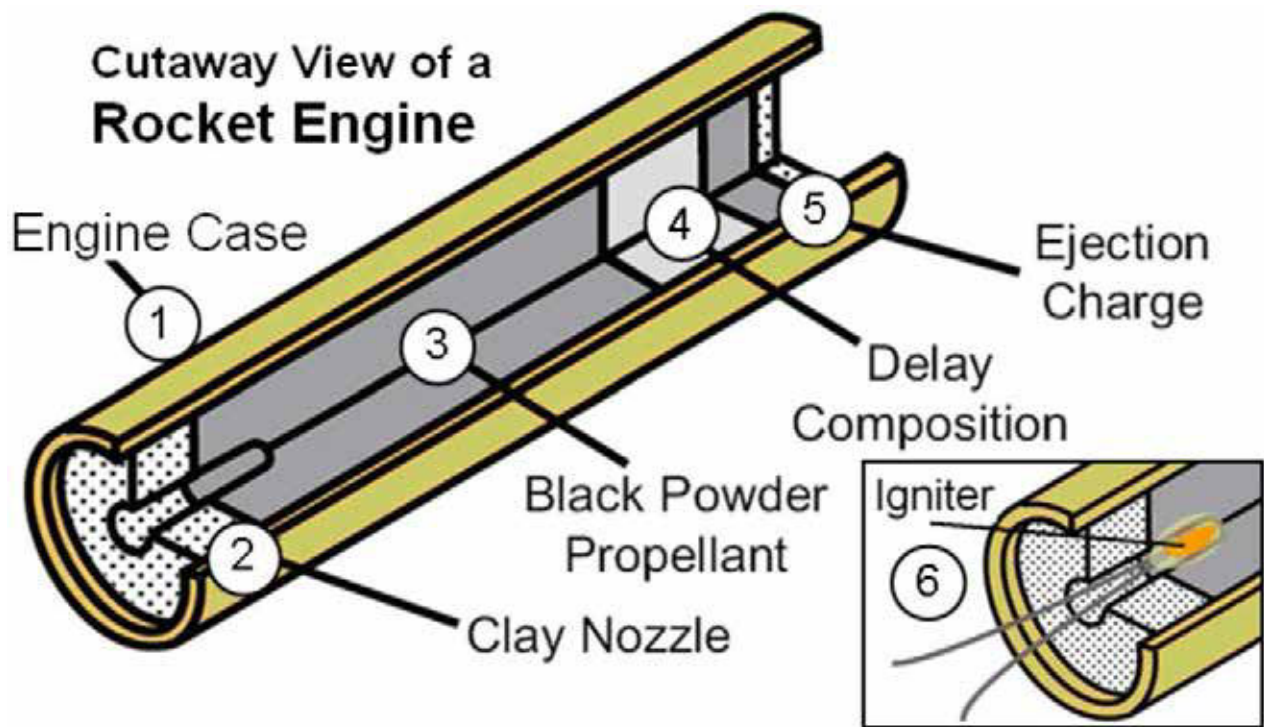

Figure A-1 Cutaway View of a Rocket Engine

Note. From "Apogee Peak of Flight Newsletter", 2003, *How Black Powder Rocket Motors Work*. Retrieved November 16, 2007, from <http://www.apogeerockets.com/educator/downloads/newsletter114.pdf>

## TIME/THRUST CURVES

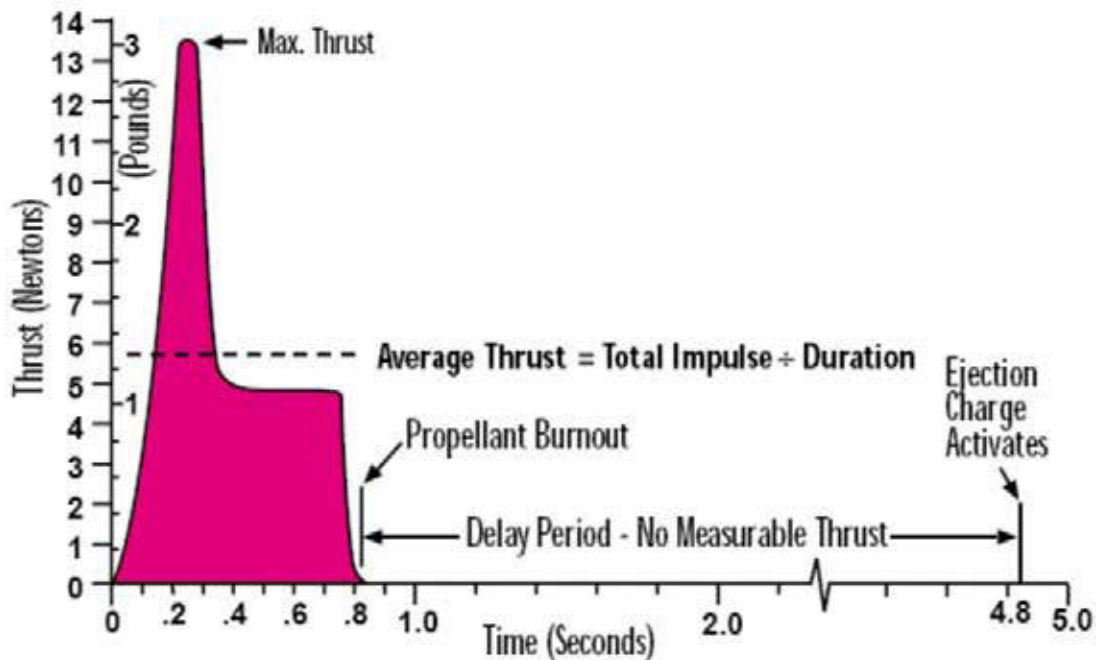

Figure A-2 Time / Thrust Curves

Note. From "Estes Rocketry", 1993, by T. Beach, 2003, *Model Rocketry Technical Manual*. Retrieved October 10, 2007, from <http://www.estesrockets.com/assets/downloads/rocketrytechniques.pdf>

## ENGINE CODING FOR QUICK-N-EASY IDENTIFICATION

1. Label color indicates recommended use of the engine.
  - a. Green ..... Single Stage rockets
  - b. Purple ..... Upper Stage or Single Stage, if used in very light rockets
  - c. Red ..... \*Booster and intermediate stages of multi-stage rockets
  - d. Black ..... \*Special plugged engines for R/C gliders

\*These contain no delay or ejection charge.
2. Code designation stamped on the engine gives useful and important information on its performance capabilities.
  - a. This portion indicates total impulse or total power produced by the engine.
  - b. This portion shows the engine's average thrust in Newtons and helps you choose the proper engine for your rocket's flight.
  - c. This number gives you the delay in seconds between burnout and ejection charge. It lets you choose the engine with the delay time you want for any flight.

TYPE AND PRIMARY USE

**B6-2 SINGLE STAGE**



Figure A-3 Model Rocket Engine Codes

Note. From "Estes Rocketry", 1993, by T. Beach, 2003, *Model Rocketry Technical Manual*. Retrieved October 10, 2007, from <http://www.estesrockets.com/assets/downloads/rocketrytechniques.pdf>

## TOTAL IMPULSE CLASSIFICATION

Code	Pound-Seconds	Newton-Seconds
1/2A	0.14 - 0.28	0.625 - 1.25
A	0.28 - 0.56	1.26 - 2.50
B	0.56 - 1.12	2.51 - 5.00
C	1.12 - 2.24	5.01 - 10.00
D	2.24 - 5.00	10.01 - 20.00

Figure A-4 Impulse Classification for Model Rocket Engines

*Note.* From "Estes Rocketry", 1993, by T. Beach, 2003, *Model Rocketry Technical Manual*. Retrieved October 10, 2007, from <http://www.estesrockets.com/assets/downloads/roeketrytechniques.pdf>

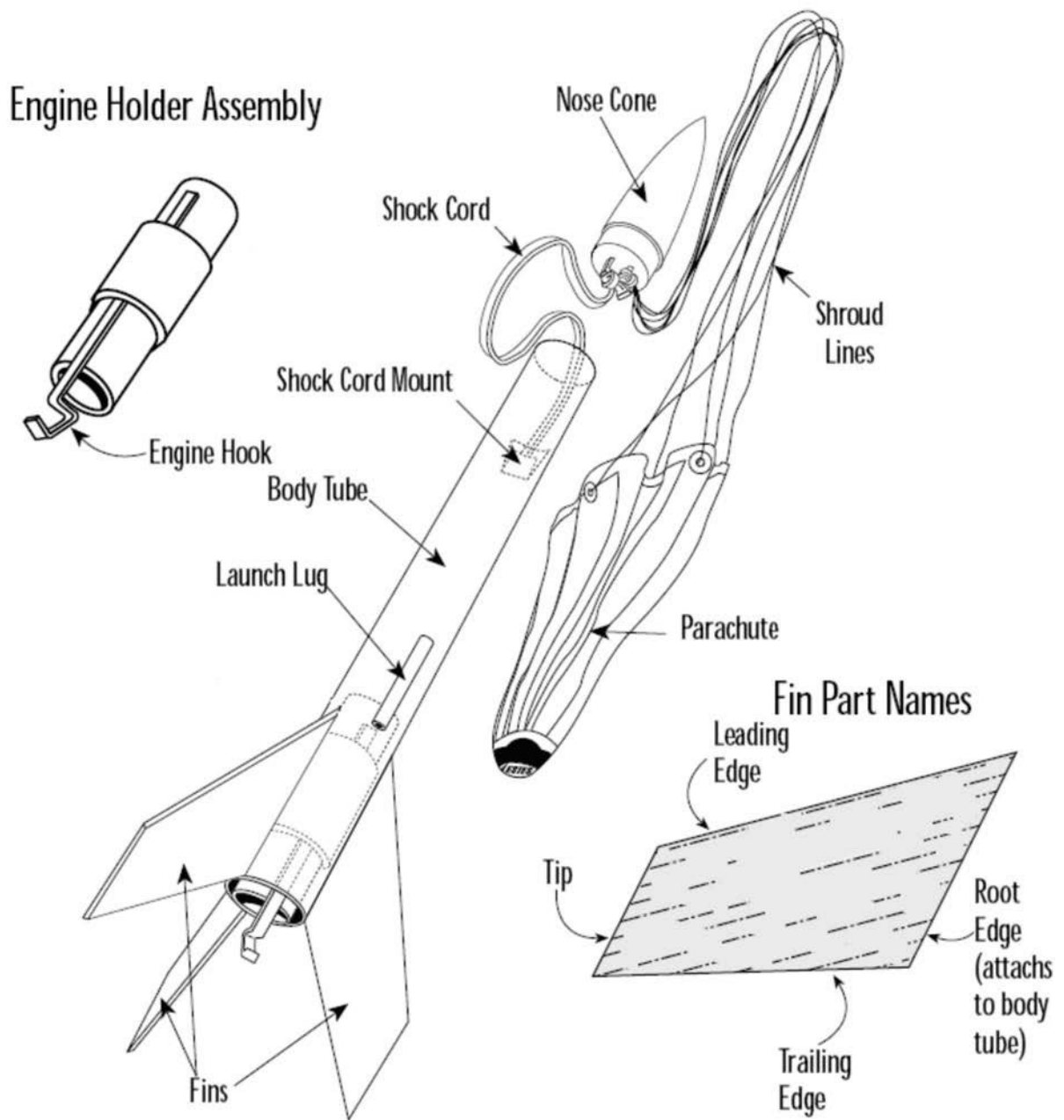

Figure A-5 Parts of a Model Rocket

Note. From "Estes Rocketry", 1993, by T. Beach, 2003, *Model Rocketry Technical Manual*. Retrieved October 10, 2007, from <http://www.estesrockets.com/assets/downloads/rocketrytechniques.pdf>

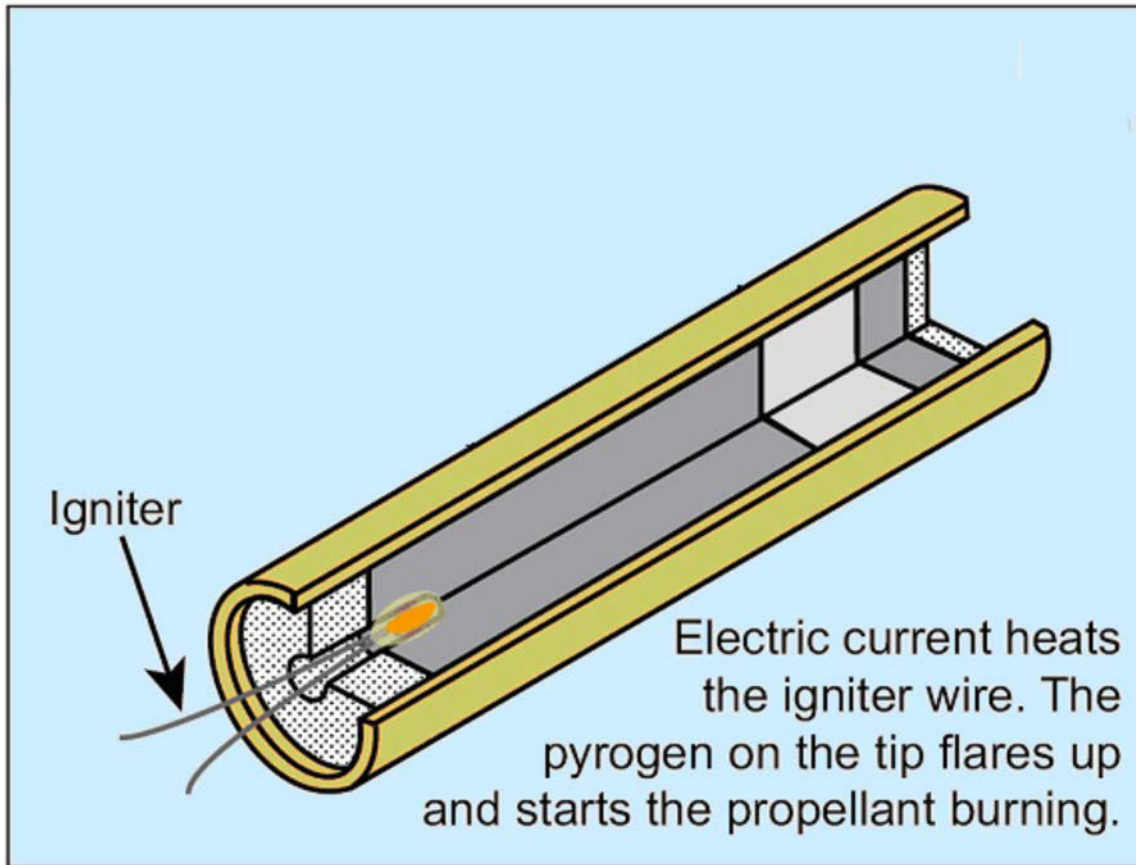

Figure A-6 The Igniter

Note. From "Apogee Peak of Flight Newsletter", 2003, *How Black Powder Rocket Motors Work*. Retrieved November 16, 2007, from <http://www.apogeerockets.com/educator/downloads/newsletter114.pdf>

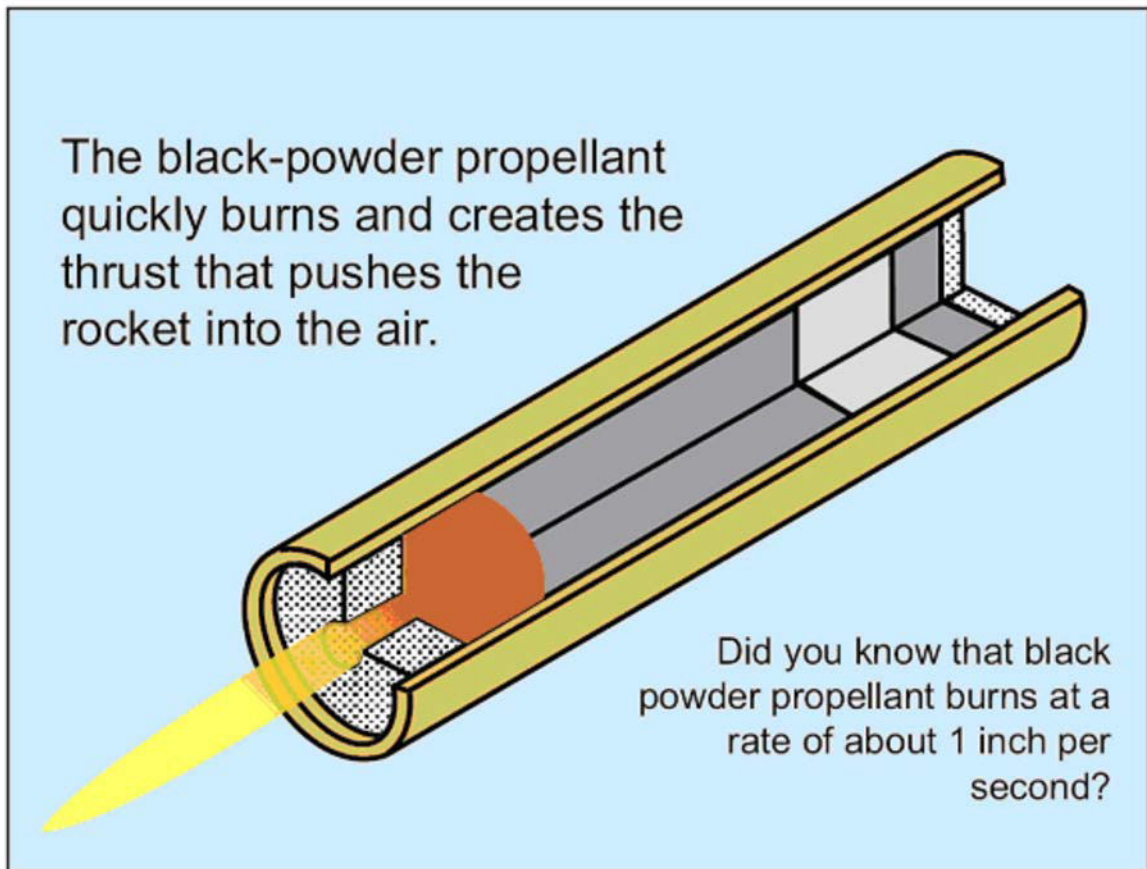

Figure A-7 The Propellant Ignited

*Note.* From "Apogee Peak of Flight Newsletter", 2003, *How Black Powder Rocket Motors Work*. Retrieved November 16, 2007, from <http://www.apogeerockets.com/educator/downloads/newsletter114.pdf>

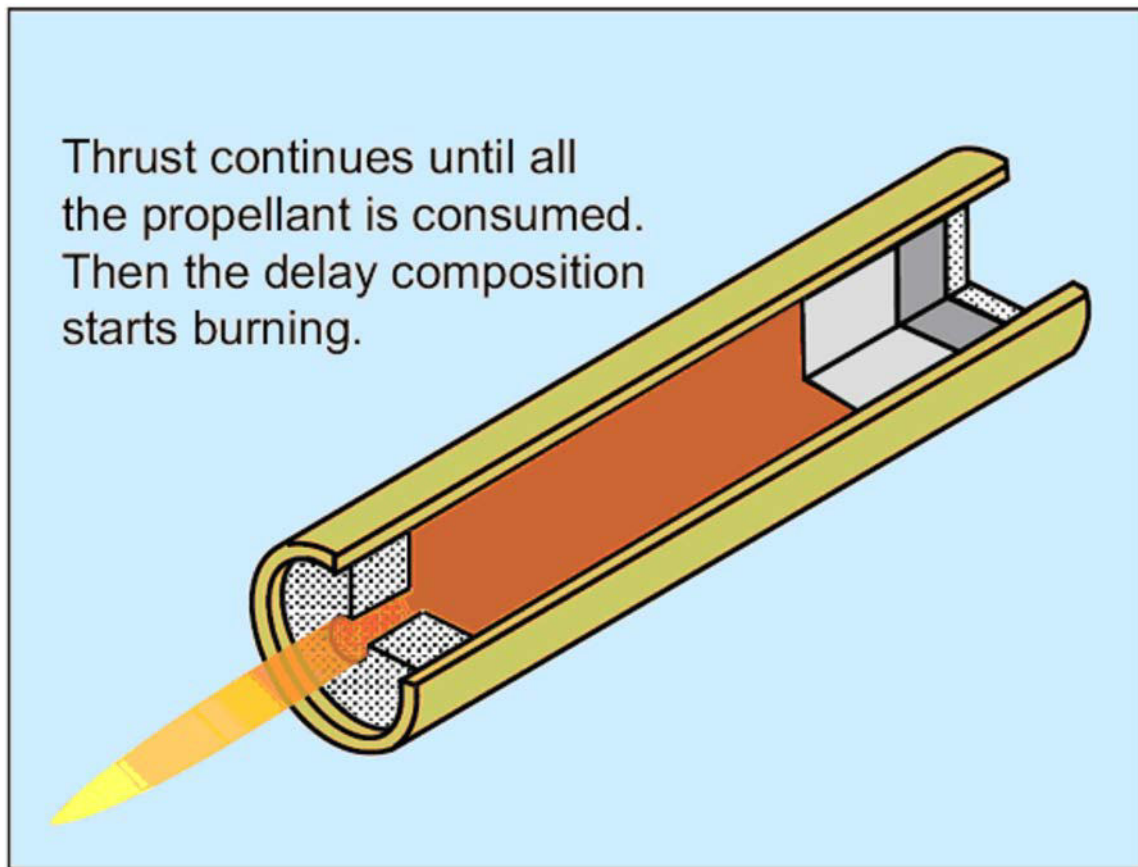

Figure A-8 Thrust Phase

Note. From "Apogee Peak of Flight Newsletter", 2003, *How Black Powder Rocket Motors Work*. Retrieved November 16, 2007, from <http://www.apogeerockets.com/educator/downloads/newsletter114.pdf>



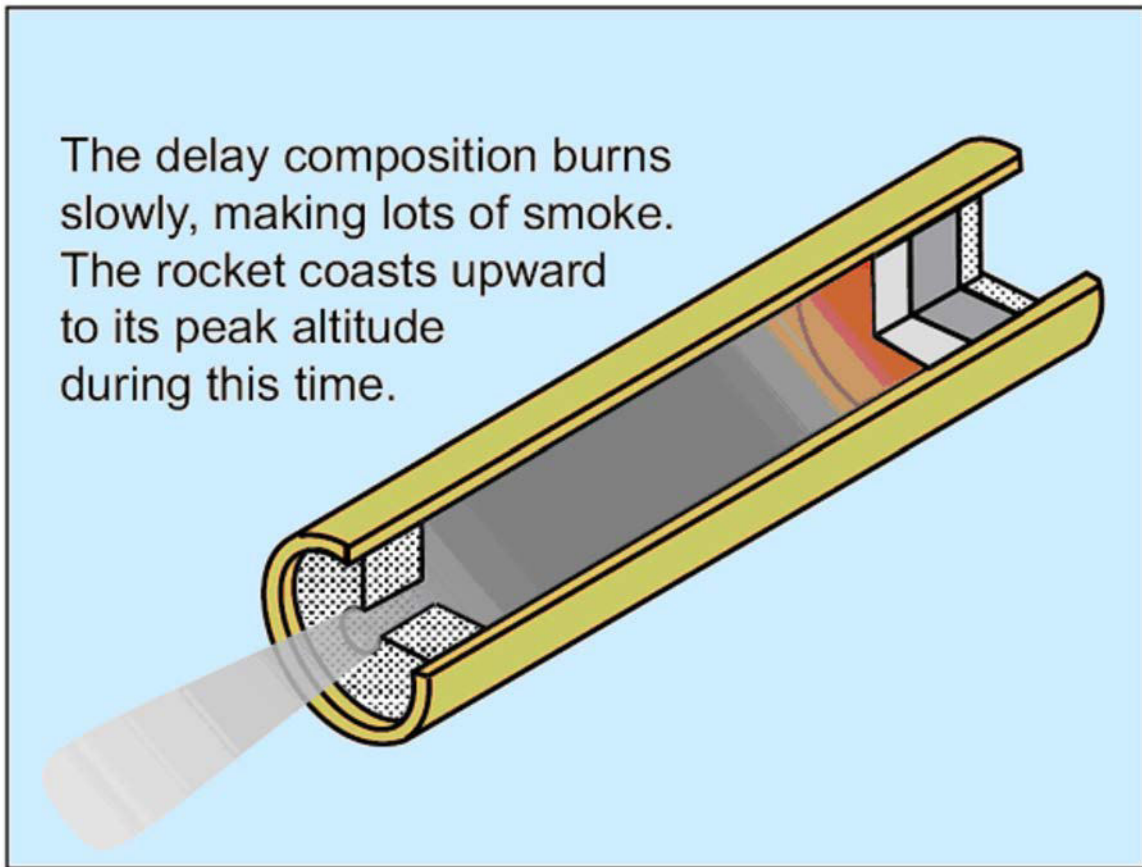

Figure A-9 Delay or Coast Phase

*Note.* From "Apogee Peak of Flight Newsletter", 2003, *How Black Powder Rocket Motors Work*. Retrieved November 16, 2007, from <http://www.apogeerockets.com/educator/downloads/newsletter114.pdf>

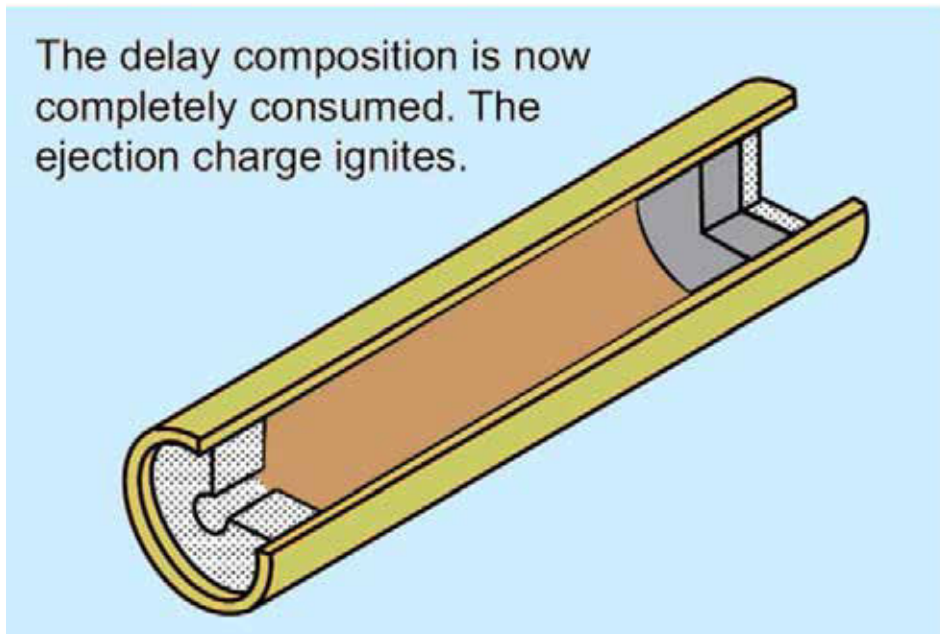

Figure A-10 Beginning of the Ejection Phase

Note. From "Apogee Peak of Flight Newsletter", 2003, *How Black Powder Rocket Motors Work*. Retrieved November 16, 2007, from <http://www.apogeerockets.com/educator/downloads/newsletter114.pdf>

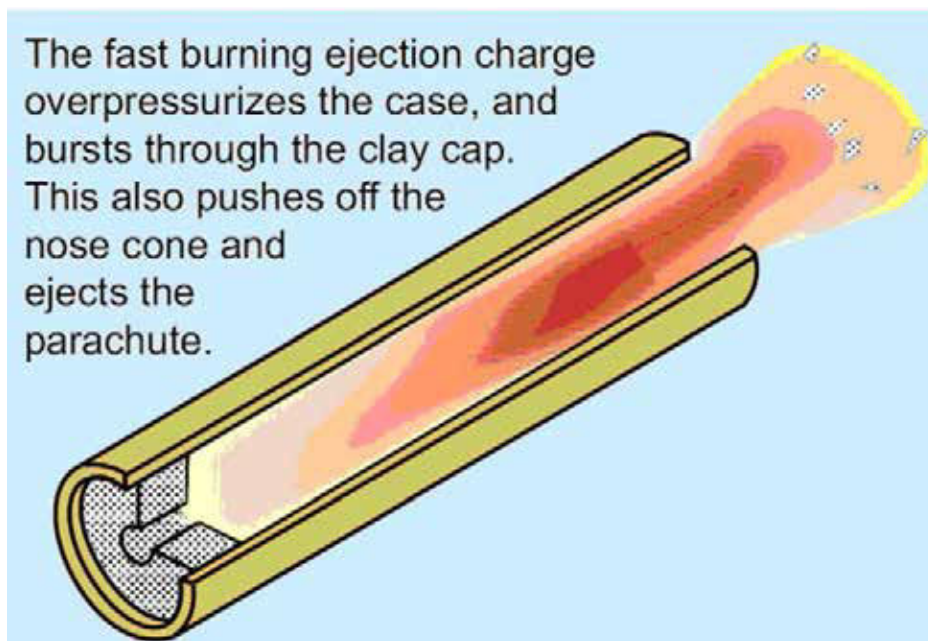

Figure A-11 Ejection Phase

Note. From "Apogee Peak of Flight Newsletter", 2003, *How Black Powder Rocket Motors Work*. Retrieved November 16, 2007, from <http://www.apogeerockets.com/educator/downloads/newsletter114.pdf>

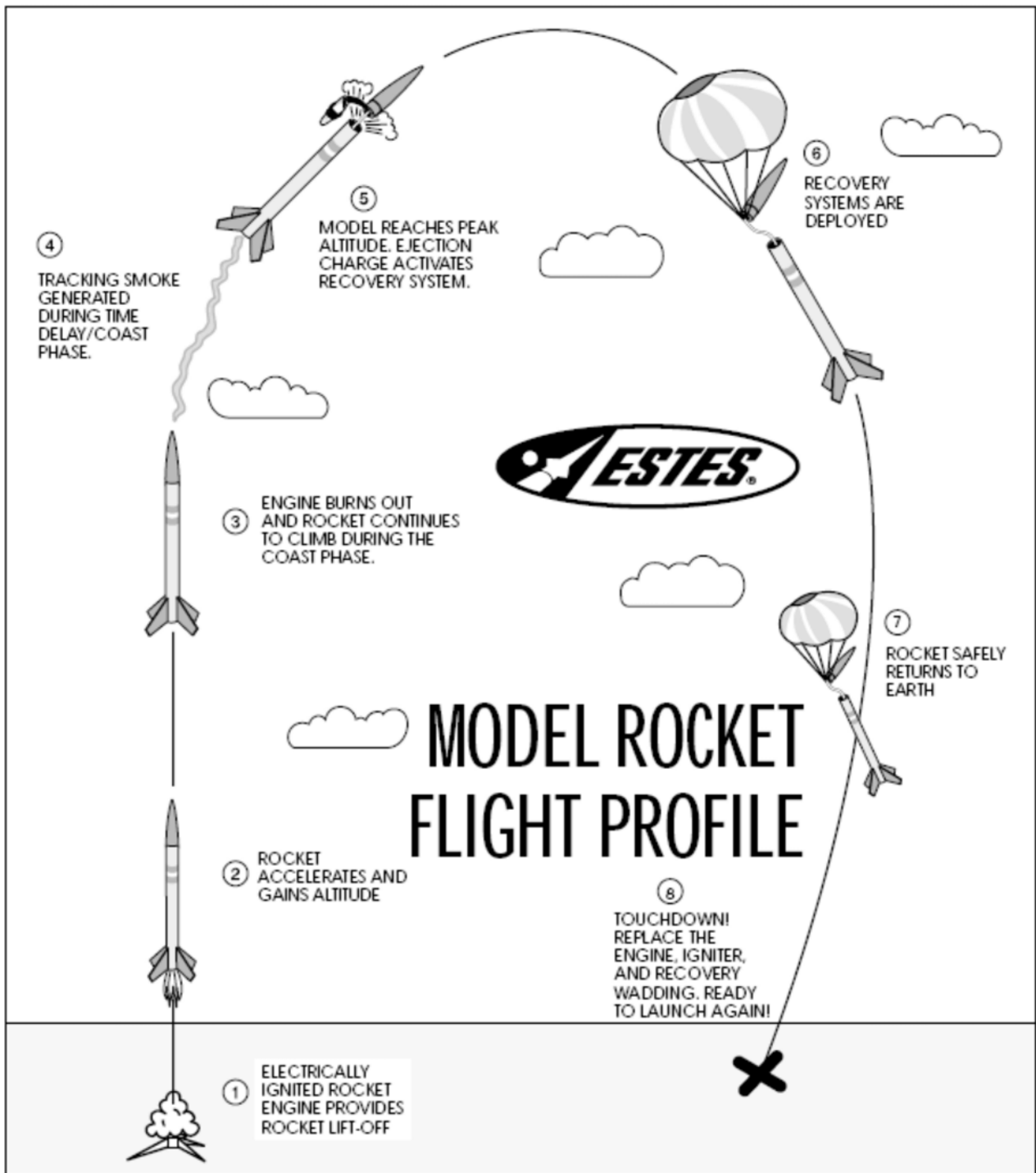

Figure A-12 Model Rocket Flight Profile

Note. From "Estes Rocketry", 1993, by T. Beach, 2003, *Model Rocketry Technical Manual*. Retrieved October 10, 2007, from <http://www.estesrockets.com/assets/downloads/rocketrytechniques.pdf>

THIS PAGE INTENTIONALLY LEFT BLANK

## CANADIAN ASSOCIATION OF ROCKETRY: CANADA MODEL ROCKET SAFETY CODE

1. **CONSTRUCTION:** I will always build my model rocket using only lightweight materials such as paper, wood, plastics and rubber without any metal airframe components. My model shall include aerodynamic surfaces or a mechanism to assure a safe, stable flight.
2. **ENGINES:** I will use only pre-loaded, commercially available model rocket engines approved safe by Energy, Mines and Resources Canada. I will never subject these engines to excessive shock, extremes of temperature, nor will I ever attempt their reloading or alteration. I shall always employ recommended manufacturer handling and ignition procedures.
3. **RECOVERY:** My model rocket will always utilize a recovery system to return it safely to the ground so that my model rocket may be reflown. I shall prepare the recovery system with due care to assure that it will properly deploy.
4. **WEIGHT LIMITS:** My model rocket will not weigh more than 1500 grams at liftoff and the model rocket engine(s) will contain no more than 125 grams of propellant.
5. **FIRING SYSTEM:** I will always use a remote, electrical system to ignite the model rocket engine(s). My firing system will include an ignition switch that will return to "OFF" when released, and a safety interlock key switch to prevent accidental ignition. I will never leave the safety interlock key in my firing system between launches.
6. **LAUNCH SYSTEM:** My model rocket will always be launched from a stable platform having a device to initially guide its motion. My launch system will have a jet deflector to prevent the engine exhaust from directly contacting the ground, or inflammable launcher components. To protect others and myself from eye injury, I will position the launch rod or rail so that the upper end is above eye level, or else I will place a large guard on the upper end between launches. I will never place my body or hand directly over my loaded model rocket mounted on the launch system.
7. **LAUNCH SITE:** I will never launch my model rocket near buildings, power lines or within 9.1 kilometres from the centre of an airport. The area immediately around the launch system will be cleared of any flammable materials. I will always obtain the permission of the launch site owner prior to using the launch site for my model rocket activities.
8. **LAUNCH CONDITIONS:** I will never launch my model rocket in high winds or under conditions of low visibility that may impair the observation of my model rocket in flight, or in a direction below 30 degrees from the vertical.
9. **LAUNCH SAFETY:** I will remain at least five metres away from any model rocket about to be launched. I will always announce to persons within the launch site that I am about to launch my model rocket, and I shall give a loud countdown of at least five seconds duration. I shall immediately remove the safety interlock key from my firing system after the launch of my model rocket.
10. **MISFIRE:** In the event of an ignition misfire, I shall not immediately approach my model rocket, but remove the safety interlock key and remain back for a safe period until assured that no ignition will occur.
11. **ANIMAL PAYLOADS:** I will never endanger live animals by launching them in my model rocket.
12. **TARGETS:** I will never launch my model rocket so that it will fall on or strike ground or air targets, nor will I include any explosive or incendiary payload.
13. **HAZARDOUS RECOVERY:** I will never attempt to recover my model rocket from a power line, high place or other dangerous location.

14. PRE-FLIGHT TESTS: Whenever possible, I will, always test the stability, operation and reliability of my model rocket designs prior to flight. I will launch unproven designs in complete isolation from other persons.
15. PERSONAL CONDUCT: I will always conduct myself in a responsible manner, conscious that the maintenance of safety for others and myself rests with my ability to design and construct sound, working models, and to enthusiastically abide by the Canada Model rocket Safety Code.

2. CANADIAN ASSOCIATION OF ROCKETRY: MODEL ROCKET STANDARDS
  - 2.1 A "model rocket" is defined as a heavier-than-air flying rocket having a substantially non-metallic airframe, employing the reaction force of a model rocket engine as its sole source of lift and incorporating an automatically initiated system that will assure a safe descent and model reusability.
  - 2.2 The model rocket shall be constructed of wood, paper, plastic or similar lightweight materials. No substantial metal components shall be incorporated in the model rocket airframe.
  - 2.3 The model rocket shall embody aerodynamic surfaces and / or a guidance system, which will develop the necessary stabilizing and restoring forces to produce and maintain a safe, predictable and substantially vertical flight path. Model rockets, which employ an internally or externally controlled guidance system, shall incorporate sufficient inherent stability to fail safe any malfunction or disabling of the guidance system.
  - 2.4 The model rocket shall incorporate a reliable and effective means, of retarding its descent so that no hazard shall be presented to 'persons or property on the ground, and to prevent model damage upon touchdown so as to enable reflight. All engine casings and / or portions of the model jettisoned from the model rocket during flight shall descend with a fully deployed streamer or parachute, or by aerodynamic surfaces, which will induce rapid tumbling or a shallow glide. Minimum loading requirements shall be five (5) square centimetres per gram for parachutes, and ten (10) square centimetres per gram for streamers.
  - 2.5 A model rocket shall utilize no more than three powered stages. A "powered stage" shall be defined as a unit of the whole model rocket airframe which contains one or more model rocket engines, and which is designed to and / or actually separates as a unit in flight after the burnout of its contained engine(s). The number of powered stages used shall be assessed from the staged model configuration at the instant of its first motion on the launcher.
  - 2.6 A model rocket incorporating a self-energized firing system shall contain a safety interlock switch that will disable the firing circuit when "OFF". Activation of the firing system shall occur only immediately prior to launch. The self-energized firing system shall include a safe and reliable provision to test circuit continuity.
  - 2.7 All combustible materials subject to high temperature developed by the function of any model rocket engine, burning-wick dethermalizer or other auxiliary devices operating at higher than 200 degrees Celsius shall be flame proofed or similarly protected to prevent their ignition. Any on-board device, which initiates ignition and / or employs combustion, shall be self-extinguishing upon termination of actual or intended function.
  - 2.8 A model rocket shall never contain an explosive or pyrotechnic payload, nor shall it be used to launch a living animal.
  - 2.9 The maximum or gross mass of a model rocket at launch shall not exceed 1500 grams.
  - 2.10 The model rocket shall contain no more than 125 grams of propellant grain.

THIS PAGE INTENTIONALLY LEFT BLANK





**ROYAL CANADIAN AIR CADETS  
PROFICIENCY LEVEL FOUR  
INSTRUCTIONAL GUIDE**



**SECTION 4**

**EO C440.02 – LAUNCH A SMALL MODEL ROCKET**

---

Total Time:	90 min
-------------	--------

---

**PREPARATION**

---

**PRE-LESSON INSTRUCTIONS**

Resources needed for the delivery of this lesson are listed in the lesson specification located in A-CR-CCP-804/PG-001, *Proficiency Level Four Qualification Standard and Plan*, Chapter 4. Specific uses for said resources are identified throughout the instructional guide within the TP for which they are required.

Review the lesson content and become familiar with the material prior to delivering the lesson.

Locate a proposed launch site IAW the Launch Site Set-Up located at Attachment A.

Ensure that permission to launch a small model rocket has been received from airport authorities.

Ensure that written permission to use the launch location has been received from the property owner.

Perform a risk assessment of the launch location.

Practice rocket engine and igniter installation.

Assemble the rocket launch controllers and launch towers.

**PRE-LESSON ASSIGNMENT**

Nil.

**APPROACH**

A practical activity was chosen for this lesson as it is an interactive way to introduce the cadets to constructing and launching model rockets in a safe, controlled environment.

---

**INTRODUCTION**

---

**REVIEW**

Nil.

**OBJECTIVES**

By the end of this lesson, the cadet shall have launched a small model rocket.

**IMPORTANCE**

It is important for cadets to experience the thrill of launching a model rocket, as it will stimulate an interest in aerospace, model rocketry and the Air Cadet Program. Launching a small model rocket that they built themselves will also develop in cadets a sense of pride and accomplishment.

**Teaching Point 1****Demonstrate and have the cadets assemble a model rocket.**

Time: 25 min

Method: Practical Activity

**ACTIVITY****OBJECTIVE**

The objective of this activity is to have the cadets assemble a model rocket.

**RESOURCES**

- No. 11 hobby knives,
- Cement for plastic models,
- Scissors,
- Pencil, and
- Model rocket kit that utilizes an A-series engine.

**ACTIVITY LAYOUT**

Nil.

**ACTIVITY INSTRUCTIONS**

1. Familiarize the cadets with the parts of the rocket.
2. Distribute one model rocket kit to each cadet.
3. Demonstrate and have the cadets, in pairs, complete the steps in building a model rocket.

**SAFETY**

- Caution is required when using sharp tools.
- Provide adequate ventilation when using solvent-based glues.

**CONFIRMATION OF TEACHING POINT 1**

The cadets' participation in the activity will be the confirmation of this TP.

**Teaching Point 2****Have the cadets assist in the set-up of the rocket launch site.**

Time: 20 min

Method: Practical Activity



Have the cadets assist in the set-up of the rocket launch site IAW Attachment A.

---

## CONFIRMATION OF TEACHING POINT 2

The cadets' participation in the activity will serve as the confirmation of this TP.

---

### Teaching Point 3

**Have the cadet launch a small model rocket.**

Time: 35 min

Method: Practical Activity

---

## ACTIVITY

### OBJECTIVE

The objective of this activity is to have the cadets launch the small model rockets assembled in TP 1.

### RESOURCES

- Preassembled model rockets from TP 1,
- Rocket launch site setup drawing located at Attachment A,
- Model rocket launching procedure located at Attachment B,
- Model rocket launch tower,
- Model rocket launch controller,
- 80 m of safety tape,
- 18 modular tent pegs or a suitable substitute,
- Safety glasses,
- Voltmeter,
- Pliers,
- Screwdriver, and
- Electrical tape.

### ACTIVITY LAYOUT

The rocket launch site will be set up IAW Attachment A.

### ACTIVITY INSTRUCTIONS

1. Follow the model rocket launching procedure located at Attachment B.
2. Have the cadets install the igniters in the rocket engines.
3. Have the cadets install the rocket engines in the rockets.
4. Have the cadets place the rockets on the launch pads.
5. Have the cadets press the launch buttons and launch their rockets.

6. Have the cadets track the rockets through its flight.
7. After the rockets have landed, have the cadets recover them.

**SAFETY**

- Ensure control of the entire rocket site at all times.
  - Only the instructor and the cadets launching the rockets will be in the launch control area.
  - Spectators will remain at least 20 m from the launch tower.
  - Engines should be kept in a steel box and only distributed when the rockets are ready to be launched.
  - Horseplay will not be tolerated at any time during the launching of model rockets.
  - Recovery should be done quickly as delay may prevent the launching of all the rockets.
- 

**CONFIRMATION OF TEACHING POINT 3**

The cadets' participation in the activity will serve as the confirmation of this TP.

---

**END OF LESSON CONFIRMATION**

The cadets' participation in the small model rocket launch will serve as the confirmation of this lesson.

---

**CONCLUSION**

---

**HOMEWORK / READING / PRACTICE**

Nil.

**METHOD OF EVALUATION**

Nil.

**CLOSING STATEMENT**

A model rocket is subject to the same forces and laws of nature as a space-program launch vehicle. Experience with model rockets will give the hobbyist useful space program insights.

**INSTRUCTOR NOTES / REMARKS**

EO C440.01 (Describe Model Rocketry) must also be selected and delivered prior to this lesson.

Cadets who are qualified Advanced Aerospace may assist with this instruction.

---

## REFERENCES

---

C3-162 Beach, T. (1993). *Model rocketry technical manual*. Retrieved October 10, 2007, from <http://www.estesrockets.com/assets/downloads/roeketrytechniques.pdf>

C3-163 Cannon, R. L. (1999). *A learning guide for model rocket launch systems*. Retrieved October 10, 2007, from <http://www.estesrockets.com/assets/downloads/launchsystemguide.pdf>

C3-259 ISBN 978-0-471-47242-1 Stine, G. H. (2004). *Handbook of model rocketry*. Toronto, ON: John Wiley & Sons.

## LAUNCH SITE SET-UP

1. A safety briefing will be held before the launch site is set up, covering the following points:
  - a. The Launch Control Officer (LCO) is the only person permitted to activate the launch control panel.
  - b. All launch systems will be placed in "safe" mode between each flight.
  - c. When a rocket is descending out of control, launch site personnel will point at the rocket and repeat the phrase "heads up" until the rocket has landed.
  - d. No horseplay will be tolerated.
  - e. A safe rendezvous point will be clearly indicated and in the event of an emergency, launch site staff will move all cadets and staff to this point.
  - f. The area required for launching model rockets should be at least 100 m square. It should not have any tall buildings, trees, power lines or other tall objects close by. The cadets and spectators should be located in an area at least 20 m from the launch towers. Bleachers at a baseball field or soccer field are suitable.
  - g. If the site is within 9 km (5.6 miles) from an aerodrome, the aerodrome must be advised of the date and time the rockets will be launched. The rocket can reach a height of 200–400 feet at apogee and can be flown safely from the suggested field size.
2. Wind will play an important factor in the rocket's recovery. The descending rocket will drift with the wind and if descending too slowly will land far from the launch site. Rockets should not be launched in winds stronger than 35 km / h (28 miles per hour).



If the first rockets launched descend too slowly resulting in the rockets landing far from the launch site, a hole can be cut in the centre of the parachute to speed up the rockets descent.

3. Layout the rocket launch site as per Figure A-1. Wind direction should be accounted for by placing the towers closer to the windward side of the field.
4. Using modular tent pegs or a suitable substitute as posts, cordon off a 10 m by 10 m security tape border around the launch towers and a 10 m by 10 m security tape border around the launch control site leaving a 1 m opening for access.
5. Assemble the launch towers as per directions included with the towers. Place the launch towers in a line perpendicular to the wind. The launch rods should point slightly into the wind.
6. Place the launch control panels on the launch control tables and run the wire from each of the launch control boxes to the launch towers ensuring the wires are not tangled and in good working order.
7. All rockets will be brought to the rocket holding area before the launch begins.
8. Make sure all the connections are clean and tight.

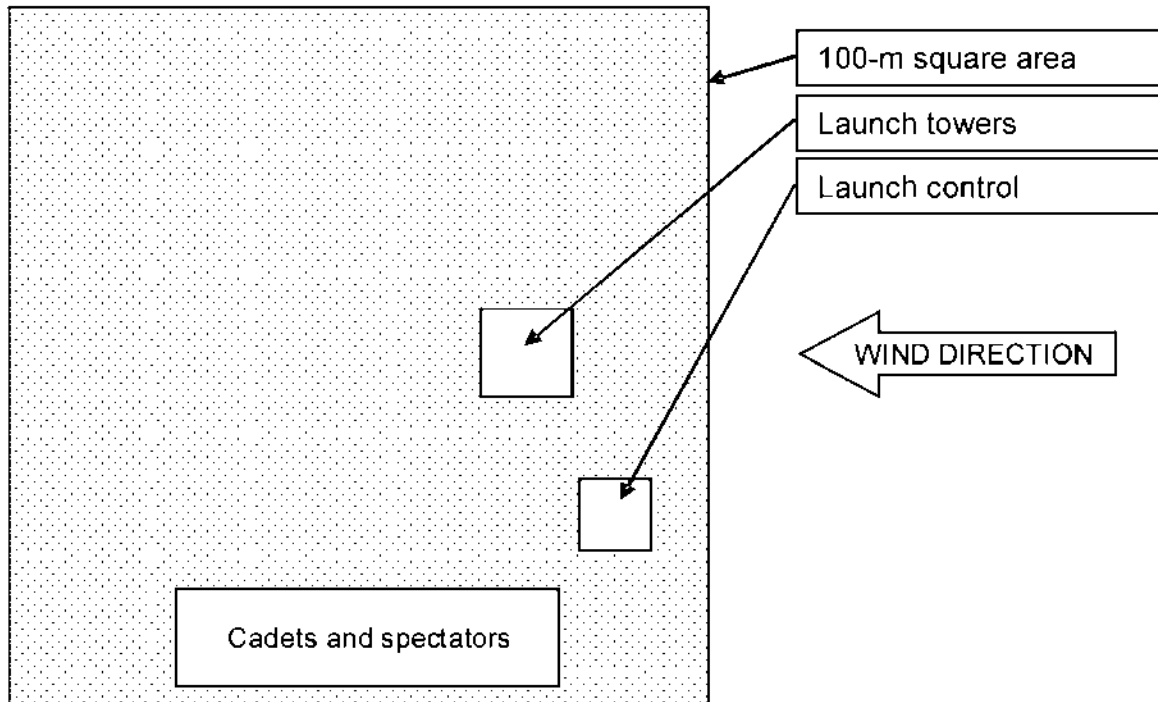

Figure A-1 Layout for a Rocket Launch Site

Note. Created by Director Cadets 3, 2008, Ottawa, ON: Department of National Defence.

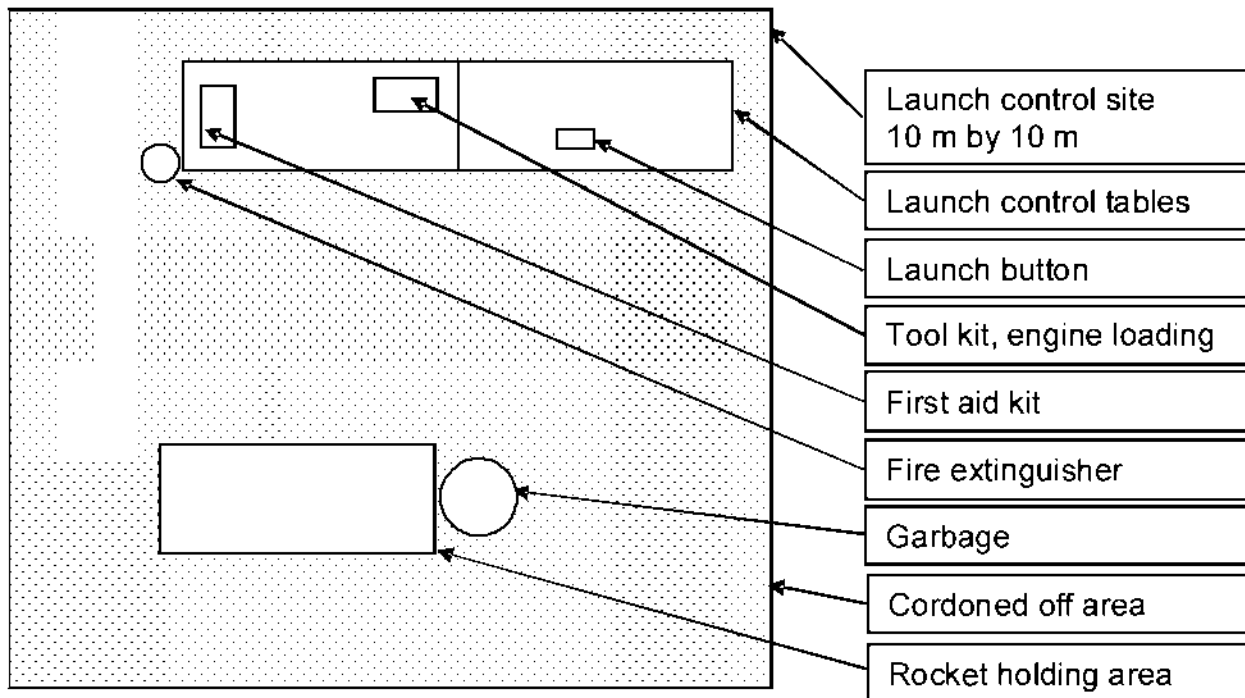

Figure A-2 Layout for a Launch Control

Note. Created by Director Cadets 3, 2008, Ottawa, ON: Department of National Defence.



## MODEL ROCKET LAUNCH PROCEDURE

1. Place the launch control switches in the safe position.
2. Collect the rockets from the cadets and prepare them for launch by following the directions included with the model rocket, launch control and launch towers.



The igniters should be handled with care, as damaged igniters are the cause of most misfires.

3. Following the launch tower directions, install one rocket on each launch tower.
4. Verify the launch control switches are in the safe position.
5. Connect the two alligator clips from each launch controller to the igniter leads on each of the rockets.
6. Make sure everyone stands back from the launch towers and have the cadets start a countdown from ten, backwards to zero.
7. Place the safe switches in the launch position.
8. Have the cadets press the launch buttons and launch their rockets.



If the rocket does not lift off the pad, wait at least one minute before approaching the pad. See Attachment C for troubleshooting the launch system.

9. Have the cadets track the rockets through their flights.
10. After the rockets have landed, allow the cadets to recover them.



After each flight, the alligator clips at the launch towers should be cleaned with 280-grit sandpaper and replaced when they can no longer be cleaned effectively.

THIS PAGE INTENTIONALLY LEFT BLANK

### **IF THE ROCKET ENGINE DOES NOT IGNITE**

1. Place the launch control button in the safe mode.
2. Wait one minute before approaching the launch tower. This will ensure the engine is no longer able to ignite.
3. Undo the alligator clips from the igniter and remove the rocket from the launch tower.
4. At the launch tower, test the power with a voltmeter to ensure there is voltage present by setting the voltmeter to "V" and placing the tower's alligator clips on the leads of the voltmeter, red to red and black to black.
5. With all the wires connected and the launch button pressed, the launch control lights should be on and the voltmeter should read approximately the voltage of the combined batteries (eg, three batteries at 1.5 volts each equals 4.5 volts).
6. If the lights on the launch control do not light or the voltmeter registers low voltage or no voltage at all, the batteries are weak or dead, one of the wires is broken, or there is a loose connection at the launch control or the launch pad.
7. To trace the problem, start at the launch control and ensure there are fresh batteries. If the batteries are fresh and correctly installed, proceed to the launch tower and verify if there is voltage at the launch tower. Repair any breaks in the wire or loose connections.
8. Verify that the igniter leads are not touching each other and that the igniter tip is not broken. If the igniter appears to be unserviceable, install a new igniter and restart the launch process.

THIS PAGE INTENTIONALLY LEFT BLANK



**ROYAL CANADIAN AIR CADETS**  
**PROFICIENCY LEVEL FOUR**  
**INSTRUCTIONAL GUIDE**



**SECTION 5**

**EO C440.03 – DISCUSS CHARACTERISTICS OF THE PLANETS IN THE SOLAR SYSTEM**

---

Total Time:	60 min
-------------	--------

---

**PREPARATION**

---

**PRE-LESSON INSTRUCTIONS**

Resources needed for the delivery of this lesson are listed in the lesson specification located in A-CR-CCP-804/PG-001, *Proficiency Level Four Qualification Standard and Plan*, Chapter 4. Specific uses for said resources are identified throughout the instructional guide within the TP for which they are required.

Review the lesson content and become familiar with the material prior to delivering the lesson.

Photocopy the Planets Specifications Sheet located at Attachment A for each cadet.

Create slides of Attachment B to be used in the end of lesson confirmation.

**PRE-LESSON ASSIGNMENT**

Nil.

**APPROACH**

An interactive lecture was chosen for this lesson to introduce the cadets to the characteristics of the planets in the solar system and to generate interest in the subject.

---

**INTRODUCTION**

---

**REVIEW**

Nil.

**OBJECTIVES**

By the end of this lesson the cadet shall have discussed the characteristics of the planets in the solar system.

**IMPORTANCE**

It is important for cadets to know the characteristics of the planets in our solar system as space exploration continues to develop. The exploration of the solar system is long term and will span many generations. Cadets who are familiar with the solar system may be able to contribute to this exploration.



Distribute to each cadet a copy of the Planet Specifications Sheet located at Attachment A to be completed as the information is presented during the lesson.

### Teaching Point 1

**Discuss the planet Mercury.**

Time: 5 min

Method: Interactive Lecture

## MERCURY

The planet Mercury, named for the Roman messenger god, is the closest planet to the sun. It is the smallest planet and a cratered wasteland. Since it is so close to the sun it means the planet is completely at the mercy of solar radiation, solar flares, and other solar weather phenomena. The planet is also battered by the many asteroids that float through space. The sun's gravitational pull means that these free floating bodies of rock accelerate towards the sun. Depending on Mercury's position in orbit, these asteroids may impact its surface. There are craters on Mercury that are 600 km wide. Our knowledge of this planet is still incomplete. Only one man-made satellite has ever passed by Mercury, and it was able to collect information about only a small portion of the planet's surface.

### Mean Distance From the Sun

Mercury is the closest planet to the sun. The range varies from 46 million to 69.8 million km. The mean distance is 57.9 million km.

### Size

Mercury's diameter is a mere 4 879 km. The planet's diameter is only 0.383 times that of Earth.

### Mass

Mercury is the smallest planet in our solar system. Its mass is 0.0553 times the mass of Earth.

### Rotation

Despite the quick pace that the planet travels around the sun, Mercury does not rotate around its own axis very quickly. It takes 58.65 days for the planet to rotate around its axis, or two-thirds of a Mercurian year.

### Inclination

The axis of Mercury sits at an angle of 0.01 degrees relative to the sun's axis.

### Orbit Characteristics

Mercury has what is known as an eccentric orbit. This means that the distance the planet is from the sun varies throughout its revolution around the sun. The actual shape that the planet would travel around the sun would be an ellipse. This can be seen in the extreme range in the planet's distance from the sun. Mercury travels around the sun once every 88 days. This means that the Mercurian year is 88 days long. Mercury's synodic period is 115.9 days.



**Synodic period.** The time it takes for a planet to return to a specific spot in the night sky as observed from Earth.

Mercury has an average orbital velocity of 47.9 km / s. This means that the planet travels in its orbit around the sun at an average speed of 47.9 km / s or 172 440 km / h.

### **CONFIRMATION OF TEACHING POINT 1**

The cadets' completion of Mercury's specification box on the Planet Specification Sheet will serve as the confirmation of this TP.

### **Teaching Point 2**

Time: 5 min

**Discuss the planet Venus.**

Method: Interactive Lecture

## **VENUS**

Travelling from the sun past Mercury, the next planet is Venus. Named for the Roman goddess of love and beauty, Venus is constantly cloaked in cloud. This permanent cover means that scientists know very little about the surface of the planet. Observed from Earth, Venus is the brightest planet in the night sky. The Space Age has greatly enhanced our understanding of this planet. Prior to the 1960s, it was thought that Venus was an oceanic planet equivalent in vegetation to Earth during pre-historic periods. Since the 1960s, several satellites have been sent to Venus or on a path near Venus. These satellites have included Mariner 2 and 10, and the Russian Venera 7, 9, and 13 landings.

### **Mean Distance From the Sun**

Venus is the second closest planet to the sun at a mean distance of 108.2 million km. The distance can range from 107.5 million to 108.9 million km.

### **Size**

Venus is very similar in size to Earth. Many scientists refer to Venus and Earth as near-twins. The diameter of the planet at the equator is 12 104 km, approximately 0.949 times that of Earth.

### **Mass**

The mass of Venus is approximately 0.815 times the mass of Earth.

### **Rotation**

Venus is unique in that it is the only planet in our solar system which rotates east to west, or clockwise. All other planets, including Earth, rotate west to east or counter-clockwise. It takes just over 243 days for Venus to rotate around its axis. It should be noted that this is longer than the Venusian year.

### **Inclination**

The axis of Venus sits at an angle of 177.4 degrees. This means that the planets north pole is actually at the bottom of the planet.

### **Orbit Characteristics**

Venus' orbit around the sun is almost perfectly circular which explains the small range of distance from the sun. It takes 224.7 days for Venus to complete one revolution around the sun. This means that one year on Venus is 224.7 days long. Venus' synodic period is 583.92 days, meaning that the planet will return to the same point in the Earth's sky almost every two years. Venus has an orbital velocity of 35.02 km / s or 126 072 km / h.

---

## CONFIRMATION OF TEACHING POINT 2

The cadets' completion of Venus' specification box on the Planet Specification Sheet will serve as the confirmation of this TP.

---

### Teaching Point 3

**Discuss the planet Earth.**

Time: 10 min

Method: Interactive Lecture

---

## EARTH

The Earth is the third planet from the sun and is the only planet known to support life. The Earth's atmosphere is composed mainly of nitrogen and oxygen. The temperatures are moderate, due to the ozone layer found in our atmosphere. There is water on Earth, which in current scientific belief is an absolute requirement for life.

Earth has one naturally occurring satellite, Luna. Usually, Luna is simply referred to as the moon. The moon has a profound effect on Earth. Not only is it a constant feature in the night sky, but being the brightest object means that it can provide light on a clear night. Being so close to the Earth (384 000 km) and with a diameter of 3 475 km, the moon also has a gravitational effect on our planet. This effect is most apparent in the tidal patterns of our oceans.

### Distance From the Sun

The Earth's average distance from the sun is 149.6 million km. Due to the orbit this can range from 147.1 million to 152.1 million km.

### Size

Since humans have studied the Earth in depth, we tend to base all of our concepts of planet size relative to the Earth. Earth is therefore the standard by which we measure the size of other planets. Earth's diameter is 12 756 km at the equator.

### Mass

Earth's mass is  $5.97 \times 10^{21}$  tonnes. Earth's ratio values for both size and mass are one, since we use the Earth as the standard for measurement.

### Rotation

The Earth rotates west to east around its axis. It takes 23h 56m 04s for the Earth to complete one rotation. This means that the standard Earth day is approximately 24 hours in length.

### Inclination

Earth's axis is tilted at an angle of 23.5 degrees.

### Orbit Characteristics

The Earth's orbit is very circular as seen by the small range in distance from the sun. It takes 365.2 days for the Earth to revolve once around the sun. As such, our standard year is 365 days in length with a leap year every four years to take into account the 0.2 days. The Earth has an orbital velocity of 29.8 km / s or 107 280 km / h.



---

**CONFIRMATION OF TEACHING POINT 3**

The cadets' completion of Earth's specification box on the Planet Specification Sheet will serve as the confirmation of this TP.

---

**Teaching Point 4****Discuss the planet Mars.**

Time: 5 min

Method: Interactive Lecture

---

**MARS**

Mars is the fourth planet from the sun. Named after the Roman god of war due to its red colour, there are many legends that claim this planet was bright in the sky on the eve of many great victories. Mars has taken a central place in many of today's space programs. At its closest, Mars is 59 million km away from Earth, making it the second-closest planet after Venus. During the space race of the 1960s, the goal was to be the first to set foot on the moon. Now, there is a collaborative effort by many international space agencies to send a manned mission to Mars. The planet itself is currently deemed uninhabitable without the use of artificial environment resources. There have been many probes sent to Mars in recent years to assess the natural environment and evaluate what equipment would be needed in order to sustain human life on the planet.

**Mean Distance From the Sun**

Mars is nearly twice the Earth's distance from the sun. The mean distance the planet is from the sun is 227.9 million km. This ranges from 206.6 million to 249.2 million km depending on its position in its orbit around the sun.

**Size**

The diameter of Mars at the equator is 6 792 km, which is 0.532 times that of Earth.

**Mass**

The mass of Mars is 0.107 times that of Earth.

**Rotation**

Like Earth, Mars' rotation is west to east and takes 24h 39m 35s. In other words, a standard Earth day is very close in duration to a Martian day.

**Inclination**

The axis of Mars is also very similar to Earth's. The axis of Mars is tilted at an angle of 25.2 degrees.

**Orbit Characteristics**

The orbit of Mars is eccentric, as shown by the large range in distance from the sun. Mars will revolve around the sun once every 687 days (a little less than two years). Mars has an orbital velocity of 24.1 km / s or 86 760 km / h.

---

**CONFIRMATION OF TEACHING POINT 4**

The cadets' completion of Mars' specification box on the Planet Specification Sheet will serve as the confirmation of this TP.

---

**Teaching Point 5****Discuss the planet Jupiter.**

Time: 10 min

Method: Interactive Lecture

---

**JUPITER**

After passing through the ring of the asteroid belt, the next planet past Mars is Jupiter, the innermost gas giant planet. Named after the leader of the Roman gods (Zeus to the Greeks), Jupiter is the largest planet in our solar system. Despite its distance from the Earth, the only planets that can outshine it in the night sky are Earth's neighbours, Venus and Mars.

Jupiter has 63 known natural satellites. Of these, 47 are less than 10 km in diameter, and only 4 are large enough to be considered moons. These are identified as Galilean moons and include:

- Io is in orbit 421 600 km from the centre of Jupiter and takes 1.7 days to orbit the planet. The dimensions of Io are not exactly spherical, measuring 3 660 km by 3 637 km by 3 631 km.
- Europa is in orbit 670 900 km from the centre of Jupiter. It takes 3.5 days for the moon to orbit the planet once. Europa is 3 130 km in diameter.
- Ganymede is in orbit 1 070 000 km from the centre of Jupiter and it takes 7.2 days to complete one full orbit of the planet. Ganymede is 5 268 km in diameter.
- Callisto is in orbit 1 880 000 km from the centre of Jupiter and orbits once every 16.7 days. Callisto is 4 806 km in diameter.

**Mean Distance From the Sun**

Though Jupiter is the fifth planet in our solar system, the separation provided by the asteroid belt means that Jupiter is a great distance from the sun. The mean distance of Jupiter from the sun is 778.4 million km. Due to its orbit this distance can range from 740.5 million to 816.6 million km.

**Size**

The diameter of Jupiter at its equator is 142 984 km, 11.21 times that of Earth. Due to the rotation of Jupiter, there is a significant difference between the diameter at the equator and the diameter at the poles. The polar diameter is 133 700 km, almost 10 000 km less than the equatorial diameter. By comparison, the difference in diameter between the Earth's equator and poles is a mere 42 km.

**Mass**

Jupiter's mass is 317.8 times the mass of Earth.

**Rotation**

Jupiter rotates at an immense speed which causes the equator to bulge out. This is the reason for the large difference between the equatorial and polar diameters. One day on Jupiter is only 9h 55m 30s.

**Inclination**

Jupiter's axis is only 3.1 degrees from the perpendicular, meaning that Jupiter is almost straight up and down.

**Orbit Characteristics**

Jupiter has a slightly eccentric orbit. Due to its distance from the sun, it takes the planet 4 331 days (11.86 years) to revolve around the sun. The orbital velocity of Jupiter is 13.1 km / s or 47 160 km / h. Jupiter's synodic period is 398.9 days.

---

**CONFIRMATION OF TEACHING POINT 5**

The cadets' completion of Jupiter's specification box on the Planet Specification Sheet will serve as the confirmation of this TP.

---

**Teaching Point 6****Discuss the planet Saturn.**

Time: 5 min

Method: Interactive Lecture

---

**SATURN**

Saturn is a very distinct planet in our solar system. It is the second of the gas giants from the sun, the sixth planet in the system. Named after the Roman god of time because of the length of time it takes for the planet to cross the night sky, Saturn is said to be the most beautiful object in the sky when viewed through a telescope.

**Mean Distance From the Sun**

Saturn is more remote than Jupiter. Orbiting at a mean distance of 1 433.5 million km, Saturn is almost twice as far from the sun as Jupiter.

**Size**

Saturn's equatorial diameter is 120 536 km, which is more than nine times that of the Earth. Saturn is the second largest planet in the solar system.

**Mass**

Saturn's mass is 95.2 times the mass of Earth.

**Rotation**

Saturn rotates on its axis once every 10h 13m 59s. Like Jupiter, the speed at which this occurs causes a slight bulging at the equator, causing the large distortion between the equatorial diameter and the polar diameter.

**Inclination**

The axis of Saturn tilts at an angle of 26.7 degrees.

**Orbit Characteristics**

Saturn has a slightly eccentric orbital path. It travels around the sun in 10 747 days or 29.43 years. Saturn's synodic period is 378.1 days. The orbital velocity of Saturn is 9.7 km / s or 34 920 km / h.

---

**CONFIRMATION OF TEACHING POINT 6**

The cadets' completion of Saturn's specification box on the Planet Specification Sheet will serve as the confirmation of this TP.

---

**Teaching Point 7****Discuss the planet Uranus.**

Time: 5 min

Method: Interactive Lecture

---

**URANUS**

Uranus is a very distinct planet which shares some of the characteristics of Saturn. Most prominent of these are the rings which orbit the planet, but even here there is uniqueness. Uranus is barely visible to the naked eye and the study of Uranus actually led to the discovery of the next planet in the solar system. The planet is named after the mythological father of Saturn.

**Mean Distance From the Sun**

Uranus is the second-furthest planet from the sun. The mean distance is 2 872.5 million km with a maximum of 3 003.6 million km and a minimum of 2 741.3 million km. Compared to Saturn, Uranus is twice as far from the sun and four times as far as Jupiter.

**Size**

Uranus is just over one third the size of Jupiter, but is still the third largest planet in the solar system. It has an equatorial diameter of 51 118 km, which is 4.01 times that of Earth.

**Mass**

Uranus' mass is 14.5 times that of Earth.

**Rotation**

Uranus rotates around its axis once every 17h 14m.

**Inclination**

The axis of Uranus tilts at an angle of 97.8 degrees. This means that it is technically on its side and the rings of Uranus look like they are vertical compared to Saturn's rings. Also, the satellites orbit Uranus on a vertical plane instead of a horizontal plane like the other planets.

**Orbit Characteristics**

Uranus has an irregular orbit. There is a point in the orbit where Uranus, as viewed from Earth, performs two 180-degree turns. This would look like a giant Z in the orbital path. It takes Uranus 83.76 years to orbit the sun once. Its mean orbit velocity is 24 607 km / h. The synodic period of Uranus is 369.7 days.

---

**CONFIRMATION OF TEACHING POINT 7**

The cadets' completion of Uranus' specification box on the Planet Specification Sheet will serve as the confirmation of this TP.

---

**Teaching Point 8****Discuss the planet Neptune.**

Time: 5 min

Method: Interactive Lecture

---

**NEPTUNE**

Named after the Roman god of the sea, Neptune was found as a result of scientific study of Uranus. Almost all of our knowledge of Neptune comes from one spacecraft, Voyager 2, which flew past the planet in 1989. The

atmosphere is made up predominantly of hydrogen, helium and methane. The planet is a very windy place, with equatorial winds in excess of 450 m / s or 1 620 km / h.

### **Mean Distance From the Sun**

Neptune is approximately half again as far as Uranus from the sun. Orbiting at a mean distance of 4 495.1 million km, it is 20 times as far as Mars. Neptune is the last planet in the solar system, keeping in mind that Pluto has been down-graded to a dwarf-planet.

### **Size**

Neptune is nearly identical in diameter to Uranus at 49 528 km, 3.88 times the diameter of the Earth.

### **Mass**

Neptune's mass is more than 18 percent greater than Uranus' and 17.1 times the mass of the Earth.

### **Rotation**

It takes Neptune 16h 7m to rotate once around its axis. This is the third fastest rotation of all of the planets.

### **Inclination**

The tilt of Neptune's axis is 28.3 degrees, slightly more than Earth's.

### **Orbit Characteristics**

Neptune's orbit is almost perfectly circular. It takes Neptune 163.7 years to orbit the sun, almost twice as long as Uranus. Its mean orbit velocity is 19 720 km / h. Neptune's synodic period is 367.5 days.

## **CONFIRMATION OF TEACHING POINT 8**

The cadets' completion of Neptune's specification box on the Planet Specification Sheet will serve as the confirmation of this TP.

## **END OF LESSON CONFIRMATION**

Show the cadets the slides of Attachment B and have them correct their own notes on the *Planet Specifications Sheet* located at Attachment A, which they completed during the lesson.

## **CONCLUSION**

### **HOMEWORK / READING / PRACTICE**

Nil.

### **METHOD OF EVALUATION**

Nil.

### **CLOSING STATEMENT**

The planets are more than just individual bodies floating in space. They are part of a large system and in some cases they are the centre of their own sub-system. Understanding the scale of this system is very important to understanding space exploration. With the mission to Mars moving in to the forefront of space news, we need to realize that this is not a small project, but one that could take years because of the distance and equipment

required. In addition, understanding the scale of the solar system and the scale location of the nearest star gives us a taste of the vastness of the universe and the importance of astronomy in our lives.

### **INSTRUCTOR NOTES / REMARKS**

Planetary data is provided in detail at <http://solarsystem.nasa.gov/planets/index.cfm>

Cadets who are qualified Advanced Aerospace may assist with this instruction.

---

### **REFERENCES**

---

C3-170 Ottewell, G. The National Optical Observatory. (1998). *Thousand-yard model: Or Earth as a peppercorn*. Retrieved October 16, 2007, from <http://noao.edu/education/peppercorn/pcmain.html>

C3-288 Williams, D. NASA. (2008). *Planetary fact sheet – metric*. Retrieved October 14, 2008, from <http://nssdc.gsfc.nasa.gov/planetary/factsheet/index.html>

C3-289 Williams, D. NASA. (2008). *Planetary fact sheet – ratio to earth values*. Retrieved October 14, 2008, from [http://nssdc.gsfc.nasa.gov/planetary/factsheet/planet\\_table\\_ratio.html](http://nssdc.gsfc.nasa.gov/planetary/factsheet/planet_table_ratio.html)

## PLANET SPECIFICATIONS SHEET

### Mercury

Distance from the sun: \_\_\_\_\_ million km. Size: \_\_\_\_\_ km.

Mass \_\_\_\_\_ Earth Mass

Axis - Time of rotation: \_\_\_\_\_ Axis - Inclination: \_\_\_\_\_ degrees

Orbit: \_\_\_\_\_ days Orbit speed \_\_\_\_\_ km / h.

### Venus

Distance from the sun: \_\_\_\_\_ million km. Size: \_\_\_\_\_ km.

Mass \_\_\_\_\_ Earth Mass

Axis - Time of rotation: \_\_\_\_\_ Axis - Inclination: \_\_\_\_\_ degrees

Orbit: \_\_\_\_\_ days Orbit speed \_\_\_\_\_ km / h.

### Earth

Distance from the sun: \_\_\_\_\_ million km. Size: \_\_\_\_\_ km.

Mass \_\_\_\_\_ Earth Mass

Axis - Time of rotation: \_\_\_\_\_ Axis - Inclination: \_\_\_\_\_ degrees

Orbit: \_\_\_\_\_ days Orbit speed \_\_\_\_\_ km / h.

### Mars

Distance from the sun: \_\_\_\_\_ million km. Size: \_\_\_\_\_ km.

Mass \_\_\_\_\_ Earth Mass

Axis - Time of rotation: \_\_\_\_\_ Axis - Inclination: \_\_\_\_\_ degrees

Orbit: \_\_\_\_\_ days Orbit speed \_\_\_\_\_ km / h.

**Jupiter**

Distance from the sun: \_\_\_\_\_ million km. Size: \_\_\_\_\_ km.

Mass \_\_\_\_\_ Earth Mass

Axis - Time of rotation: \_\_\_\_\_ Axis - Inclination: \_\_\_\_\_ degrees

Orbit: \_\_\_\_\_ days Orbit speed \_\_\_\_\_ km / h.

**Saturn**

Distance from the sun: \_\_\_\_\_ million km. Size: \_\_\_\_\_ km.

Mass \_\_\_\_\_ Earth Mass

Axis - Time of rotation: \_\_\_\_\_ Axis - Inclination: \_\_\_\_\_ degrees

Orbit: \_\_\_\_\_ days Orbit speed \_\_\_\_\_ km / h.

**Uranus**

Distance from the sun: \_\_\_\_\_ million km. Size: \_\_\_\_\_ km.

Mass \_\_\_\_\_ Earth Mass

Axis - Time of rotation: \_\_\_\_\_ Axis - Inclination: \_\_\_\_\_ degrees

Orbit: \_\_\_\_\_ days Orbit speed \_\_\_\_\_ km / h.

**Neptune**

Distance from the sun: \_\_\_\_\_ million km. Size: \_\_\_\_\_ km.

Mass \_\_\_\_\_ Earth Mass

Axis - Time of rotation: \_\_\_\_\_ Axis - Inclination: \_\_\_\_\_ degrees

Orbit: \_\_\_\_\_ days Orbit speed \_\_\_\_\_ km / h.



## PLANET SPECIFICATIONS ANSWER KEY

### Mercury

Distance from the sun: 57.9 million km      Size: 4 879 km

Mass 0.0553 Earth masses

Axis - Time of rotation: 58.65 d      Axis - Inclination: 0.01 degrees

Orbit: 88 days      Orbit speed 172 440 km / h.

### Venus

Distance from the sun: 108.2 million km      Size: 12 104 km

Mass 0.815 Earth masses

Axis - Time of rotation: 243 d      Axis - Inclination: 177.4 degrees

Orbit: 224.7 days      Orbit speed 126 072 km / h.

### Earth

Distance from the sun: 149.6 million km      Size: 12 756 km

Mass: 1 Earth masses.

Axis - Time of rotation: 23h 56m 4s      Axis - Inclination: 23.5 degrees

Orbit: 365.2 days      Orbit speed 107 280 km / h.

### Mars

Distance from the sun: 227.9 million km      Size: 6 792 km

Mass: 0.107 Earth-masses

Axis - Time of rotation: 24h 37m 23s      Axis - Inclination: 25.2 degrees

Orbit: 687 days      Orbit speed 86 760 km / h.

### **Jupiter**

Distance from the sun: 778.6 million km      Size: 143 984 km

Mass 317.8 Earth-masses

Axis - Time of rotation: 9h 55m 30s    Axis - Inclination: 3.1 degrees

Orbit: 11.86 years                      Orbit speed 47 160 km / h.

### **Saturn**

Distance from the sun: 1 433.5 million km      Size: 120 536 km

Mass 95.2 Earth masses

Axis - Time of rotation: 10h 13m 59s    Axis - Inclination: 26.7 degrees

Orbit: 29.43 years                      Orbit speed 34 920 km / h.

### **Uranus**

Distance from the sun: 2 872.5 million km      Size: 51 118 km

Mass 14.5 Earth masses

Axis - Time of rotation: 17h 14m    Axis - Inclination: 97.8 degrees

Orbit: 83.76 years                      Orbit speed 24 607 km / h.

### **Neptune**

Distance from the sun: 4 495.1 million km      Size: 49 528 km

Mass 17.1 Earth masses

Axis - Time of rotation: 16h 7m    Axis - Inclination: 28.3 degrees

Orbit: 163.7 years                      Orbit speed 19 720 km / h.



**ROYAL CANADIAN AIR CADETS  
PROFICIENCY LEVEL FOUR  
INSTRUCTIONAL GUIDE**



**SECTION 6**

**EO C440.04 – APPLY THE MATERIAL SCIENCE OF TRUSSES**

---

Total Time:	90 min
-------------	--------

---

**PREPARATION**

---

**PRE-LESSON INSTRUCTIONS**

Resources needed for the delivery of this lesson are listed in the lesson specification located in A-CR-CCP-804/PG-001, *Proficiency Level Four Qualification Standard and Plan*, Chapter 4. Specific uses for said resources are identified throughout the instructional guide within the TP for which they are required.

Review the lesson content and become familiar with the material prior to delivering the lesson.

Create slides of Attachments A and B.

For each pair of cadets, construct one suspended container mount (SCM), described at Attachment C, for use in TP 3.

Photocopy the handouts at Attachment C for each pair of cadets.

Obtain one lightweight container for suspension from the SCM, such as a sandwich bag and wire, for incrementally adding marbles when testing the strength of trusses.

**PRE-LESSON ASSIGNMENT**

Nil.

**APPROACH**

An interactive lecture was chosen for TP 1 to generate interest in the material science of trusses and summarize the teaching point.

A practical activity was chosen for TPs 2 and 3 as it is an interactive way to allow the cadets to design and test a truss in a safe and controlled environment.

---

**INTRODUCTION**

---

**REVIEW**

Nil.

**OBJECTIVES**

By the end of this lesson the cadet shall have applied the material science of trusses by constructing and testing a truss.

**IMPORTANCE**

It is important for cadets to apply the material science of trusses as they are a common aerospace structural component due to their light weight and strength.

**Teaching Point 1****Explain the material science of trusses.**

Time: 15 min

Method: Interactive Lecture

Successful structures must withstand the loads and forces that act upon them. When a load (external force), such as gravity or a person's weight, is applied to a structure, forces are produced within the structure (internal forces) to resist the load. Provided the internal forces equal the external forces, the structure will retain its integrity. When imbalances of internal and external forces occur, a structure may suffer a catastrophic failure.

**TYPES OF LOADS**

The two most significant forces on structures are compression and tension. In order for a structure to resist static and dynamic loads, it must be engineered appropriately.

**Static loads.** Loads that remain constant. The weight of the materials from which a structure is made exerts an internal static force on the structure. Gravity is a static load.

**Dynamic loads.** Loads that exert constantly changing forces upon a structure. A car crossing a bridge exerts external dynamic forces on the bridge that must be counteracted by internal forces within the bridge. The structure of the International Space Station (ISS) must resist bending and twisting when it is moved by docking spacecraft or the Canadarm 2.

**PROPERTIES OF MATERIALS**

**Elastic.** Material is considered elastic when it is capable of sustaining deformation without permanent loss of size or shape. Almost all materials have some elastic properties. Glasses and crystals tend to be the least elastic solids whereas organic substances such as rubber and wood tend to show considerable elasticity. Some metals, especially some alloys of iron, can be very elastic.



Show the cadets Figure A-1 located at Attachment A.

**Plastic.** If a substance is compressed or stretched beyond a certain limit (called its elastic limit) it begins to exhibit plastic-like properties and it will become permanently deformed. Once a material is stretched or compressed beyond its elastic limit it is said to enter a plastic phase.



Show the cadets Figure A-2 located at Attachment A.



The word "plastic" in this case refers to the physical properties of the material, NOT the substance(s) we call "plastic"—which is the common term for a wide range of synthetic or semisynthetic organic solid materials used in the manufacture of products.

Materials that have plasticity may exhibit either of the following:

- **Malleability.** The material is capable of undergoing plastic deformation without rupture, especially metals.
- **Ductility.** The ability of a material to be plastically deformed by elongation without fracture.

All materials have some degree of elasticity and plasticity, but when a material fractures easily it is said to be brittle. A material is brittle if it is liable to fracture when subjected to stress. It has little tendency to deform (or strain) before fracture. This fracture absorbs relatively little energy, even in materials of high strength, and usually makes a snapping sound.



Show the cadets Figure A-3 located at Attachment A.

## APPLIED FORCE

The effects of applying force can be illustrated on a cube of material. The side view of the cube is shown as the shape of a square. When no external forces are present the cube is considered in a neutral state.



Show the cadets Figure A-4 located at Attachment A.

When external forces are applied while the cube remains stationary (eg, the cube does not accelerate under the application of the applied force) it is said to be in a non-neutral condition of which there are several possibilities.

**Compression.** If the cube is supported from below so that it is unable to move, while a downward force is applied on the top of the cube, the cube is said to be in a state of compression. In this state, the cube tends to deform, becoming slightly shorter and wider.



Show the cadets Figure A-5 located at Attachment A.

If the material from which the cube is made is elastic, it will return to its original shape when the compressing force is removed. If the material from which the cube is made is plastic and non-elastic, it will undergo permanent deformation. When the material is long and thin, compressive forces can cause buckling, where the material fails due to elastic instability.



Show the cadets Figure A-6 located at Attachment A.

**Tension.** If the cube is securely fastened at its lower surface (perhaps glued to the surface upon which it is sitting) and an upward force is applied to its upper surface, the cube is said to be in a state of tension. The effect is to make the cube stretch upward while contracting inward around its sides.



Show the cadets Figure A-7 located at Attachment A.

If the material from which the cube is made is elastic, it will return to its original shape when the tensile (stretching) force is removed. If the material from which the cube is made is plastic and non-elastic, it will undergo permanent deformation.



Show the cadets Figures A-8 and A-9 located at Attachment A.

**Shear.** If the cube deforms as illustrated in Figure A-8, it is called shear. If the material from which the cube is made is elastic, it will return to its original shape when the shearing force is removed. If the material from which the cube is made is plastic and non-elastic it will undergo permanent deformation.

**Shear stress.** When forces are applied in such a way that the different parts of the cube try to slide with respect to one another, the effect is also called shearing. If parts of the cube try to slide, it is called shear stress.



Show the cadets Figure A-10 located at Attachment A.

**Torsion.** Torsion is the twisting of an object due to an applied torque. If the top of the cube is rotated while the bottom is fixed, the cube will twist.

---

## CONFIRMATION OF TEACHING POINT 1

### QUESTIONS:

- Q1. What is a static load on a structure?
- Q2. What happens to an object under tension?
- Q3. What will torque do to an object?

### ANTICIPATED ANSWERS:

- A1. A load that remains constant.
- A2. The object will stretch while contracting inward around its sides.
- A3. It will twist the object.

---

**Teaching Point 2****Have the cadets, in pairs, design a truss.**

Time: 15 min

Method: Practical Activity

---

**Truss.** Any of various structural frames based on the geometric rigidity of the triangle and composed of straight members connected at joints referred to as nodes, subject only to longitudinal compression, tension, or both. At a minimum, a truss will have three members and three nodes. Trusses offer the most strength using the least weight: an important factor in spacecraft design.



Show the cadets Figures B-1 and B-2 located at Attachment B.

A planar truss is one where all the members and nodes lie within a two dimensional plane. A space truss has members and nodes extending into three dimensions.

When designing a truss, consider the following:

- effect of tension versus compression on member sizes and lengths;
- approaches to preventing potential buckling failure modes;
- potential for stress reversal; and
- overall lateral stability (lateral-torsional buckling).

The first step in constructing a truss is to understand what the truss will be used for and what forces will be placed on the truss. When the parameters have been established, putting the design on paper or using computer aided design (CAD) software will save time and material.

The truss will be tested by applying weight at its centre via the suspended container mount. Weight will be added until the truss fails. This test will demonstrate one aspect of truss design as it is an application of only one force on the truss.



Distribute the handout of Attachment C to each cadet.

---

**ACTIVITY**

Time: 10 min

**OBJECTIVE**

The objective of this activity is to have the cadets, in pairs, design a truss to be constructed out of uncooked spaghetti and hot glue.



## RESOURCES

Material required by each pair of cadets:

- Photocopy of Attachment C,
- One legal size graph paper pad,
- Two mechanical pencils,
- One eraser,
- One 30-cm ruler,
- One plastic protractor, and
- 24 unbroken strands of uncooked spaghetti.

## ACTIVITY LAYOUT

Nil.

## ACTIVITY INSTRUCTIONS

1. Distribute the required material to each pair of cadets.
2. Have each pair of cadets design a truss.



The truss will be constructed out of uncooked spaghetti and hot glue. When designing the truss keep these factors in mind:

- The truss will be assessed on its strength to weight ratio. A light truss that supports the same weight as a heavy truss will be assessed a higher value.
- The buckling point of a member is related to its length. The longer the member, the greater the chance of buckling. Shorter pieces of spaghetti are better in compression. Long strands of spaghetti are stronger in tension than they are in compression.
- The suspended container mount consists of a block of plywood with a screw eye in its centre and is used to hold the suspended container of marbles. Be precise with the suspended container mount position and dimensions. All the weight that the truss will carry is supported by this mount.
- Truss members can be made up of more than one strand of spaghetti.
- The truss will be supported on each end by an abutment, represented by tables set 45 cm apart.

## SAFETY

Nil.

---

## CONFIRMATION OF TEACHING POINT 2

The cadets' participation in the activity will serve as the confirmation of this TP.

---

**Teaching Point 3****Have the cadets, in pairs, construct and test a truss.**

Time: 50 min

Method: Practical Activity

---



The truss testing is a competition between the pairs of cadets and not an assessment.

The truss construction should follow the design as closely as possible. Points will be lost for trusses that do not follow the original design or that waste material. Points will be gained for construction technique and neatness.

The suspended container will be filled with marbles. When the truss fails, the amount of marbles in the suspended container will be counted and divided by the weight of the bridge. This ratio will be used in the total score.

Neatness counts!

---

**ACTIVITY**

Time: 45 min

**OBJECTIVE**

The objective of this activity is to have the cadets, in pairs, construct and test a truss.

**RESOURCES**

Material required by each pair of cadets:

- Suspended container mount,
- Glue gun,
- Hot glue sticks,
- Hobby knife, and
- Uncooked spaghetti.

**ACTIVITY LAYOUT**

Nil.

**ACTIVITY INSTRUCTIONS**

1. Distribute the materials to each pair of cadets.
2. Have the cadets, within 35 minutes, use their truss designs from TP 2 to construct the truss.
3. Have the cadets test their trusses for the remaining 10 minutes.
4. Use the scoring sheet at Attachment C to record the test results.



Hot glue is hot enough to cook the spaghetti, which will result in a weakened node or member. Apply only a small amount of heat and glue to connect the members.

### **SAFETY**

Use caution with the hot glue gun and glue. The glue and gun can reach 120–195 degrees Celcius. This is hot enough to burn flesh.

---

### **CONFIRMATION OF TEACHING POINT 3**

The cadets' participation in the activity will serve as the confirmation of this TP.

---

### **END OF LESSON CONFIRMATION**

This lesson should be taught in three consecutive periods.

The cadets' construction of a truss will serve as the confirmation of this lesson.

---

### **CONCLUSION**

---

### **HOMEWORK / READING / PRACTICE**

Nil.

### **METHOD OF EVALUATION**

Nil.

### **CLOSING STATEMENT**

Although the International Space Station is made largely of aluminum instead of spaghetti, it is an application of the material science of trusses, using the same principles as any truss.

### **INSTRUCTOR NOTES / REMARKS**

Cadets who qualified Advanced Aerospace may assist with this instruction.

---

### **REFERENCES**

C3-331 McMaster University YES I Can! Science Team. (2009). *How forces act on structures*. Retrieved February 19, 2009, from <http://resources.yesican-science.ca/sts115/aboutforces.html>

THIS PAGE INTENTIONALLY LEFT BLANK

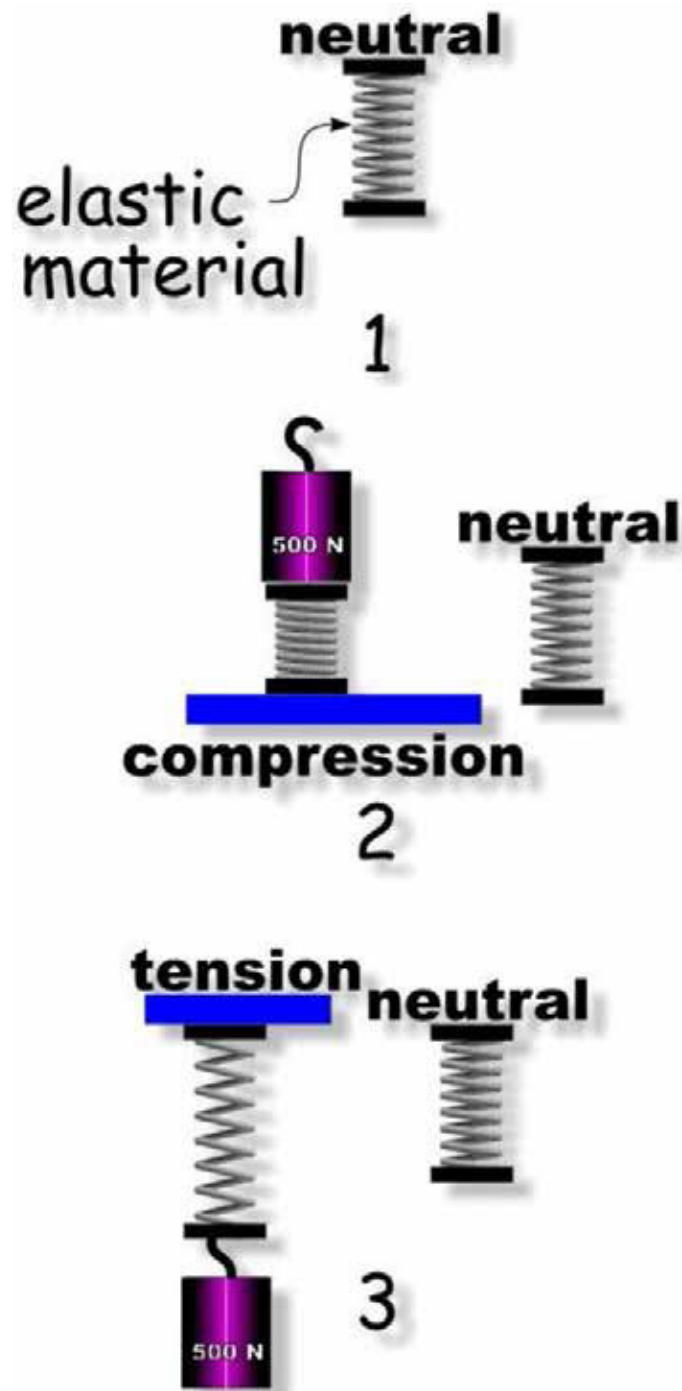

Figure A-1 Elastic Material

*Note.* From "Materials, Structures, and Forces", 2008, *Structures in Space*. Retrieved November 20, 2008, from <http://resources.yesican-science.ca/sts115/aboutforces.html>

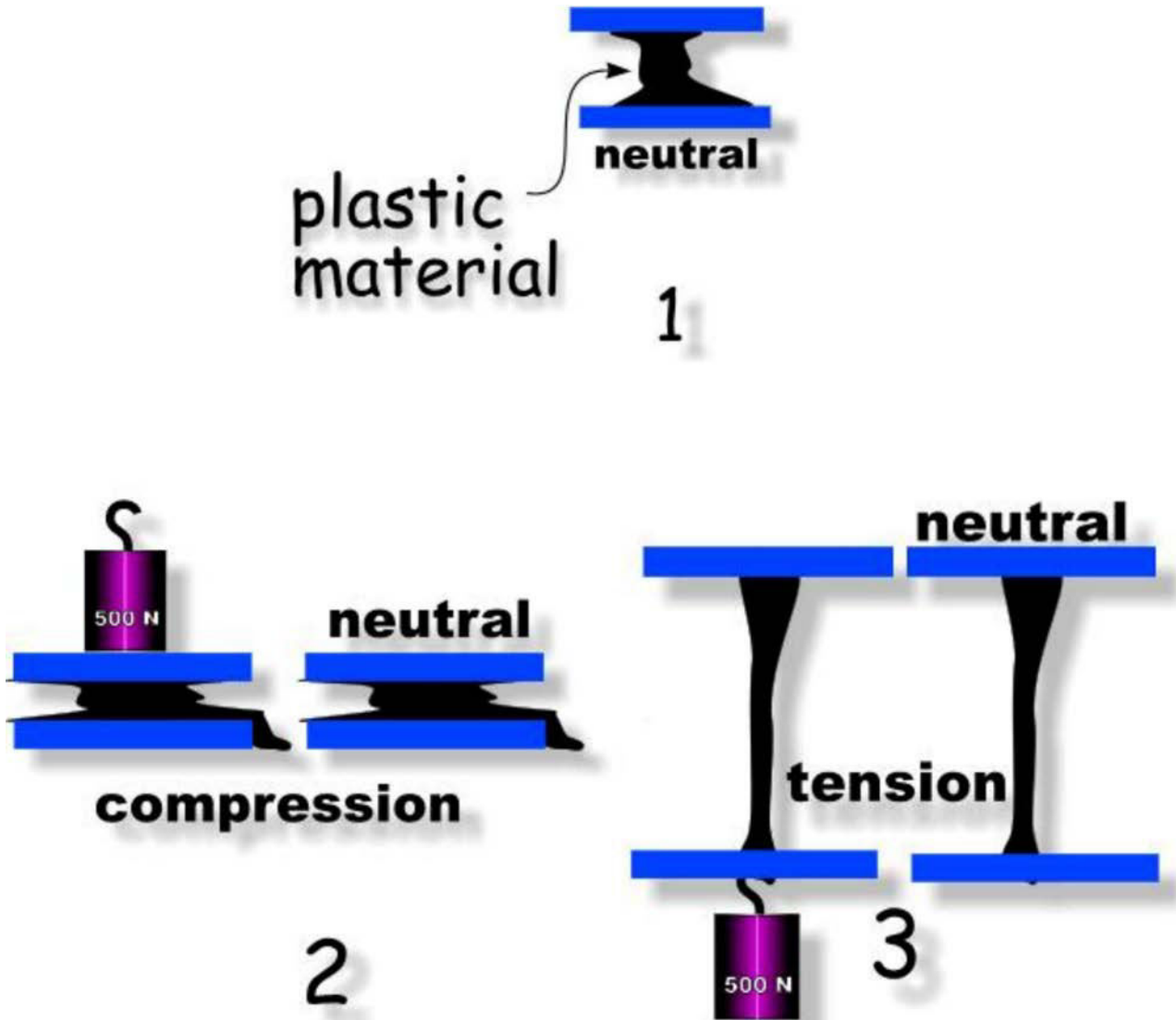

Figure A-2 Plastic Material

Note. From "Materials, Structures, and Forces", 2008, *Structures in Space*. Retrieved November 20, 2008, from <http://resources.yesican-science.ca/sts115/aboutforces.html>

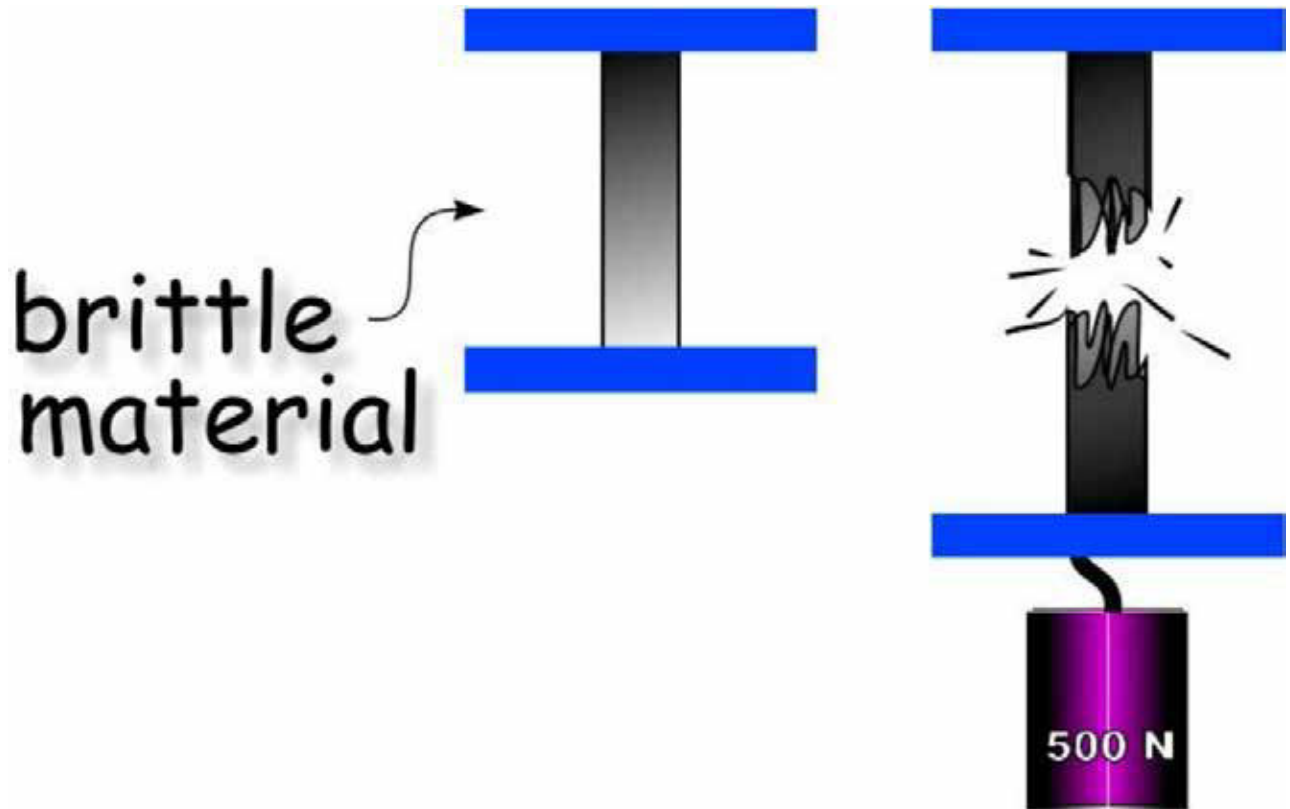
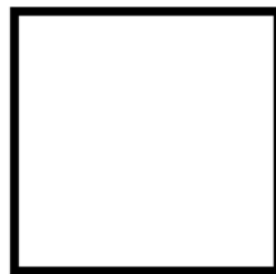

Figure A-3 Brittle Material

*Note.* From "Materials, Structures, and Forces", 2008, *Structures in Space*. Retrieved November 20, 2008, from <http://resources.yesican-science.ca/sts115/aboutforces.html>



neutral

Figure A-4 Cube at Rest

*Note.* From "Materials, Structures, and Forces", 2008, *Structures in Space*. Retrieved November 20, 2008, from <http://resources.yesican-science.ca/sts115/aboutforces.html>

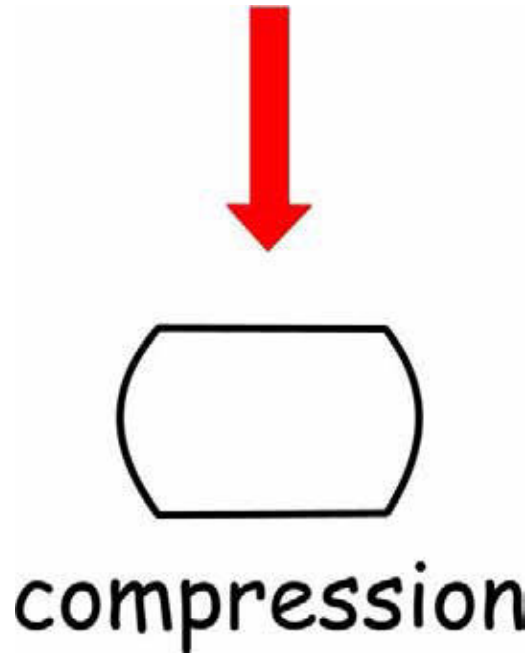

Figure A-5 Cube in Compression

*Note.* From "Materials, Structures, and Forces", 2008, *Structures in Space*. Retrieved November 20, 2008, from <http://resources.yesican-science.ca/sts115/aboutforces.html>

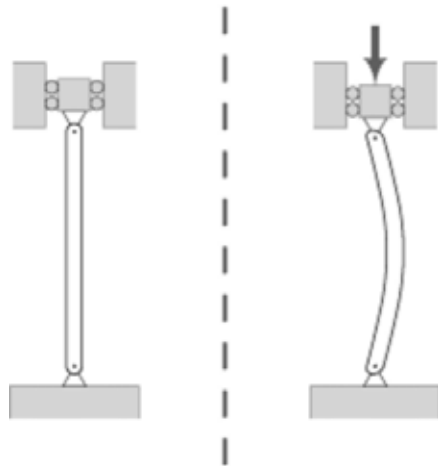

Figure A-6 Compression Causing Buckling

*Note.* From "Buckling", 2008. Retrieved November 25, 2008, from <http://en.wikipedia.org/wiki/Buckling>



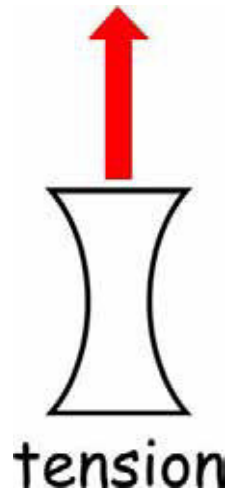

Figure A-7 Cube in Tension

*Note.* From "Materials, Structures, and Forces", 2008, *Structures in Space*. Retrieved November 20, 2008, from <http://resources.yesican-science.ca/sts115/aboutforces.html>

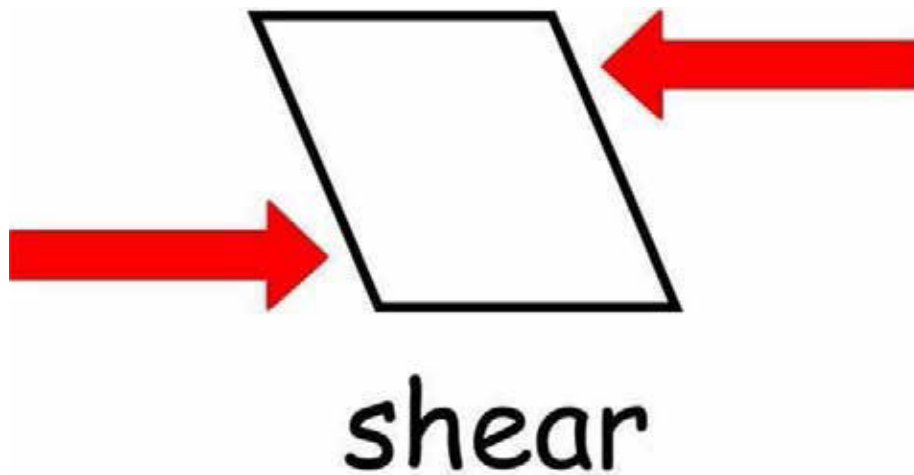
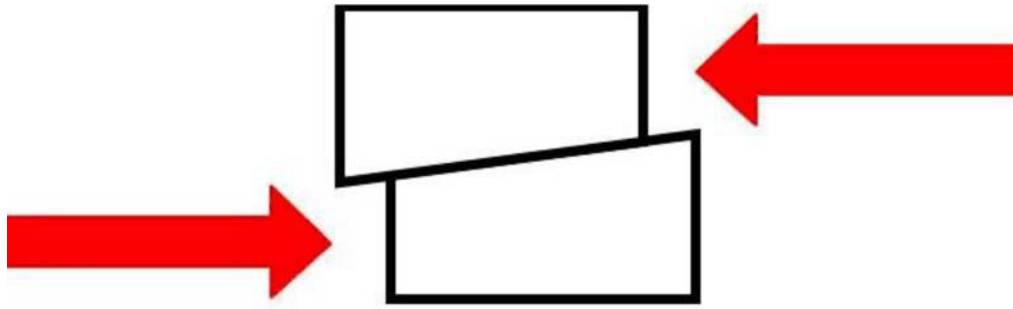

Figure A-8 Cube in Shear

*Note.* From "Materials, Structures, and Forces", 2008, *Structures in Space*. Retrieved November 20, 2008, from <http://resources.yesican-science.ca/sts115/aboutforces.html>



## shear (stress)

Figure A-9 Cube Shear Stress

*Note.* From "Materials, Structures, and Forces", 2008, *Structures in Space*. Retrieved November 20, 2008, from <http://resources.yesican-science.ca/sts115/aboutforces.html>



Figure A-10 Cube in Torsion

*Note.* From "Cube Twist", 2008. Retrieved November 25, 2008, from [http://www.helleronline.com/fgfc1\\_main.php?&color=silver&view=front](http://www.helleronline.com/fgfc1_main.php?&color=silver&view=front)

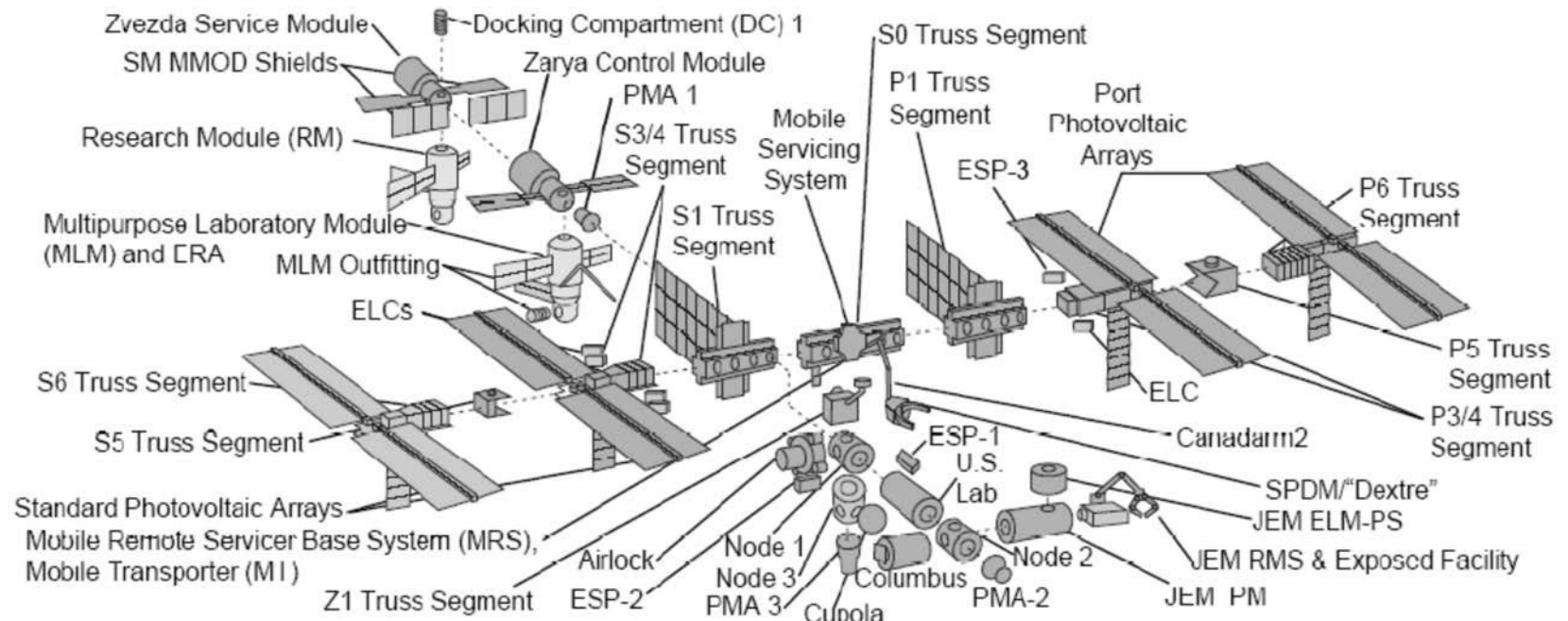

Figure B-1 Exploded View of the ISS Truss Structure

Note. From "Space Exploration", Boeing, 2008, *International Space Station Backgrounder*, Boeing. Retrieved February 19, 2009, from [http://www.boeing.com/defense-space/space/spacestation/docs/ISS\\_overview.pdf](http://www.boeing.com/defense-space/space/spacestation/docs/ISS_overview.pdf)

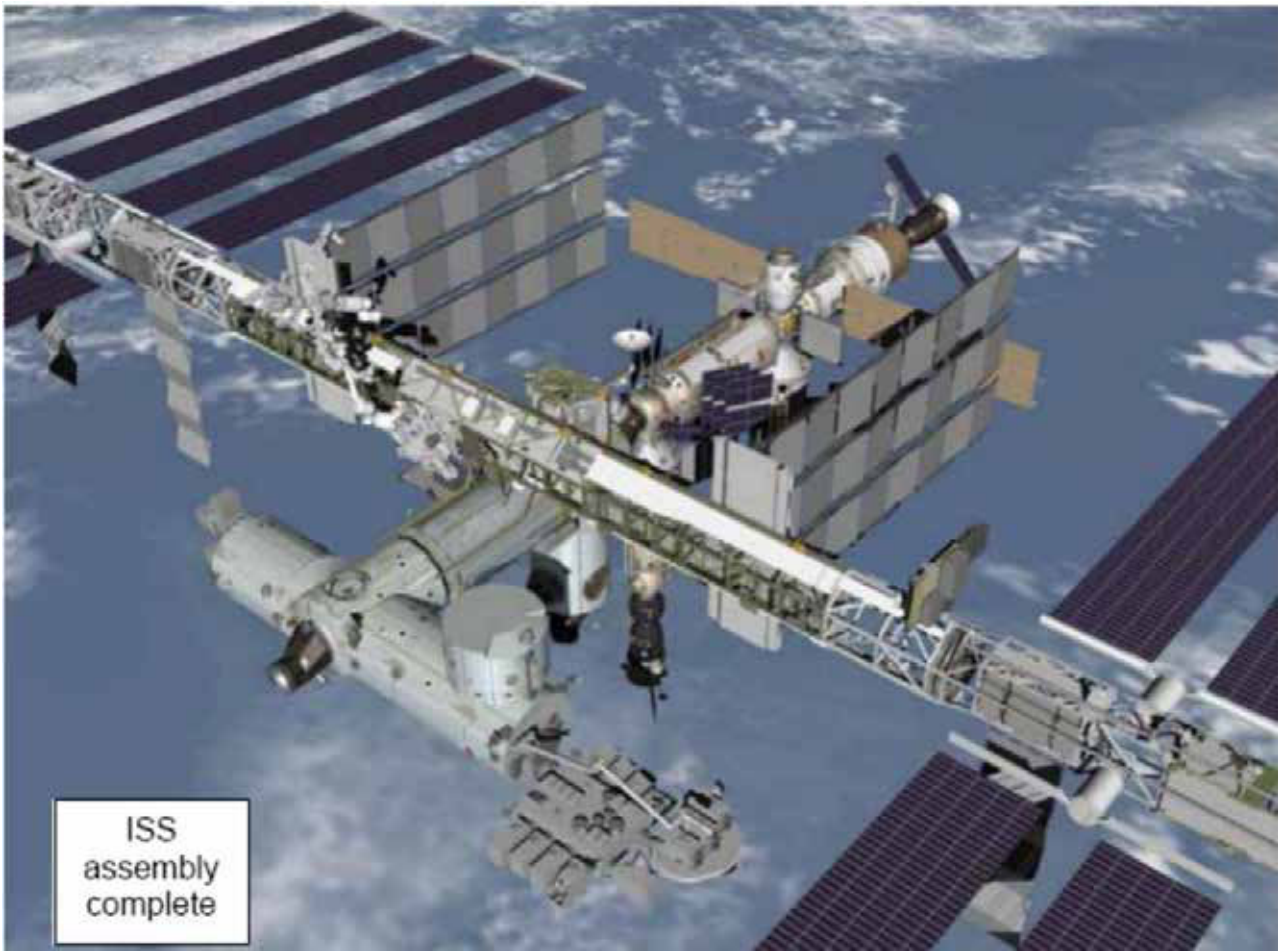

Figure B-2 ISS Truss Structure

Note. From "Space Exploration", Boeing, 2006, *International Space Station Backgrounder*, Boeing. Retrieved November 25, 2008, from [http://www.boeing.com/defense-space/space/spacestation/docs/ISS\\_overview.pdf](http://www.boeing.com/defense-space/space/spacestation/docs/ISS_overview.pdf)

## TRUSS COMPETITION

### Rules and Regulations

Trusses must be constructed of materials provided by the squadron training office. No other materials may be used in the construction of the truss.

Material required by each pair of cadets includes:

- Spaghetti (uncooked, 25 cm long),
- Hot glue gun, and
- Glue sticks.

Parameters for the competition are:

- distance between the abutments: 45 cm,
- length: not less than 47 cm, not greater than 55 cm,
- width: not greater than 10 cm,
- height: not greater than 25 cm,
- no part of the truss will hang below the top of the abutments, and
- time: 40 min.

The provided suspended container mount (SCM) shall be incorporated into the truss. The SCM consists of the following materials:

- 2-cm eye bolt, and
- 8 cm by 8 cm birch plywood square, 4 mm thick.

The following criteria will be used for scoring:

- design,
- quality of construction,
- material use / waste, and
- amount of marbles divided by the weight of the truss.

**TRUSS TESTING SCORING SHEET**

Cadet Pair	Follows Design <sup>1</sup>	Quality of Construction <sup>2</sup>		Length <sup>4</sup>	Width <sup>5</sup>	Height <sup>6</sup>	Amount of Marbles	Weight of Truss	Ratio <sup>7</sup>	Total
			Material Use <sup>3</sup>							
	1/0	1/0	1/0	1/0	1/0	1/0				
	1/0	1/0	1/0	1/0	1/0	1/0				
	1/0	1/0	1/0	1/0	1/0	1/0				
	1/0	1/0	1/0	1/0	1/0	1/0				
	1/0	1/0	1/0	1/0	1/0	1/0				

**Note:**

1. One point for following design; no points for not following design.
2. One point for neat construction; no points for messy construction.
3. One point for minimum waste; no points for wasting material.
4. Subtract one point for over or under 47–55 cm.
5. Subtract one point for over 10 cm.
6. Subtract one point for over 25 cm.
7. Divide the number of marbles in the suspended container by the bridge weight for this ratio.



**ROYAL CANADIAN AIR CADETS  
PROFICIENCY LEVEL FOUR  
INSTRUCTIONAL GUIDE**



**SECTION 7**

**EO C440.05 – DESCRIBE ROBOTICS**

Total Time:

30 min

**PREPARATION**

**PRE-LESSON INSTRUCTIONS**

Resources needed for the delivery of this lesson are listed in the lesson specification located in A-CR-CCP-804/PG-001, *Proficiency Level Four Qualification Standard and Plan*, Chapter 4. Specific uses for said resources are identified throughout the instructional guide within the TP for which they are required.

Review the lesson content and become familiar with the material prior to delivering the lesson.

Create slides of the figures located at Attachments A–C.

**PRE-LESSON ASSIGNMENT**

Nil.

**APPROACH**

An interactive lecture was chosen for this lesson to give the cadets an overview of robotics and generate interest in the subject.

**INTRODUCTION**

**REVIEW**

Nil.

**OBJECTIVES**

By the end of this lesson the cadet shall have described robotics and shall be expected to identify types of robots.

**IMPORTANCE**

It is important for cadets to be familiar with robot types and various robotic applications because they form an important and growing aspect of the aerospace industry in both manufacturing and operations.

**Teaching Point 1****Describe types of robots.**

Time: 10 min

Method: Interactive Lecture

A robot is defined as a machine that looks and functions like a human being. A robot is also defined as a machine that is capable of carrying out a complex series of tasks automatically. Some organizations provide special definitions of a robot, such as those found at NASA's ROVER Ranch website, which include:

- a machine that looks like a human being and performs various complex acts similar to those of a human being (such as walking or talking);
- a device that automatically performs complicated, often repetitive, tasks; and
- any mechanism guided by automatic controls.



NASA's ROVER Ranch is a place to learn about robotic engineering at <http://prime.jsc.nasa.gov/ROV/>

**AUTONOMOUS SYSTEMS**

Autonomous systems are the physical embodiment of machine intelligence. This means that an autonomous system combines artificial intelligence (AI) with the manipulating abilities of remote-controlled systems.

**REMOTE-CONTROLLED SYSTEMS**

The earliest robots, such as the armoured robot knight created by Leonardo da Vinci in 1495, did not think for themselves. Representing the technology of 1495, Leonardo da Vinci's robot consisted of two independent systems:

- three-degree-of-freedom legs, ankles, knees, and hips; and
- four-degree-of-freedom arms with articulated shoulders, elbows, wrists, and hands.



Examples of Degrees of Freedom (DOF) are:

- tilting forward and backward (pitching);
- turning left and right (yawing);
- tilting side to side (rolling);
- moving up and down (heaving);
- moving left and right (swaying); and
- moving forward and backward (surging).



Show the cadets the slide of Figures A-1 and A-2 located at Attachment A.



The orientation of the arms on Leonardo's robot indicates that it was designed for whole-arm grasping, which means that all the joints moved in unison. A mechanical, analog-programmable controller within the chest provided power and control for the arms.

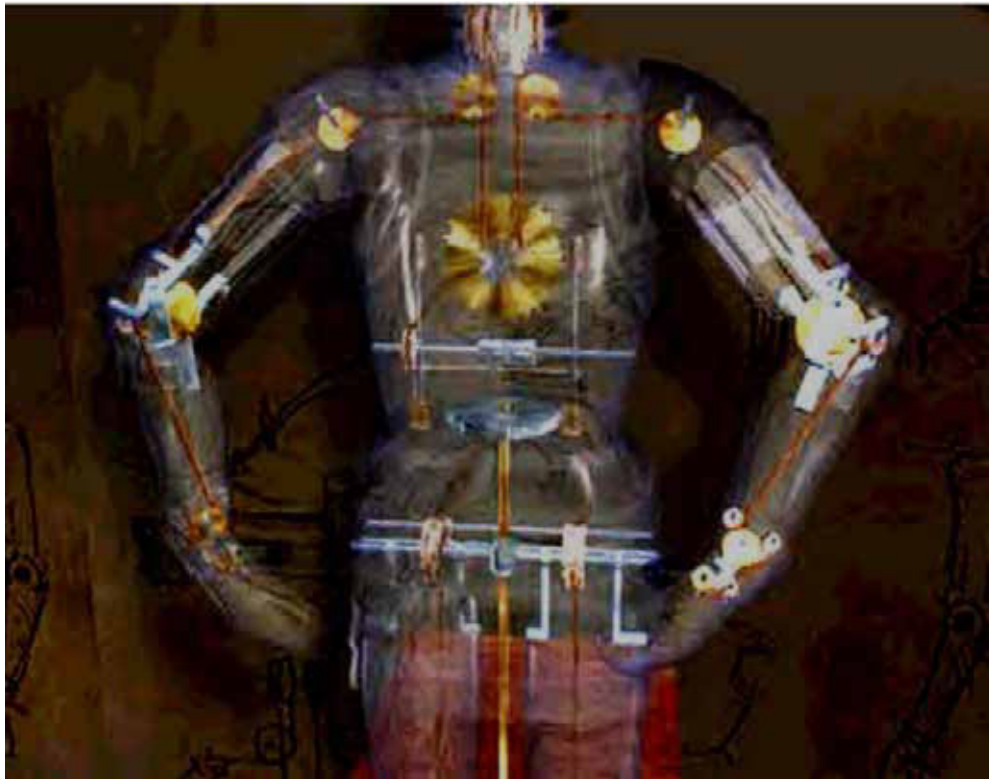

Figure 1 Leonardo's Mechanical Analog-Programmable Controller

*Note.* From "Z-Kat the Digital Surgery Company", by R. Abovitz, 2001, *Leonardo's Robot*, Copyright 2008 by R. Abovitz. Retrieved November 18, 2008, from [http://www.z-kat.com/company/adv\\_research/leonardo.shtml](http://www.z-kat.com/company/adv_research/leonardo.shtml)

The legs were powered by an external crank arrangement driving the cable, which was connected to key locations in the ankle, knee, and hip. This armoured robot knight was designed to sit up, wave its arms, and move its head via a flexible neck while opening and closing its anatomically correct jaw. It may have made sounds to the accompaniment of automated drums. On the outside, the robot is dressed in a typical German-Italian suit of armour of the late fifteenth century.



Modern robots such as the Canadarm and the Canadarm2 combine the two modes of remote control and autonomy.

### **Canadarm: Shuttle Remote Manipulator System (SRMS)**

The space shuttle's general-purpose computer (GPC) controls the movement of the SRMS. The astronauts use a hand controller, which tells the computer what the astronaut would like the arm to do. Built-in software then studies the astronaut's commands and calculates which joints should move, what direction to move them in, how fast to move them and at what angle to move.



Show the cadets the slide of Figure A-3 located at Attachment A.

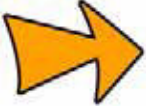

Figure A-3 is a scale drawing of the Canadarm.

While the computer is issuing commands to each of the joints, it monitors each joint every 80 milliseconds. Any movements of the astronaut's hand are re-examined and recalculated by the GPC and updated commands are then sent out to each of the joints.

Should a failure occur, the GPC automatically applies the brakes to all joints and notifies the astronaut of a failure condition. The control system also provides a continuous display of joint rates and speeds, which are displayed on monitors located on the flight deck of the shuttle. As with any control system, the GPC can be overridden and the astronaut can operate the joints individually from the flight deck.

---

### CONFIRMATION OF TEACHING POINT 1

#### QUESTIONS:

- Q1. What are autonomous systems?
- Q2. What two modes do robots such as the Canadarm and the Canadarm2 combine?
- Q3. What computer controls the SRMS?

#### ANTICIPATED ANSWERS:

- A1. Autonomous systems are the physical embodiment of machine intelligence.
- A2. The two modes combined in the Canadarm and the Canadarm2 are remote control and autonomy.
- A3. The space shuttle's general-purpose computer (GPC) controls the movement of the SRMS.

---

### Teaching Point 2

### Describe robotic applications.

Time: 15 min

Method: Interactive Lecture

Robots are especially desirable for certain work functions because, unlike humans, they:

- never get tired;
- can endure physical conditions that are uncomfortable, dangerous or even airless;
- do not get bored by repetition; and
- cannot be distracted from the task at hand.

Early industrial robots that handled radioactive material in atomic labs were called master / slave manipulators. They were connected with mechanical linkages and steel cables. Remote arm manipulators can now be moved by push buttons, switches or joysticks.

Robots sometimes have advanced sensory systems that process information and appear to function as if they have brains. Their "brain" is actually a form of computerized AI, which allows a robot to perceive conditions and decide on a course of action based on these conditions.

A robot may include any of the following components:

- **Effectors.** "Arms", "legs", "hands", "feet".
- **Sensors.** Parts that act like senses, can detect objects or things like heat and light and convert the information into symbols that computers understand.
- **Computer.** The brain that contains instructions called algorithms to control the robot.
- **Equipment.** Includes tools and mechanical fixtures.

Characteristics that make autonomous robots different from regular machinery are that they usually function by themselves, are sensitive to their environment, adapt to variations in the environment or to errors in prior performance, are task-oriented and often have the ability to try different methods to accomplish a task.

## INDUSTRIAL FABRICATION

Typical industrial robots do jobs that are difficult, dangerous or dull. They lift heavy objects, paint, handle chemicals, and perform assembly work. They perform the same job hour after hour, day after day with precision. They do not get tired and they do not make errors associated with fatigue and are ideally suited to performing repetitive tasks.

The major categories of industrial robots, differentiated by mechanical structure are:

- **Cartesian / Gantry robot.** Used for pick and place work, application of sealant, assembly operations, handling machine tools and arc welding. It is a robot whose arm has three joints and whose axes are coincident with Cartesian coordinates on X, Y and Z axes.



Show the cadets the slide of Figures B-1 and B-2 located at Attachment B.

- **Cylindrical robot.** Used for assembly operations, handling machine tools, spot welding, and handling die-casting machines. It is a robot whose axes form a cylindrical coordinate system.



Show the cadets the slide of Figure B-3 located at Attachment B.

- **Polar (Spherical) robot.** Used for handling machine tools, spot welding, die-casting, fettling machines, gas welding and arc welding. It is a robot whose axes form polar coordinates.



Show the cadets the slide of Figure B-4 located at Attachment B.

- **SCARA robot.** Used for pick and place work, application of sealant, assembly operations and handling machine tools. It is a robot that has two parallel rotary joints to provide compliance in a plane.



Show the cadets the slide of Figure B-5 located at Attachment B.

- **Articulated robot.** Used for assembly operations, die-casting, fettling machines, gas welding, arc welding and spray painting. It is a robot whose arm has at least three rotary joints.



Show the cadets the slide of Figure B-6 located at Attachment B.

- **Parallel robot.** One use is a mobile platform handling cockpit flight simulators. It is a robot whose arms have concurrent prismatic or rotary joints.



Show the cadets the slide of Figures B-7 and B-8 located at Attachment B.

## Machining

Computer Numerical Control (CNC) refers to a computer controller that reads computer code instructions and drives a machine tool—a powered mechanical device typically used to fabricate components by the selective removal of material from a larger block of material. The operating parameters of the CNC are altered by changing the software, making CNC machines a type of robot.

## Cutting

The most common methods of cutting used by robots are plasma cutting and oxyfuel cutting.

Plasma cutting is a process that uses a high velocity jet of ionized gas delivered from a constricting orifice. Plasma cutting takes place when a high-velocity stream of gas (plasma) is forced through a narrow torch. Plasma cutting can be performed on any type of conductive metal—mild steel, aluminum and stainless steel are some examples.

Oxyfuel cutting is a process that cuts by burning, or oxidizing, the metal it is severing. It is therefore limited to steel and other ferrous metals that support the oxidizing process.

## Assembling

Assembly robots have expanded production capabilities in the manufacturing world, making the assembly process faster, more efficient and more precise than ever before. Robots have saved workers from tedious and dull assembly line jobs, and increased production and savings in the process. One class of assembly robot is the Selective Compliant Articulated Robot for Assembly (SCARA) Robot.



Show the cadets the slide of Figure B-5 located at Attachment B.

The work characteristics of robots give them several advantages for industrial assembly, including:

- **No fatigue.** An assembly robot can work every day, every hour without pause.
- **More output.** The consistent output of a robotic system along with quality, and repeatability are unmatched even with the most challenging of applications.
- **Better performance.** Automated systems provide precise, exact performance. Many of them are equipped with vision technology to aid in production.
- **Savings.** Robot assembly systems create savings by eliminating downtime and labour costs, while increasing production and performance.

## Welding

There are two popular types of industrial welding robots; Articulating and Cartesian.

- **Articulating robots.** Employ arms and rotating joints. These robots move like a human arm with a rotating wrist at the end. This creates an irregularly shaped robotic working zone.
- **Cartesian robots.** Move in line in any of three axes (X, Y, Z). In addition to linear movement of the robot along axes there is a wrist attached to the robot to allow rotational movement. This creates a robotic working zone that is box shaped.

## EXPLORING

### Underwater Exploration



Show the cadets the slide of Figure C-1 located at Attachment C.

A seaglider is an Autonomous Underwater Vehicle (AUV) that measures temperature, salinity, depth-averaged current and other quantities in the ocean. A seaglider uses satellite data telemetry to receive commands and send the measurements it collects in near-real time. A seaglider AUV collects ocean physical properties across a range of depths and areas for oceanographers and military planners.

### Deep Space 1 (DS1)

Launched in October 1998, Deep Space 1 (DS1) was the first mission of NASA's new millennium program, chartered to validate new technologies important for future space and earth science programs. The advanced technology payload that was tested on DS1 included a solar-powered Ion Propulsion System (IPS), solar concentrator arrays, an autonomous on-board optical navigation system and an autonomous artificial intelligence (AI) system known as Remote Agent.



Show the cadets the slide of Figure C-2 located at Attachment C.



Figure C-2 shows DS1 trajectory: The dotted portion of the trajectory shows where the DS1 was coasting (ballistic flight) and the solid portion indicates where the IPS thrust was turned on, accelerating the spacecraft.

The autonomous optical navigation system on board DS1 used images of asteroids and stars collected by the onboard camera system, while the onboard navigator system computed and corrected the spacecraft's course.

The autonomous operations system was composed of an AI "agent" that planned, made decisions, and operated by itself.

## SPACE

Space-based robotic technology falls within the following three broad mission areas:

- exploration robotics,
- science payload maintenance, and
- on-orbit servicing.

Important robotic devices proven in space include:

- Remotely Operated Vehicle (ROV) such as the Mars Exploration Rovers, and
- Remote Manipulator System (RMS) such as the Canadarm.

An ROV can be an unmanned spacecraft that remains in flight, a lander that lands on a body such as a moon, asteroid or planet and operates from a stationary position, or a rover that can move over terrain once it has landed. One of the best known ROV's is the Sojourner rover that was deployed by the Mars Pathfinder spacecraft.



Show the cadets the slide of Figure C-3 located at Attachment C.

## EMERGENCY SERVICES

Robots can resolve high-risk scenarios safely, including bomb disposal, hostage situations, search and rescue and other dangerous incidents. Robots can detect explosive vapors and particulates emanating from munitions and Improvised Explosive Devices (IEDs) while keeping the operator and civilians out of harm's way. They can drive to and reach through windows, under vehicles and around obstructing objects and place ultra-sensitive explosive detectors close to suspicious packages and other potentially dangerous items.

## MILITARY

Robots can carry heavy payloads, travel over rough terrain and climb stairs while maintaining full mobility. When equipped with appropriate equipment, they can support a variety of critical missions, including:

- battlefield casualty extraction,
- Explosive Ordnance Disposal (EOD),
- vehicle-borne Improvised Explosive Device (IED) detection,
- physical security,
- firefighting,
- Special Weapons And Tactics (SWAT),
- reconnaissance,
- hazardous material handling,
- chemical-biological weapon detection,
- building clearance,
- target acquisition, and
- weaponized missions.

### Sniper Detection



Show the cadets the slide of Figure C-4 located at Attachment C.

By providing superior situational awareness, a robot can support safer ground troop movement. It can find the point of hostile gunfire without exposing ground troops, allowing them to move more safely.

## CONFIRMATION OF TEACHING POINT 2

### QUESTIONS:

- Q1. What are two properties of robots that make them especially desirable for certain jobs?
- Q2. What was the name of the AI on DS1?
- Q3. Name three possible military missions for robots.

### ANTICIPATED ANSWERS:

- A1. Properties of robots that make them especially desirable for certain jobs include:
  - robots never get tired;
  - robots can endure physical conditions that are uncomfortable or even dangerous;
  - robots operate in airless conditions;

- robots do not get bored by repetition; and
- robots cannot be distracted from the task at hand.

A2. Remote agent.

A3. Possible military missions for robots include:

- battlefield casualty extraction,
- EOD,
- vehicle-borne IED detection,
- physical security,
- firefighting,
- SWAT,
- reconnaissance,
- hazardous material handling,
- chemical-biological weapon detection,
- building clearance,
- target acquisition, and
- weaponized missions.

---

## END OF LESSON CONFIRMATION

### QUESTIONS:

- Q1. What two modes do robots such as the Canadarm and the Canadarm2 combine?
- Q2. What characteristics make autonomous robots different from regular machinery?
- Q3. What are five applications of robots?

### ANTICIPATED ANSWERS:

- A1. Remote control and autonomy.
- A2. Characteristics that make autonomous robots different from regular machinery are that they:
- usually function by themselves;
  - are sensitive to their environment;
  - adapt to variations in the environment or to errors in prior performance;
  - are task oriented; and
  - have the ability to try different methods to accomplish a task.
- A3. Industrial fabrication, exploration, space, emergency services, and military.



---

**CONCLUSION**

---

**HOMEWORK / READING / PRACTICE**

Nil.

**METHOD OF EVALUATION**

Nil.

**CLOSING STATEMENT**

Robots and various robotic applications are encountered every day in every walk of life. They form an important and growing aspect of the aerospace industry in both manufacturing and operations.

**INSTRUCTOR NOTES / REMARKS**

Cadets who are qualified Advanced Aerospace may assist with this instruction.

---

**REFERENCES**

---

C3-292 NASA. (2003). *Rover ranch: K-12 experiments in robotic software*. Retrieved November 20, 2008, from <http://prime.jsc.nasa.gov/ROV/>

THIS PAGE INTENTIONALLY LEFT BLANK



Figure A-1 Leonardo da Vinci's Robot Drawing

*Note.* From "Z-Kat the Digital Surgery Company", by R. Abovitz, 2001, *Leonardo's Robot*, Copyright 2008 by R. Abovitz. Retrieved November 18, 2008, from [http://www.z-kat.com/company/adv\\_research/leonardo.shtml](http://www.z-kat.com/company/adv_research/leonardo.shtml)



Figure A-2 Leonardo da Vinci's Robot

*Note.* From "Z-Kat the Digital Surgery Company", by R. Abovitz, 2001, *Leonardo's Robot*, Copyright 2008 by R. Abovitz. Retrieved November 18, 2008, from [http://www.z-kat.com/company/adv\\_research/leonardo.shtml](http://www.z-kat.com/company/adv_research/leonardo.shtml)

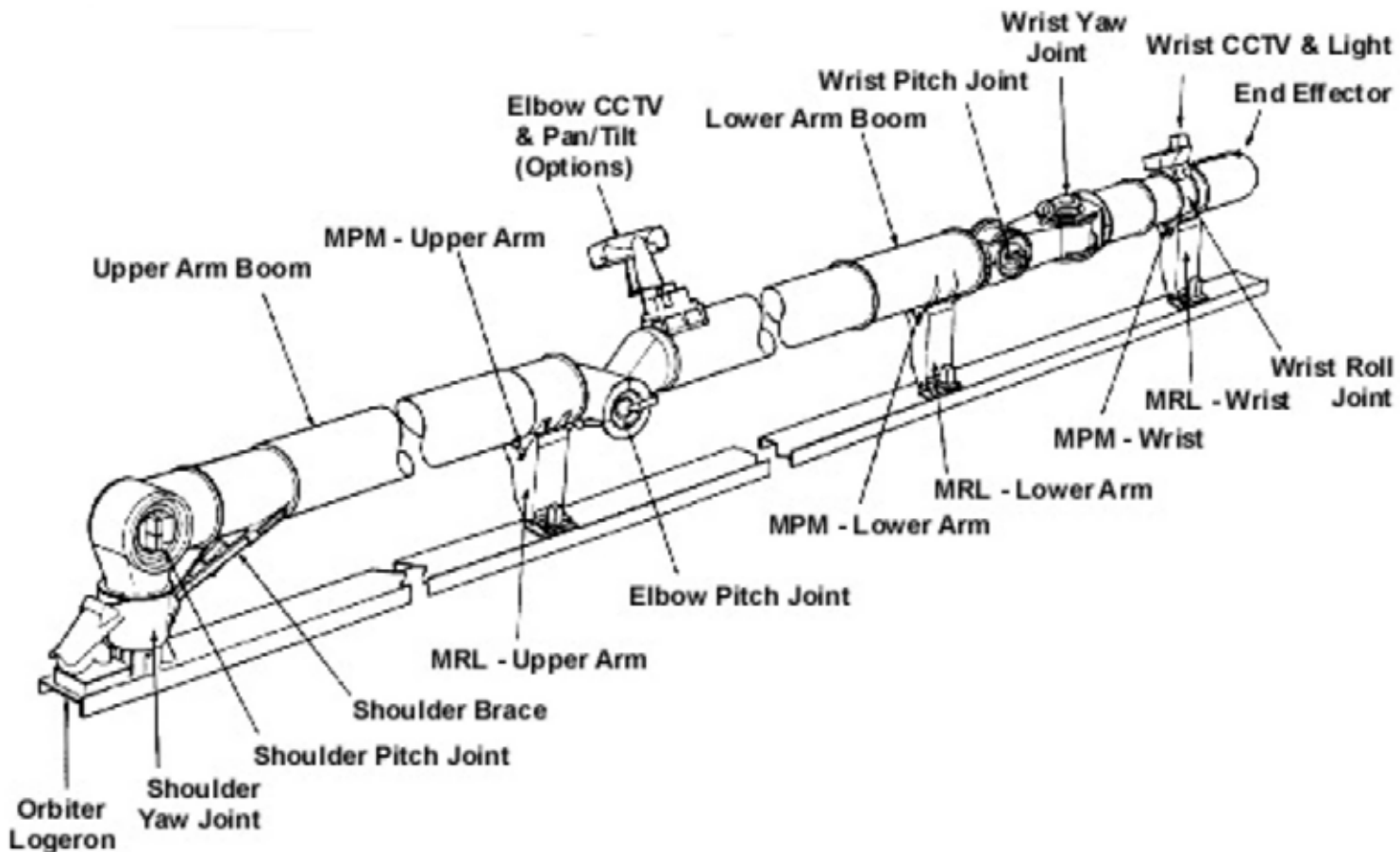

Figure A-3 Canadarm

Note. From Canadian Space Agency, 2006, *The Structure of Canadarm*. Retrieved November 18, 2008, from <http://www.asc-csa.gc.ca/eng/canadarm/description.asp>

## Cartesian Robot

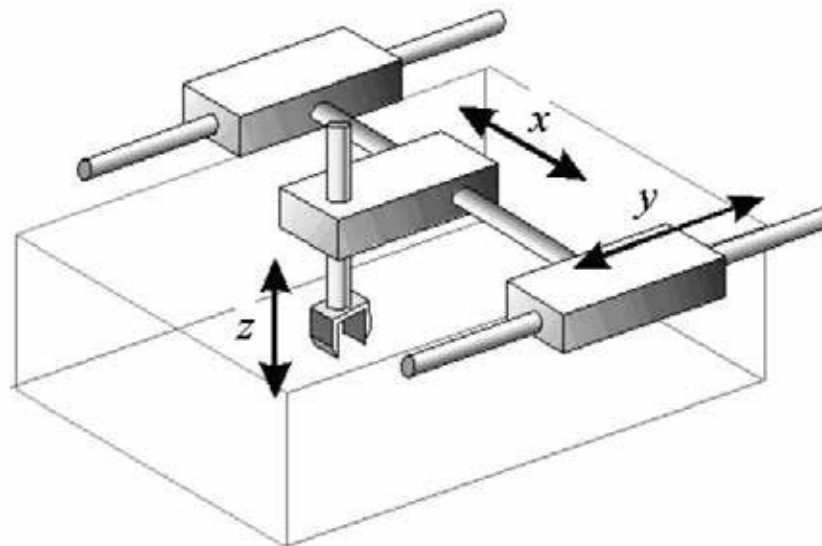

Figure B-1 Cartesian Robot

Note. From "ROVer Ranch K-12 Experiments in Robotic Software" by NASA, 2003, *Types of Robots*. Retrieved November 17, 2008, from <http://prime.jsc.nasa.gov/ROV/types.html>

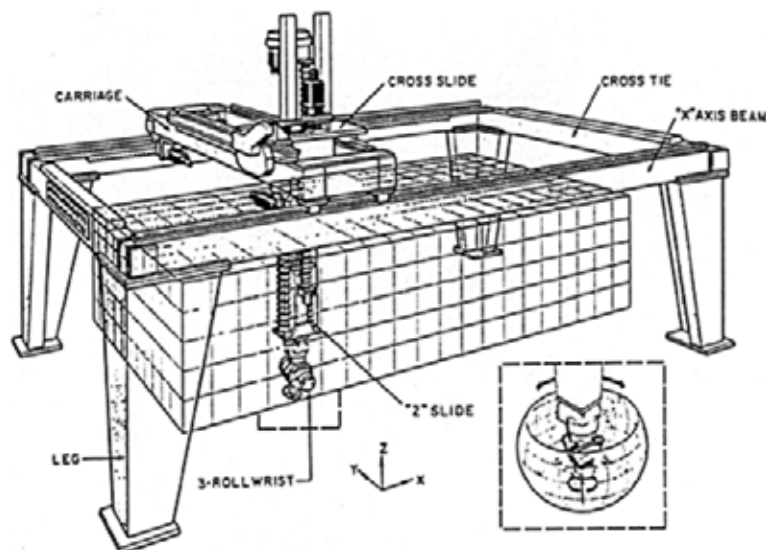

Figure B-2 Cartesian Gantry Robot

Note. From "ROVer Ranch K-12 Experiments in Robotic Software" by NASA, 2003, *Types of Robots*. Retrieved November 17, 2008, from <http://prime.jsc.nasa.gov/ROV/types.html>

# *Cylindrical Robot*

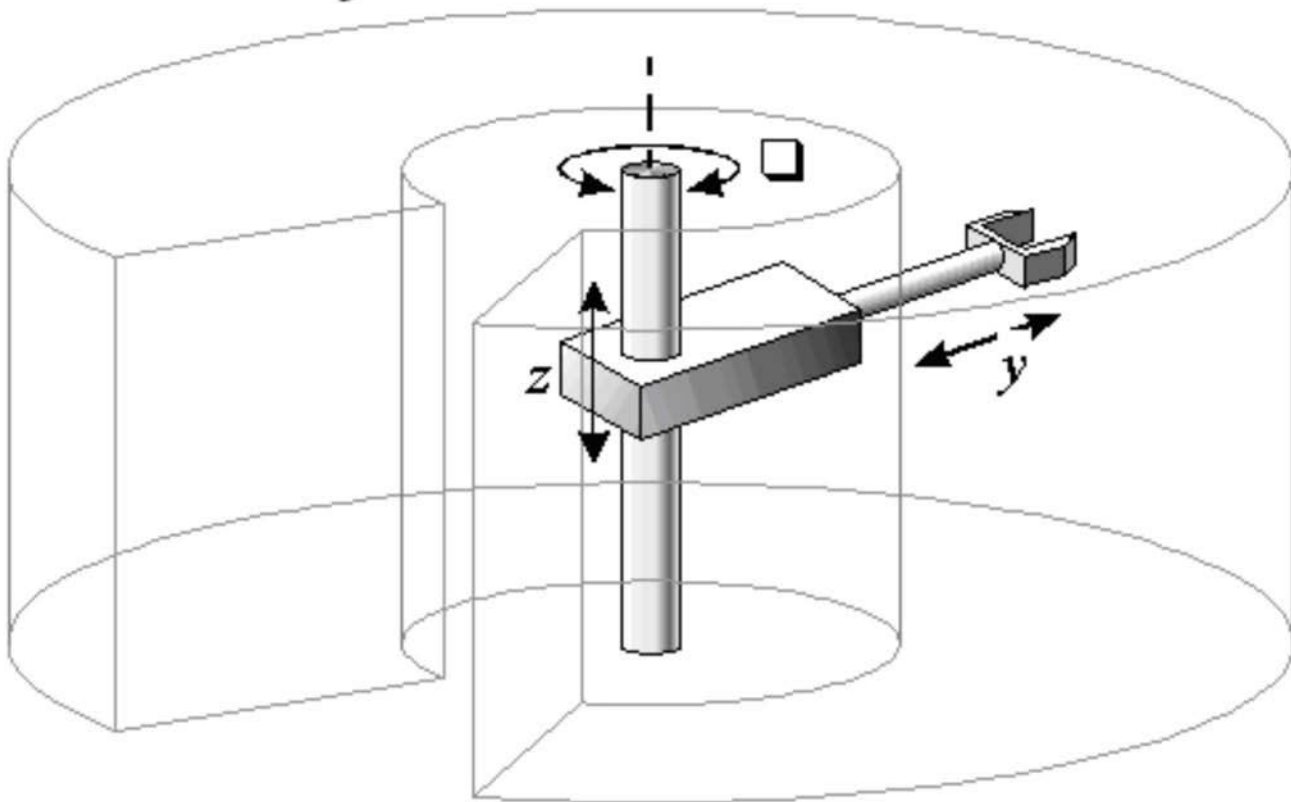

Figure B-3 Cylindrical Robot

*Note.* From "ROVer Ranch K-12 Experiments in Robotic Software" by NASA, 2003, *Types of Robots*. Retrieved November 17, 2008, from <http://prime.jsc.nasa.gov/ROV/types.html>

# *Polar Robot*

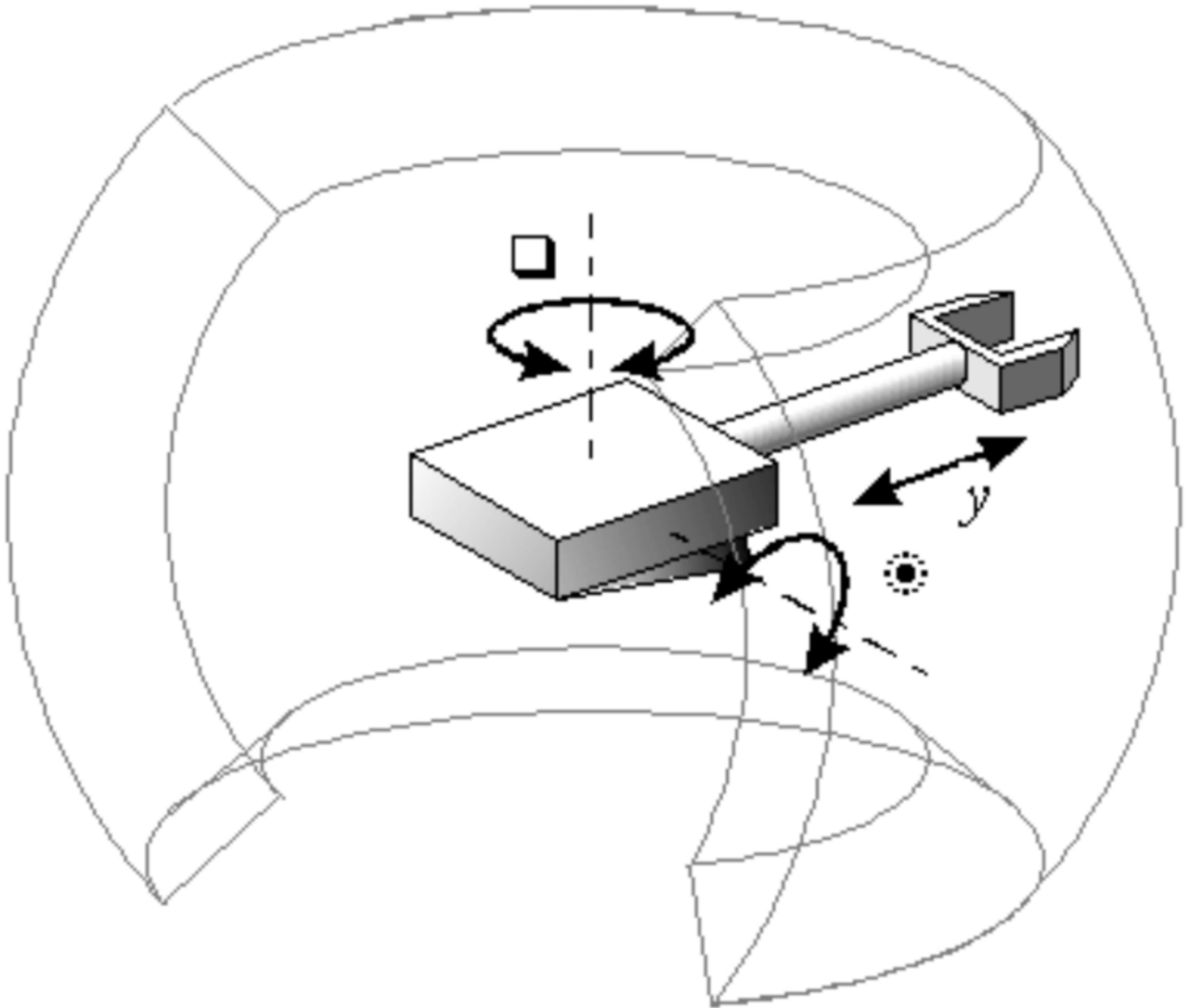

Figure B-4 Polar Robot

*Note.* From "ROVer Ranch K-12 Experiments in Robotic Software" by NASA, 2003, *Types of Robots*. Retrieved November 17, 2008, from <http://prime.jsc.nasa.gov/ROV/types.html>

## *SCARA Robot*

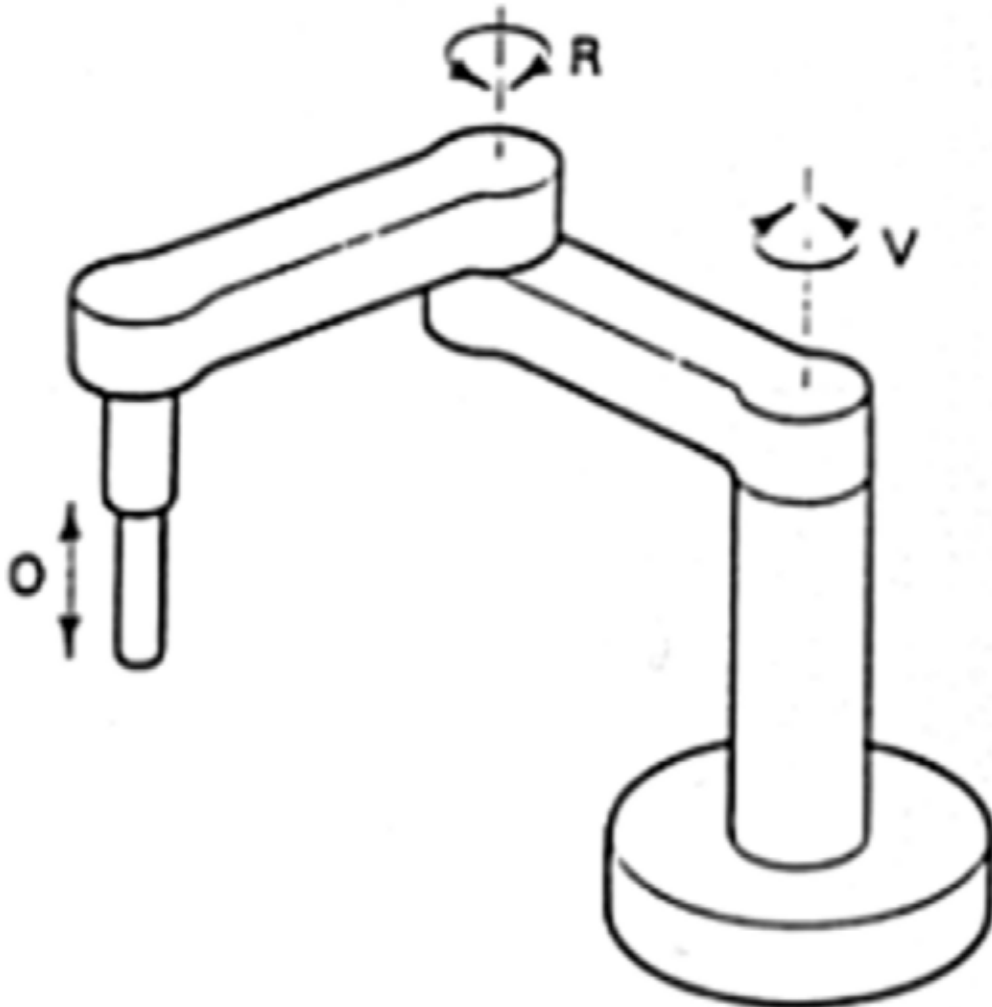

Figure B-5 Selective Compliant Articulated Robot for Assembly (SCARA) Robot

*Note.* From "ROVer Ranch K-12 Experiments in Robotic Software" by NASA, 2003, *Types of Robots*. Retrieved November 17, 2008, from <http://prime.jsc.nasa.gov/ROV/types.html>



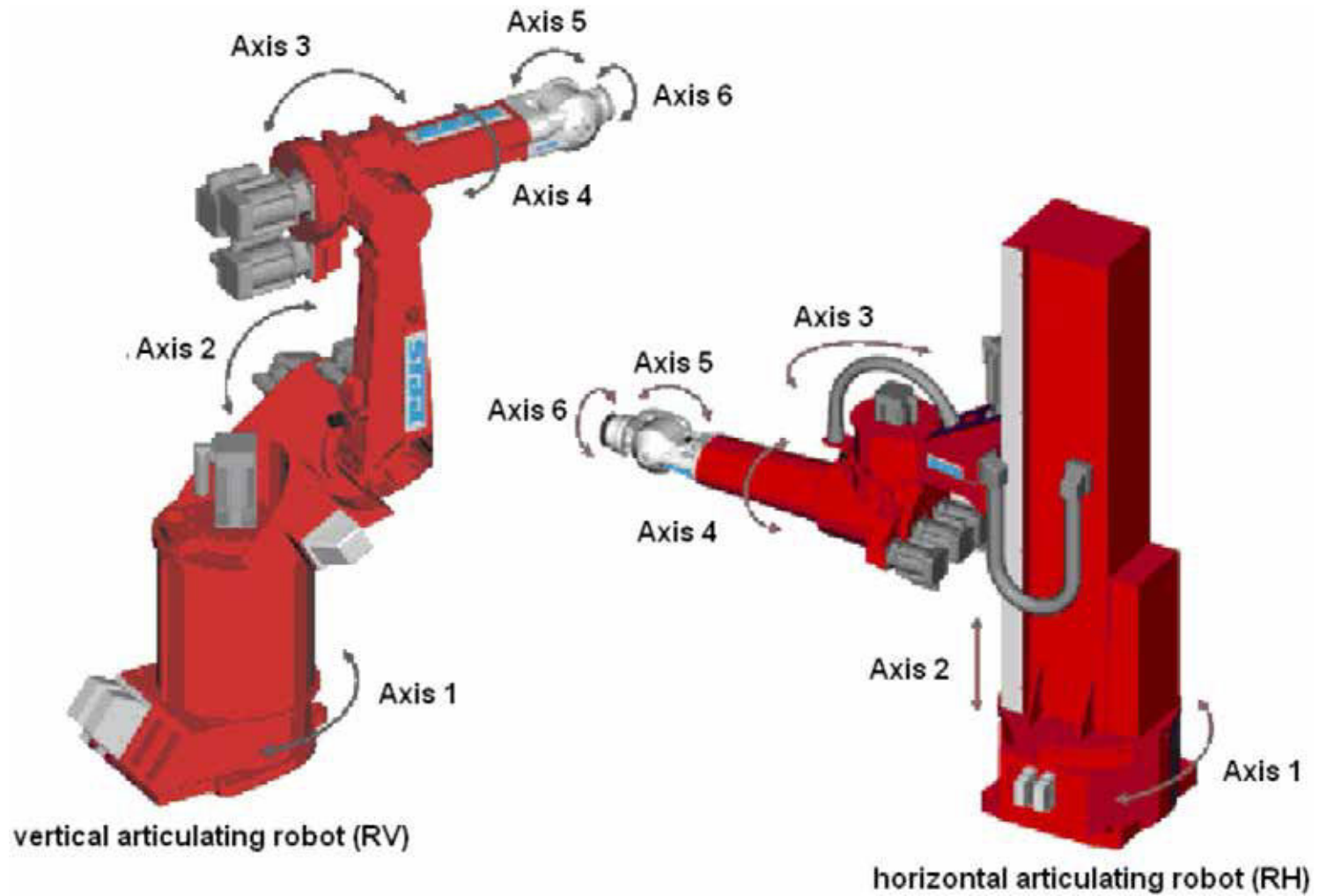

Figure B-6 Articulated Robots

*Note.* From "Robotics & Automation Home: Types of Robots" by Olympus Technologies Ltd., 2008, *Articulating Robots*. Retrieved November 22, 2008, from <http://www.olympustechnologies.co.uk/Robotics/types-articulating.htm>

*Parallel Robot*

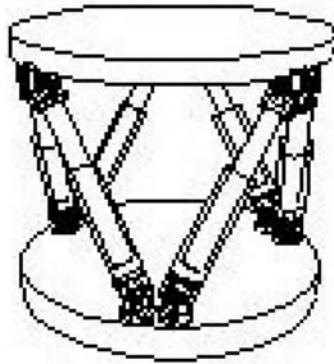

Figure B-7 Parallel Robot

*Note.* From "ROVer Ranch K-12 Experiments in Robotic Software" by NASA, 2003, *Types of Robots*. Retrieved November 17, 2008, from <http://prime.jsc.nasa.gov/ROV/types.html>

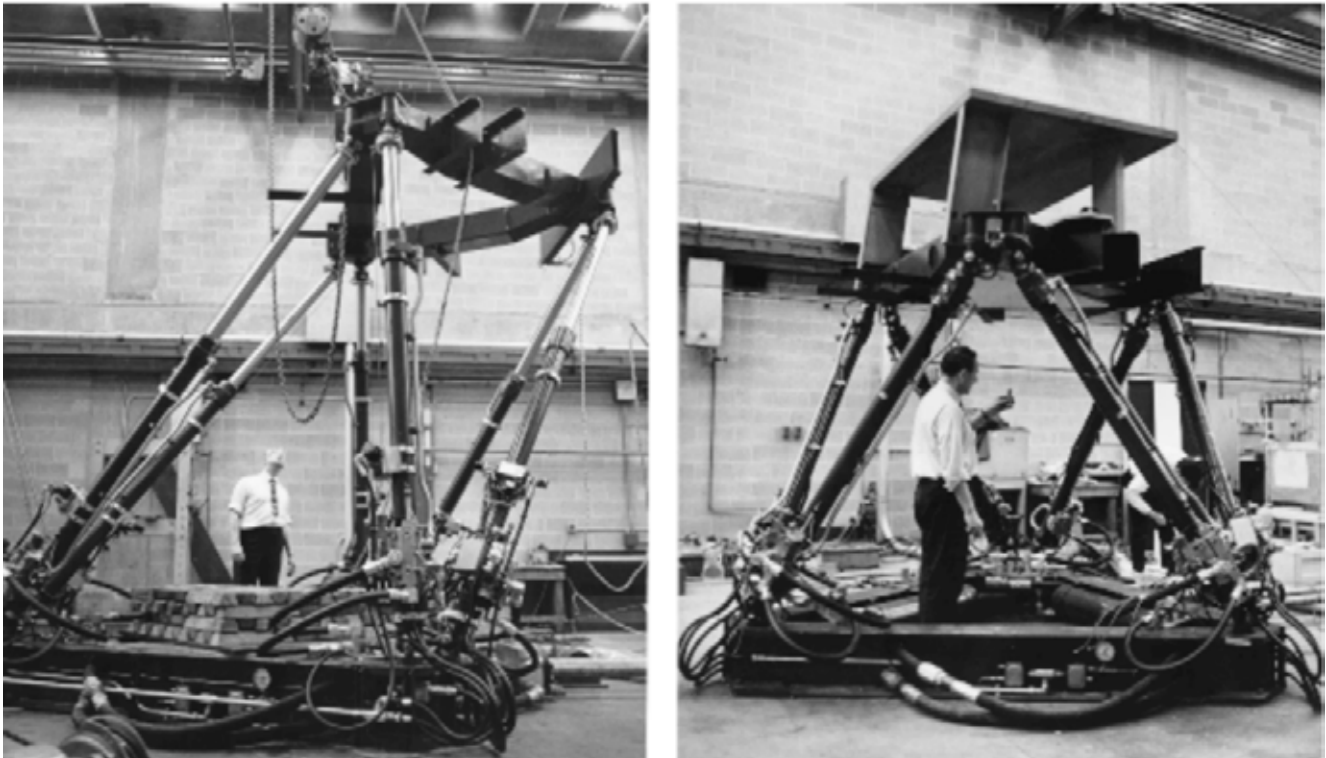

Figure B-8 Parallel Robot: An Early Flight Simulator

*Note.* From "Reviews in the Field of Parallel Mechanisms", by ParalleMIC, 2003, Copyright 2003 by Ilian Bonev, *The True Origins of Parallel Robots*. Retrieved November 22, 2008, from <http://www.olympustechnologies.co.uk/Robotics/types-articulating.htm>



Figure C-1 Seaglider

*Note.* From "Robots That Make a Difference", by iRobot, 2008, *Missions for Maritime Operations: Seaglider*, Copyright 2007, by iRobot. Retrieved November 20, 2008, from <http://www.irobot.com/sp.cfm?pageid=393>

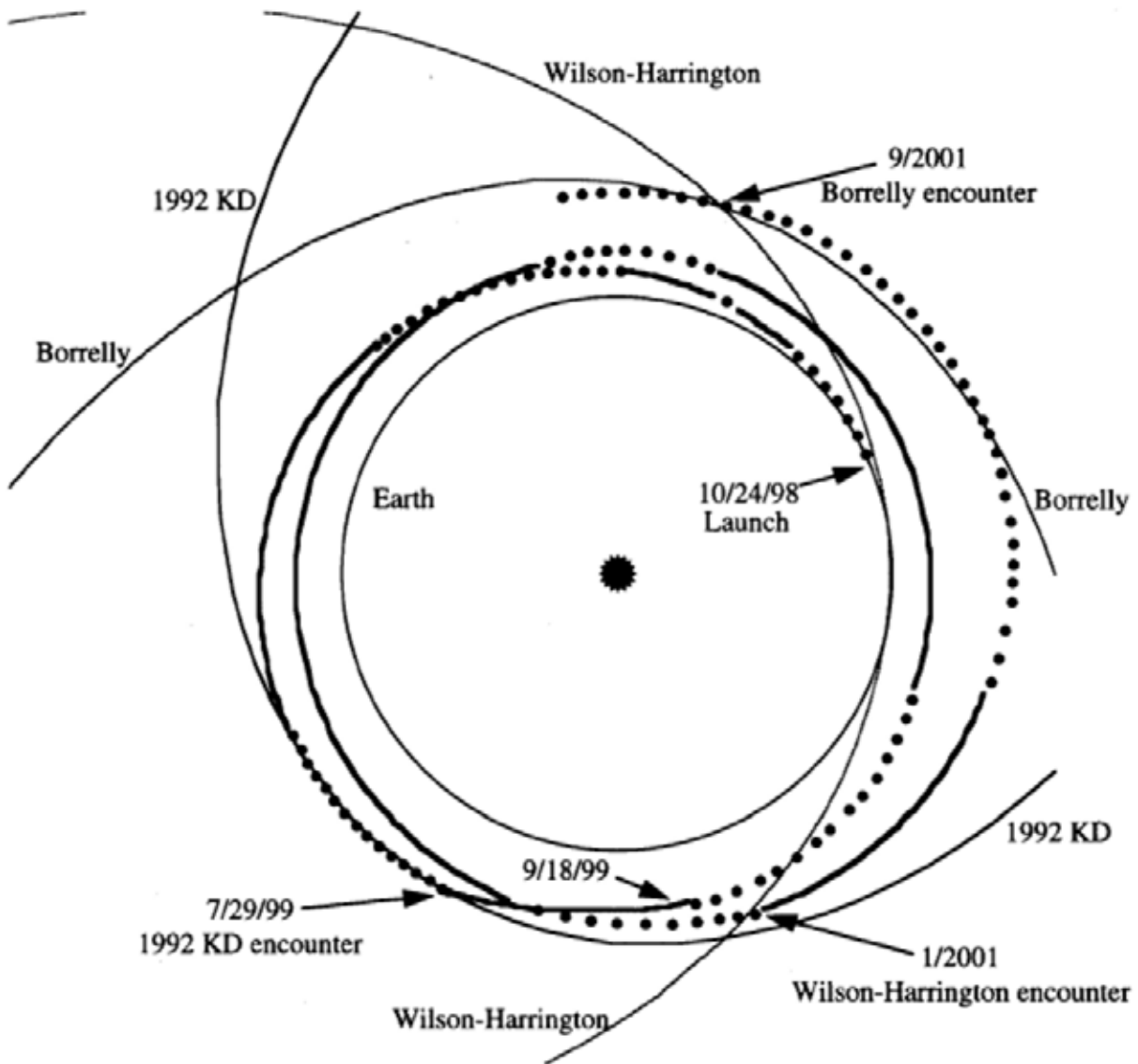

Figure C-2 DS1 Trajectory

*Note.* From *Results From the Deep Space 1 Technology Validation Mission*, by M. Rayman, P. Varghese, D. Lehman, and L. Livesay. Copyright 1999 by the American Institute of Aeronautics and Astronautics, Inc. Retrieved November 20, 2008, from [http://nmp.jpl.nasa.gov/ds1/DS1\\_Primary\\_Mission.pdf](http://nmp.jpl.nasa.gov/ds1/DS1_Primary_Mission.pdf)

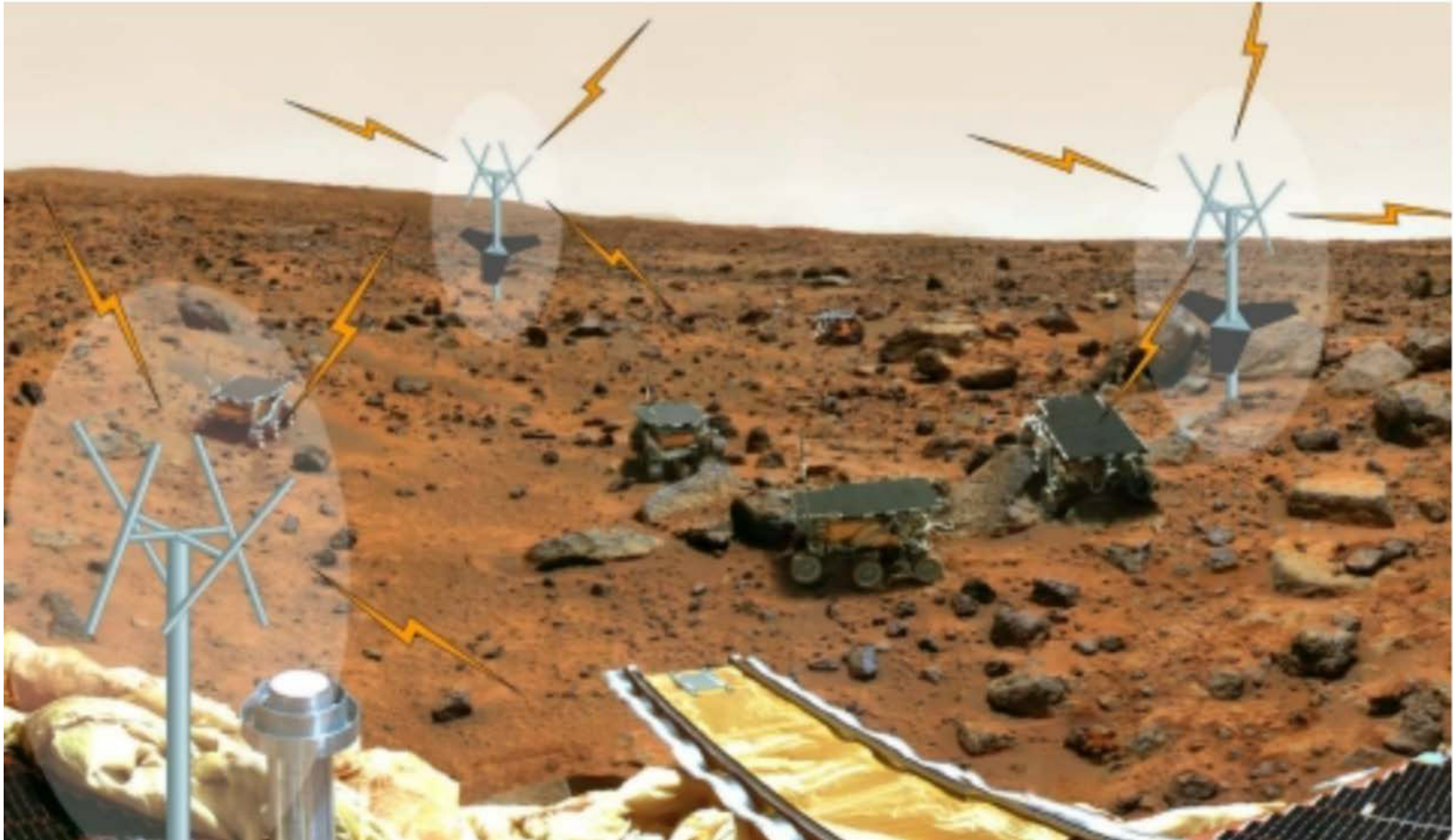

Figure C-3 Self-Calibrating Pseudolite Array

*Note.* From "ARL Projects", by Stanford University Aerospace Robotics Laboratory, 2005, *Mars Rover Navigation Using GPS Self-Calibrating Pseudolite Arrays*. Retrieved November 20, 2008, from <http://arl.stanford.edu/>





Figure C-4 Sniper Detection

Note. From "Robots That Make a Difference", by iRobot, 2008, *Missions for Ground Forces: Sniper Protection*, Copyright 2007 by iRobot. Retrieved November 20, 2008, from <http://www.irobot.com/sp.cfm?pageid=165>



**ROYAL CANADIAN AIR CADETS  
PROFICIENCY LEVEL FOUR  
INSTRUCTIONAL GUIDE**



**SECTION 8**

**EO C440.06 – USE STAR CHARTS**

Total Time:

60 min

**PREPARATION**

**PRE-LESSON INSTRUCTIONS**

Resources needed for the delivery of this lesson are listed in the lesson specification located in A-CR-CCP-804/PG-001, *Proficiency Level Four Qualification Standard and Plan*, Chapter 4. Specific uses for said resources are identified throughout the instructional guide within the TP for which they are required.

Review the lesson content and become familiar with the material prior to delivering the lesson.

Obtain a desktop globe for use in TP 2.

Obtain planisphere star charts and red-filtered flashlights for each cadet for use in TP 4.

Create slides of Attachments A and B.

Photocopy Attachment C for each cadet.

**PRE-LESSON ASSIGNMENT**

Nil.

**APPROACH**

An interactive lecture was chosen for TPs 1–3 to introduce the cadets to star charts and give an overview of the subject.

A demonstration and performance was chosen for TP 4 as it allows the instructor to explain and demonstrate planisphere use while providing an opportunity for the cadets to practice the skill under supervision.

**INTRODUCTION**

**REVIEW**

Nil.

**OBJECTIVES**

By the end of this lesson the cadet shall have used star charts to identify elements of the night sky.

**IMPORTANCE**

It is important for cadets to be able to use star charts because this knowledge enhances the enjoyment of amateur astronomy while contributing to an understanding of the aerospace challenge.

**Teaching Point 1****Explain how the celestial sphere is divided.**

Time: 5 min

Method: Interactive Lecture

**HOW EARTH AND SKY ARE ASSUMED TO BE CONCENTRIC**

**Celestial sphere.** An imaginary sphere with the observer at its centre and celestial objects located on its inner surface.

**Concentric.** Having a common centre.

At first sight, the complexity of the night sky may seem bewildering. Familiarity with the night sky, as well as determining and describing the locations of celestial objects such as stars and galaxies, requires a standardized coordinate system. Such a system allows workers in the field to communicate celestial positions so that the observation can be repeated by others. For this purpose, a standardized coordinate system known as the celestial sphere was created. The celestial sphere is an optical illusion resulting from the inability to discern distance to stars making them all appear to be the same distance away. This imaginary sphere, therefore, is of infinite radius with the Earth located at its centre. The poles of the celestial sphere are aligned with the poles of the Earth. The celestial equator lies along the celestial sphere in the same plane that includes the Earth's equator. This is designed for the convenience of observers on Earth. The optical illusion of the celestial sphere can only be seen, in its orientation showing the classic constellations, from within the solar system.



Show the cadets the slide of Figure A-1 located at Attachment A.

When considering the celestial sphere it is convenient to assume that the sky is solid and that the celestial sphere is concentric with, or has the same centre as, the surface of the Earth.

**CELESTIAL POLES**

The north pole of the celestial sphere is the point directly above the Earth's north pole and the south pole of the celestial sphere is the point directly below the Earth's south pole. The North Celestial Pole (NCP) and the South Celestial Pole (SCP) are simply the north and south poles of the Earth extended into space.



Show the cadets the slide of Figure A-2 located at Attachment A.

The NCP passes very close to the star Polaris. As the Earth rotates around the NCP, Polaris is the only object in the sky that appears to stand still.

**CELESTIAL EQUATOR**

The celestial equator is the Earth's equator, but at a much greater radius. If the Earth's equator was a rubber band, then the celestial equator is the same rubber band just stretched away from the Earth, out to infinity.



**CONFIRMATION OF TEACHING POINT 1****QUESTIONS:**

- Q1. What is the celestial sphere?
- Q2. What are the NCP and the SCP?
- Q3. Where is the celestial equator located?

**ANTICIPATED ANSWERS:**

- A1. The celestial sphere is an imaginary sphere of infinite radius with the Earth located at its centre.
- A2. The North Celestial Pole (NCP) and the South Celestial Pole (SCP) are simply the north and south poles of the Earth extended into space.
- A3. The celestial equator lies along the celestial sphere in the same plane of the Earth's equator.

**Teaching Point 2****Explain how the sphere of the sky is represented on star charts.**

Time: 5 min

Method: Interactive Lecture

We can locate any object on the celestial sphere by giving it two coordinates, one called the object's declination and the other the object's right ascension. These are the object's celestial coordinates.



Show the cadets the slide of Figure A-1 located at Attachment A.

**DECLINATION**

The structure of the celestial coordinate lines is almost identical to that of the coordinates of the Earth's surface. To prevent confusion, the Earth's lines of latitude are re-labelled as "declination" lines when applied to the celestial sphere, but are numbered in degrees exactly the same as the Earth lines of latitude. However, to further avoid confusion, the celestial lines of declination are marked with a plus sign (+) in place of North and a minus sign (-) in place of South. Therefore, when a declination is shown as a negative number it is in the southern half of the celestial sphere.



Parts of the southern celestial sphere can be seen from Earth's northern hemisphere, especially during the northern hemisphere's winter months. The brightest star in the sky, Sirius, at minus 20 degrees, can be seen from Canada in the winter because, just as the northern hemisphere is inclined toward the North in the daytime, it is inclined toward the South in the nighttime.



Use a globe to show the cadets how the northern hemisphere in winter changes from northern daytime skies to southern nighttime skies as night falls.

## RIGHT ASCENSION

To further prevent confusion, the longitude lines have been re-labelled as "right ascension" lines, and renumbered from 0 to 24 in hours. There is only an indirect connection to time here, even though hours, minutes and seconds are used to divide the angular distances between lines of right ascension. However, the celestial sphere, observed from the surface of Earth, is seen to complete one complete rotation overhead approximately once every 24 hours. Celestial rotation would be 24 hours exactly, if it were not for Earth's orbit around the Sun.

The right ascension of an object on the celestial sphere is measured along the celestial equator. By convention, 0 degrees is the point on the celestial equator where the Sun is found on the first day of spring (the vernal equinox).



Notice that 0 hours right ascension is unrelated to 0 degrees longitude. Using hours instead of degrees neatly avoids this conflict.

Stars and galaxies have (almost) fixed positions in right ascension and declination. The Sun and planets, on the other hand, move among the distant stars so that their coordinates change throughout the year. Due to the Earth's yearly orbital motion around the Sun, the Sun appears to circle the ecliptic.

## THE PLANE OF THE ECLIPTIC

**Plane of the ecliptic.** The plane of the Earth's orbit around the Sun.

The plane of the ecliptic is an imaginary plane in which the Earth orbits the Sun. It is used as the primary reference plane when describing the position of bodies in the solar system.



Show the cadets the slide of Figure B-1 located at Attachment B.

Most objects in the solar system orbit in roughly this plane and in the same direction around the Sun as the Earth. There are exceptions such as many comets and a few minor planets (including the dwarf planet, Pluto), which have high inclinations, or tilt, compared to the reference plane—the plane of the ecliptic. Some comets even have retrograde orbits, such as Halley's comet, and orbit in the opposite direction to the planets.



Show the cadets the slide of Figure B-2 located at Attachment B.

The celestial sphere, viewed from Earth, shows the constellations that define the zodiac. The signs of the zodiac are the constellations that lie near the plane of the ecliptic and are visible at night in the months associated with these constellations.



Ask the cadets what the approximate date is in Figure B-2 located at Attachment B.

---

## CONFIRMATION OF TEACHING POINT 2

### QUESTIONS:

- Q1. What are a celestial object's two coordinates called?
- Q2. On what is a celestial object's right ascension measured?
- Q3. What is the plane of the ecliptic?

### ANTICIPATED ANSWERS:

- A1. Right ascension and declination.
- A2. The celestial equator.
- A3. The plane of the Earth's orbit around the Sun.

---

## Teaching Point 3

**Explain how to interpret a star chart.**

Time: 5 min

Method: Interactive Lecture

---

A star chart is a map of the night sky. With it, you can identify and locate constellations and stars. A typical star chart shows the relative positions of the stars and their brightness.

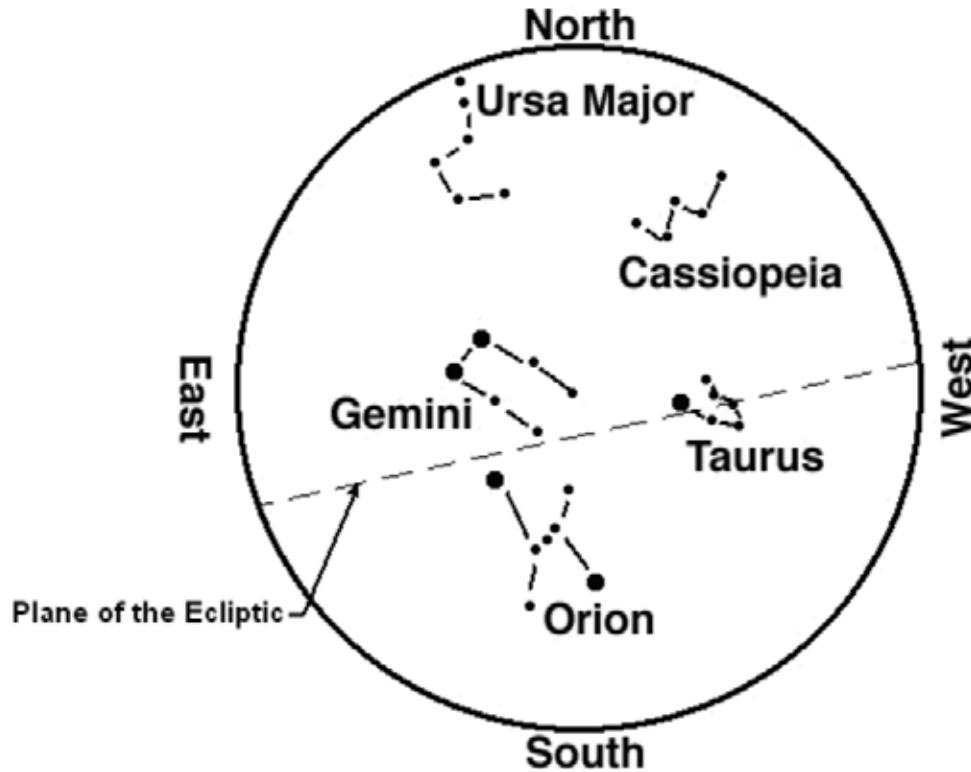

Figure 1 A Northern Hemisphere Spring Star Chart

*Note.* From "Astronomy Department at the University of Massachusetts", by T. Arny, 2002, *Using a Star Chart*, Copyright 2002, by T. Arny. Retrieved November 4, 2008, from [http://www.astro.umass.edu/~arny/constel/constel\\_tutmod.html](http://www.astro.umass.edu/~arny/constel/constel_tutmod.html)

## DATE

A star chart is accurate only on a specific date because the night sky changes as Earth follows its orbit around the Sun. Also, planets move over a period of days.

## TIME

A star chart will be correct for a very short time because celestial objects rise above the eastern horizon and follow a path overhead before finally setting in the West. Since different celestial objects are constantly rising and passing overhead and setting, a different set of celestial objects will occupy the sky at different times. The date and time of exact accuracy should be printed on the chart.

## LATITUDE

An observer on the ground can only see the sky above the horizon. Different locations on the planet have different views of the sky. Although a patient observer can wait for a certain celestial object to rise in the East, and a celestial object with a certain right ascension will eventually appear if it is at an observable declination, there are celestial objects that are not in an observable declination for a given Earth latitude. For example, Polaris, the North Star, will never be seen from the Earth's South Pole. Therefore, a star chart has a property known as latitude and it will only show the sky that can be seen at the Earth latitude for which the star chart was prepared. The star chart's Earth latitude is printed on the star chart.

## ORIENTATION

For orientation, a star chart is held overhead and turned until the direction the observer is facing appears at the bottom. If the observer is facing south, the star chart, when held overhead, should be turned until South is on

the bottom of the star chart. At this point, the pattern of celestial objects shown on the star chart will correspond to the pattern of celestial objects seen in the sky.

## PLANETS

Planets add another layer of challenge to interpreting a star chart. Planets constantly change their position relative to fixed celestial objects.



Star charts can be retrieved from the Montreal Planetarium website:  
<http://www.planetarium.montreal.qc.ca/Information/Documents/PDF/PocketPlanetariumV12N4.pdf> and other websites, such as <http://skymaps.com/downloads.html>

---

## CONFIRMATION OF TEACHING POINT 3

### QUESTIONS:

- Q1. What are two reasons that a star chart is accurate only on a specific date?
- Q2. Why is a star chart accurate only at a specific hour?
- Q3. For orientation, how is a star chart held?

### ANTICIPATED ANSWERS:

- A1. The night sky changes as Earth follows its orbit around the Sun and planets constantly move.
- A2. The night sky changes as Earth rotates on its axis.
- A3. For orientation, a star chart is held overhead and turned until the direction the observer is facing appears at the bottom.

---

## Teaching Point 4

**Explain, demonstrate and have the cadets identify elements of the night sky by exploring aspects of a planisphere.**

Time: 40 min

Method: Demonstration and Performance

**Planisphere star chart.** Analog computer for calculating the position of stars.



Distribute a planisphere star chart to each cadet.

A planisphere consists of two layers: a star map base and an overlay in which is set a clear oval window. The four steps to orienting a planisphere are as follows:

1. Locate the date, on the star map layer, on which the planisphere is to be used.
2. Rotate the overlay so that the time of use aligns with the date of use.
3. Identify North by locating the North Star.
4. The planisphere is then held above the user's head, map downward, with the middle of the oval window directly overhead and the midnight time mark toward the North.

The coordinates of a celestial object shown on a planisphere can be determined by reading the hours of right ascension from the outer edge of the star map base. Lines of right ascension run from the edge of the star map base to the centre of the star map base. A celestial object's declination can be determined by interpolating between the concentric declination lines which circle the star map base, with the celestial equator shown at 0 degrees—passing through constellation Orion at 6 hours right ascension.



Instruct the cadets on how to use the specific planisphere star chart according to directions provided with the planisphere.

Planispheres generally have the following characteristics:

- a. **Planisphere design.** A planisphere has this name because the celestial sphere is represented on a flat plane, such as paper. Since the Earth is constantly in motion, the time of day, time of year, and location influence the appearance of the sky. An individual star chart cannot accurately represent all of these combinations. This would take many different star charts. A preferable method is to use a planisphere star chart that allows the user to twist a dial to show the true position of the stars.
- b. **The lack of planetary data on a planisphere.** Since the planisphere is usable on any day, it cannot display planets because planets constantly move across the sky.
- c. **Date.** The visible night time stars and constellations change as the Earth revolves around the Sun. The summer sky is therefore different than the winter sky because the Earth is facing the opposite direction. Therefore, the correct date must be selected on the planisphere.
- d. **Time.** As the Earth turns on its axis, stars and constellations rise in the East and set in the West, just as the Sun does (the Sun is just one more star, but a close one). Therefore, the planisphere must be adjusted for correct time.
- e. **Midnight time mark.** When applying the planisphere to the night sky, the planisphere is oriented so that the midnight mark is to the North, after the time of day on the overlay is aligned with the date on the star map base.
- f. **Latitude.** Planispheres are specific to latitudes because each latitude allows a view of a different swath of the celestial sphere as the Earth rotates.
- g. **Orientation.** For constellations to appear in their correct location on the planisphere at the correct time, it is necessary to align the planisphere correctly with True North. When that is done, constellations that are rising in the East will be shown on the east edge of the planisphere. The planisphere consists of two layers: a star map base and an overlay in which is set a clear oval window.
- h. **Horizon.** The edges of the clear overlay window represent the viewer's approximate horizon.
- i. **Constellations.** On most planispheres, the names of constellations are printed in capital letters.
- j. **Stars.** On most planispheres, the names of stars are printed in lower case letters, except the first letter in the star's name, which is capitalized.

---

## ACTIVITY

Time: 30 min

### OBJECTIVE

The objective of this activity is to have the cadets identify elements of the night sky by exploring aspects of a planisphere.

### RESOURCES

- Observation Record located at Attachment C,
- Planispheres, and
- Red-filtered flashlights.

### ACTIVITY LAYOUT

- For the demonstration portion of this lesson, organize the cadets into a circle with the instructor as a member of the circle.
- For the performance portion of this lesson, the cadets keep within hearing distance of the instructor so the instructor can easily respond to questions.

### ACTIVITY INSTRUCTIONS

1. Distribute a photocopy of Attachment C to each cadet.
2. Distribute one red-filtered flashlight per four cadets and have the cadets orient their planispheres.
3. Have the cadets locate celestial objects and constellations, using a planisphere.
4. Have the cadets determine the coordinates of celestial objects by reading declination and right ascension from the star base map of the planisphere, including interpolation between the coordinate lines.
5. Have the cadets record their observations of the celestial sphere on Attachment C.

### SAFETY

Nil.

---

### CONFIRMATION OF TEACHING POINT 4

The cadets' participation in identifying elements of the night sky by exploring aspects of a planisphere will serve as the confirmation of this TP.

---

### END OF LESSON CONFIRMATION

### QUESTIONS

- Q1. What is the celestial sphere?
- Q2. Why are planispheres specific to latitudes on Earth?
- Q3. Where does the name planisphere come from?

### **ANTICIPATED ANSWERS**

- A1. The celestial sphere is an imaginary sphere of infinite radius with the Earth located at its centre.
- A2. Planispheres are specific to latitudes on Earth because each latitude allows a view of a different swath of the celestial sphere as the Earth rotates.
- A3. A planisphere has this name because the celestial sphere is represented on a flat plane, such as paper.

---

### **CONCLUSION**

---

### **HOMEWORK / READING / PRACTICE**

Nil.

### **METHOD OF EVALUATION**

Nil.

### **CLOSING STATEMENT**

Knowledge of how to use a star chart is very helpful in amateur astronomy and will aid in the identification of many celestial bodies that would otherwise be missed.

### **INSTRUCTOR NOTES / REMARKS**

TPs 1–3 may be taught in the classroom or in the field, as appropriate.

Cadets who are qualified Advanced Aerospace may assist with this instruction.

---

### **REFERENCES**

---

C3-176 ISBN 1-55407-071-6 Moore, P. (2005). *Atlas of the universe*. Richmond Hill: Firefly Books.

C3-179 ISBN 1-55209-302-6 Dickenson, T. (2001). *Night watch: A practical guide to viewing the universe*. Willowdale, ON: Firefly Books.

C3-180 ISBN 1-55297-853-2 Scagell, R. (2004). *Firefly planisphere: Latitude 42 deg N*. Willowdale, ON: Firefly Books.

C3-221 National Research Council of Canada. (2007). *Explore the night sky*. Retrieved December 3, 2007, from <http://www.nrc-cnrc.gc.ca/eng/education/astronomy/constellations/html.html>



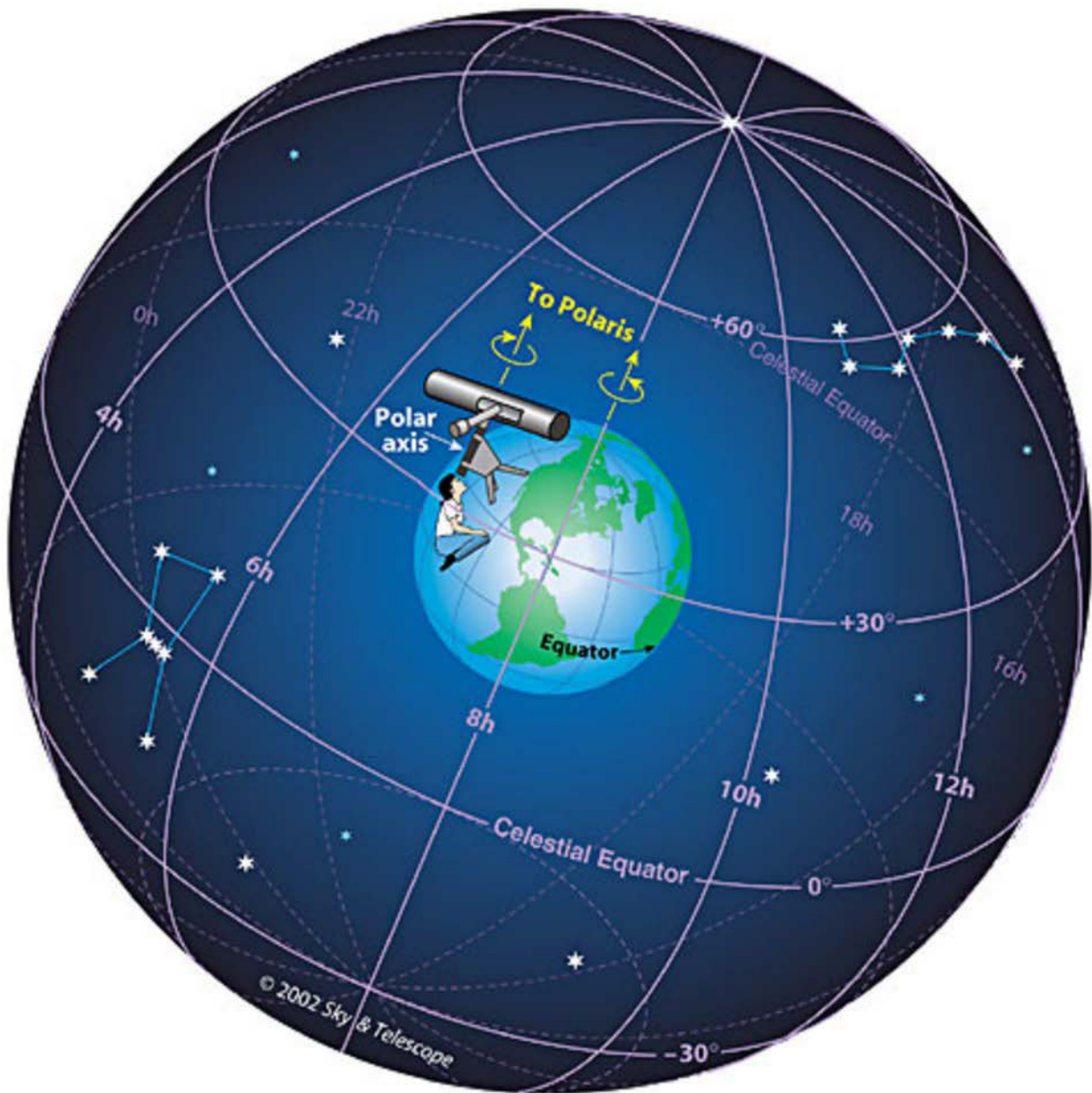

Figure A-1 Aligning With Polaris

Note. From "Sky and Telescope" by A. M. MacRobert, 2001, *Understanding Celestial Coordinates*. Retrieved October 30, 2008, from [http://www.skyandtelescope.com/howto/basics/Celestial\\_Coordinates.htm](http://www.skyandtelescope.com/howto/basics/Celestial_Coordinates.htm)



Figure A-2 Observing Polaris

*Note.* From "Sky and Telescope" by A. M. MacRobert, 2001, *Understanding Celestial Coordinates*.  
Retrieved October 30, 2008, from [http://www.skyandtelescope.com/howto/basics/Celestial\\_Coordinates.html](http://www.skyandtelescope.com/howto/basics/Celestial_Coordinates.html)

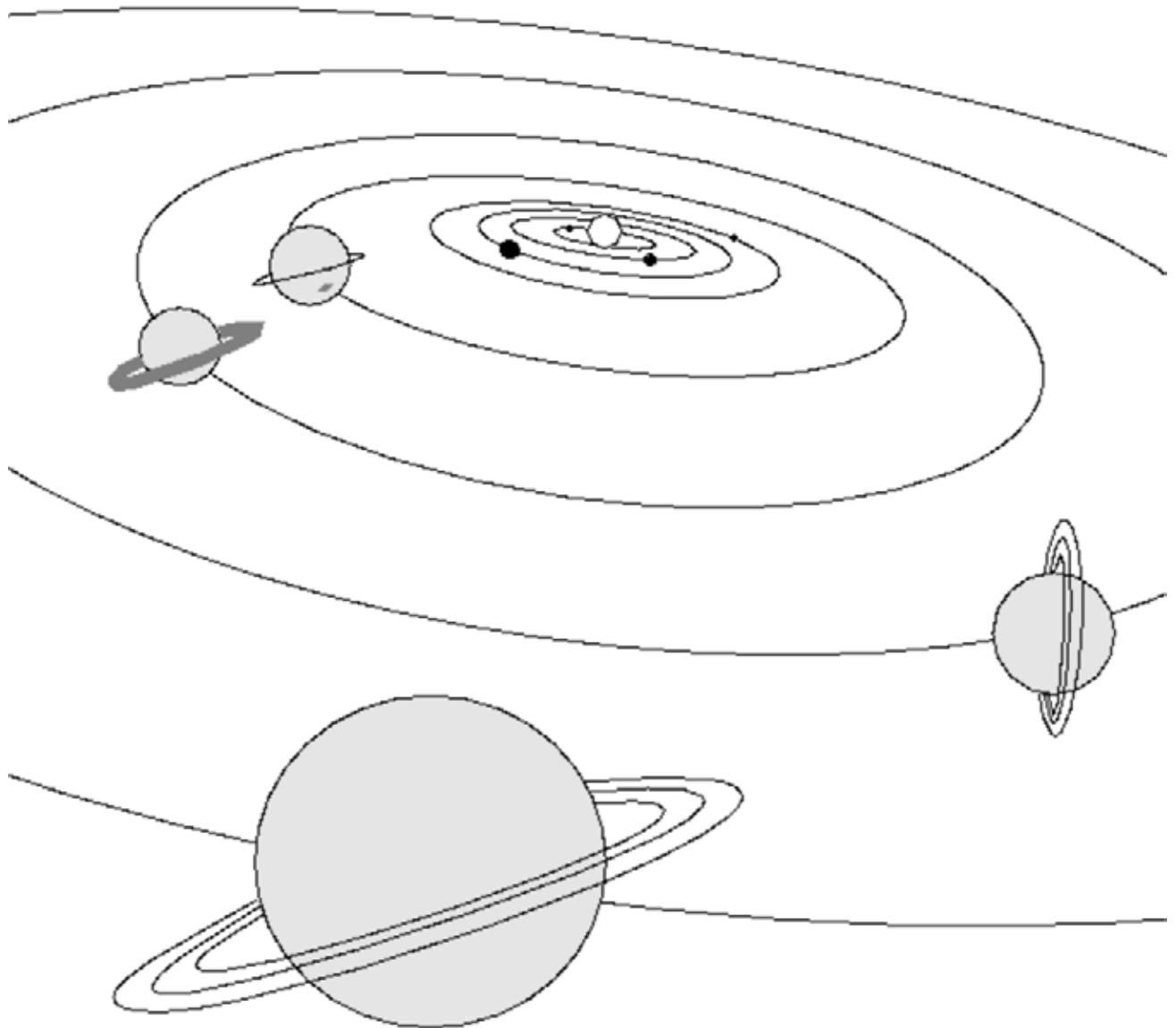

Figure B-1 Third Rock from the Sun

*Note.* From "CSE@SSL", by B. Napier, 1995, *Demonstration: The Plane of the Ecliptic*, Copyright 1995 by Regents of the University of California. Retrieved October 30, 2008, from <http://cse.ssl.berkeley.edu/img/eclip.gif>

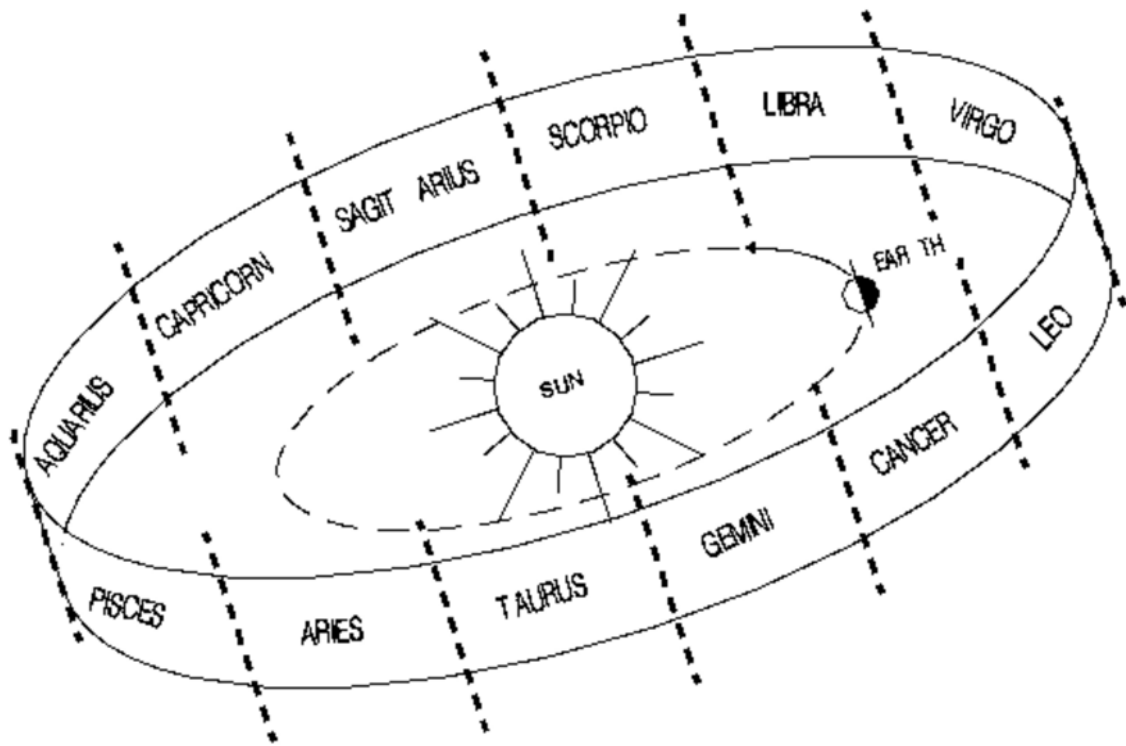

Figure B-2 The Zodiac and its Constellations

Note. From "CSE@SSL", by B. Napier, 1995, *Demonstration: The Plane of the Ecliptic*, Copyright 1995 by Regents of the University of California. Retrieved October 30, 2008, from [http://cse.ssl.berkeley.edu/lessons/indiv/beth/beth\\_intro.html](http://cse.ssl.berkeley.edu/lessons/indiv/beth/beth_intro.html)

Observation Record	
Date:	Time:
Place:	Instruments used:
Conditions:	
Observations:	

THIS PAGE INTENTIONALLY LEFT BLANK



**ROYAL CANADIAN AIR CADETS  
PROFICIENCY LEVEL FOUR  
INSTRUCTIONAL GUIDE**



**SECTION 9**

**EO C440.07 – OPERATE A TELESCOPE**

---

Total Time:	60 min
-------------	--------

---

**PREPARATION**

---

**PRE-LESSON INSTRUCTIONS**

Resources needed for the delivery of this lesson are listed in the lesson specification located in A-CR-CCP-804/PG-001, *Proficiency Level Four Qualification Standard and Plan*, Chapter 4. Specific uses for said resources are identified throughout the instructional guide within the TP for which they are required.

Review the lesson content and become familiar with the material prior to delivering the lesson.

Create slides of figures located at Attachments A and B.

Check that all equipment for TP 3 is serviceable prior to delivering the lesson.

Check the telescope's owner's manual for use procedures and modify the lesson as required.

**PRE-LESSON ASSIGNMENT**

Nil.

**APPROACH**

An interactive lecture was chosen for TPs 1 and 2 to orient the cadets to telescope theory and generate interest in the subject.

A demonstration and performance was chosen for TP 3 as it allows the instructor to explain and demonstrate the telescope-handling skills the cadets are expected to acquire while providing an opportunity for the cadets to practice the skill under supervision.

---

**INTRODUCTION**

---

**REVIEW**

Nil.

**OBJECTIVES**

By the end of this lesson the cadet shall be expected to operate manual and computerized telescopes.

**IMPORTANCE**

It is important for cadets to know how to operate telescopes because this provides a fascinating way to become personally involved with astronomy—an important aspect of aerospace development.

---

**Teaching Point 1****Identify the parts of a telescope.**

Time: 10 min

Method: Interactive Lecture

---



Show the cadets Attachment A and use a telescope as an example, to show where the parts of a telescope are located.

Many telescopes have the following parts and accessories:

**Optical tube.** Forms the body of the telescope.

**Optical tube mounts.** These include:

- equatorial mount (one axis of movement on the Earth's equatorial plane), and
- altazimuth mount (two axes of movement—altitude and azimuth).

**Finderscope.** Used to orient the main telescope.

**Eyepiece.** Used to focus the gathered star light for the human eye.

**Lens cover.** Used to protect the telescope optics when stored.

**Mirrors.** Used to reflect and concentrate light.

**Lens(es).** Used to refract (or change the path of) light.

**Focus knob.** Used to focus the light in the telescope.

**Tripod.** Used to provide a firm, steady base for the telescope.

**Specialty computerized telescope parts.** These include:

- control panel,
- on / off switch,
- computer interface port, and
- power cord.

---

**CONFIRMATION OF TEACHING POINT 1****QUESTIONS:**

- Q1. How many axes of movement does an equatorial mount have?
- Q2. What is the purpose of a finderscope?
- Q3. What is the purpose of a lens?



**ANTICIPATED ANSWERS:**

- A1. One axis of movement.
- A2. A finderscope is used to orient the main telescope.
- A3. A lens is used to refract (or change the path of) light.

**Teaching Point 2****Describe telescope theory.**

Time: 10 min

Method: Interactive Lecture

**SAFETY**

An observer must never look at the sun through an unfiltered lens because the focused sunlight will seriously damage a human eye.

Telescopes are fragile equipment requiring careful handling. Rough handling will not only damage the telescope, but may break the glass.

**WHAT THE NUMBERS REPRESENT****Light Gathering of Main Lens or Mirror (Aperture)**

The main lens or mirror of a telescope is referred to as the telescope's objective. The size of a telescope's objective determines the telescope's aperture. The larger the aperture of a telescope, the more light it can gather in a given unit of time. This not only makes certain features more visible to the human eye, it also shortens exposure times for celestial photography. A 30-cm (12-inch) main mirror produces images nine times brighter than a 10-cm (4-inch) mirror. Large telescopes are more difficult to move and handle, but smaller telescopes require longer exposure times for celestial photography.

**Focal Length**

Focal length is the distance that the main lens or mirror of a telescope takes to focus light to the point of focus. The longer the focal length, the larger the image at the focal point. This can be made up on a short focal length telescope, in most cases, by the magnification of the eyepiece. Although a long focal-length telescope produces a larger image at focus, it will also be fainter because the long focal path spreads out the light. During photography, when no eyepiece is used, a longer focal length is sometimes an advantage because it yields a larger image with comparable magnification.



The magnifying power of a telescope can be changed by changing the eyepiece (also referred to as the ocular). To determine the magnification of a telescope, divide the focal length of the telescope by the focal length of the eyepiece being used.

**Focal Ratio**

Focal ratio is the ratio of a telescope's focal length to the diameter of its main lens or mirror—its objective. Focal ratio is found by dividing focal length by objective diameter (aperture). A telescope with a mirror of 20 cm (8 inches) across and a focal length of 122 cm (48 inches) has a focal ratio of  $f/6$ . A telescope's focal length can be found by multiplying focal ratio by aperture, so that a telescope with a 20-cm (8-inch) aperture and  $f/6$  ratio would have a focal length of 122 cm (48 inches).

Long focal lengths are considered to be in the  $f/9$  or greater range. A telescope of a given diameter coupled with a short focal length produces bright images but wide fields. This is fine for observing large deep-sky objects and

star fields, but to photograph planets and binary stars, a longer focal length is superior because the planet's or binary's image is larger at the point of focus.

## **SEEING**

Seeing refers to the steadiness of the image of a celestial object viewed through the telescope. Good seeing means a steady image, while bad seeing means an unsteady image. Binoculars, which typically have much less magnification, can tolerate greater shaking movement without degraded seeing. It is the image, which is viewed, that determines seeing.

### **Image Shaking**

Any movement of the telescope while viewing will degrade seeing. Heavier tripods tend to provide a steadier base for a telescope and improve seeing. Spindly tripods tend to degrade seeing by allowing the telescope to shake during use.

### **Shimmering (Atmospheric Turbulence)**

Turbulence in the Earth's atmosphere imparts a shimmering quality to telescope images. This is the same effect which makes stars appear to twinkle to the naked eye. The intensity of the turbulence depends on winds, the temperature differential among upper-atmosphere layers and the local topography and air circulation immediately around the telescope. The larger the diameter of the telescope, the more it is affected, because large telescopes have to peer through more air than smaller ones do. A telescope with a main lens or mirror 20 cm (8 inches) in diameter must look through a column of air 20 cm (8 inches) wide and about 16 km (10 miles) long.

## **THREE MAIN TYPES OF TELESCOPE OPTICAL SYSTEMS**

### **Refractor Telescope**

Although the classic design of the refractor has undergone significant changes since Galileo's time, the principle is still the same.

A main lens composed of two or more different pieces of optically figured glass brings light to a focus at the opposite end of the tube. Refractors have the advantage of rendering sharp high-contrast images, large image scales (due to higher focal ratios) and excellent resolution.

### **Newtonian Reflector Telescope**

Since its invention by Sir Isaac Newton in 1668, the reflector telescope has been very popular with amateur astronomers. It consists of a concave mirror positioned at the bottom of the tube that reflects and focuses starlight to a point just inside the tube's entrance. A flat secondary mirror redirects the light out the side of the tube and into an eyepiece lens.

Newtonian reflector telescopes provide accurate colour rendition of celestial objects and are less expensive for a given objective size than refractors. A 20-cm (8-inch) reflector costs about the same as a modest 10-cm (4-inch) refractor.

### **Schmidt-Cassegrain Telescope**

Telescopes that employ the features of both refractors and reflectors are said to be catadioptric. One of the most popular catadioptric designs is the Schmidt-Cassegrain telescope (SCT).



Show the cadets Attachment B.

The SCT has a spherical primary mirror at one end of the tube and a correcting lens at the other. The secondary mirror is mounted directly onto the correcting lens (or plate). This, in turn, redirects the light back down the tube and through a hole in the centre of the main mirror, where the eyepiece is located.

Folding the light path allows a manufacturer to produce a telescope with a focal length that is twice the length of the tube. Thus, SCTs are lightweight, portable, and produce excellent images.

---

### CONFIRMATION OF TEACHING POINT 2

#### QUESTIONS:

- Q1. Why must one never look at the sun through an unfiltered lens?
- Q2. What is seeing?
- Q3. What are three advantages of SCTs?

#### ANTICIPATED ANSWERS:

- A1. Focused sunlight will seriously damage a human eye.
- A2. Seeing refers to the steadiness of the image of a celestial object viewed through the telescope.
- A3. SCTs are lightweight, portable, and produce excellent images.

---

### Teaching Point 3

**Explain, demonstrate and have the cadets set up, operate and dismantle a telescope.**

Time: 30 min

Method: Demonstration and Performance

---



For this skill TP, it is recommended that instruction take the following format:

1. Explain and demonstrate the complete skill while cadets observe.
2. Explain and demonstrate each step required to complete the skill. Monitor cadets as they imitate each step.
3. Monitor the cadets' performance as they practice the complete skill.

Note: Assistant instructors may be employed to monitor the cadet's performance.

1. To set up a telescope:
  - a. remove all parts from their containers, ensuring that the optical tube is placed on a sturdy level surface;
  - b. set up the tripod;
  - c. attach the telescope to the tripod;

- d. attach the finderscope (if required);
  - e. attach the eyepiece (if required);
  - f. align the finderscope; and
  - g. align the telescope.
2. To operate and dismantle a telescope:
- a. adjust the right ascension;
  - b. adjust the declination;
  - c. remove the eyepiece (if required);
  - d. remove the finderscope (if required);
  - e. remove the telescope from its tripod;
  - f. collapse the tripod; and
  - g. return all parts to their containers.

Cadets must be careful when handling fragile equipment.

---

### **CONFIRMATION OF TEACHING POINT 3**

The cadets' participation in setting up, operating and dismantling telescopes will serve as the confirmation of this TP.

---

### **END OF LESSON CONFIRMATION**

#### **QUESTIONS:**

- Q1. How many axes of movement does an altazimuth mount have?
- Q2. Who invented the Newtonian reflector telescope design and in what year was it invented?
- Q3. What does folding the light path in a SCT allow the manufacturer to do?

#### **ANTICIPATED ANSWERS:**

- A1. Altazimuth mounts have two axes of movement.
- A2. Sir Isaac Newton in 1668.
- A3. Folding the light path allows a manufacturer to produce a telescope with a focal length that is twice the length of the tube.

---

### **CONCLUSION**

---

### **HOMEWORK / READING / PRACTICE**

Nil.

## **METHOD OF EVALUATION**

Nil.

## **CLOSING STATEMENT**

Knowing how to operate telescopes provides a fascinating way to become personally involved with an important aspect of aerospace development.

## **INSTRUCTOR NOTES / REMARKS**

Cadets who are qualified Advanced Aerospace may assist with this instruction.

---

## **REFERENCES**

---

C3-179 ISBN 1-55209-302-6 Dickenson, T. (2001). *Night watch: A practical guide to viewing the universe*. Willowdale, ON: Firefly Books.

C3-286 11073-INST. Celestron. (2006). *CPC series instructional manual*. Torrance, CA: Celestron.

THIS PAGE INTENTIONALLY LEFT BLANK



1	Control Panel (see below)	8	Optical Tube
2	Focus Knob	9	Schmidt Corrector Lens
3	Star Diagonal	10	Fork Arm
4	Hand Control	11	Carrying Handle
5	Eyepiece	12	Right Ascension Locking Knob
6	Finderscope	13	Tripod
7	Finderscope Quick Release Bracket	14	Accessory Tray / Center Support Bracket
A	Hand Control Port	D	Auto Guider Port
B	Auxiliary Ports	E	On/Off Switch
C	PC Interface Port	F	12v Input Jack

Figure A-1 Celestron Telescope

Note. From Celestron®, 2006, *CPC™ Series Instructional Manual*. Copyright 2006 by Celestron, Torrance, CA: Celestron.

THIS PAGE INTENTIONALLY LEFT BLANK



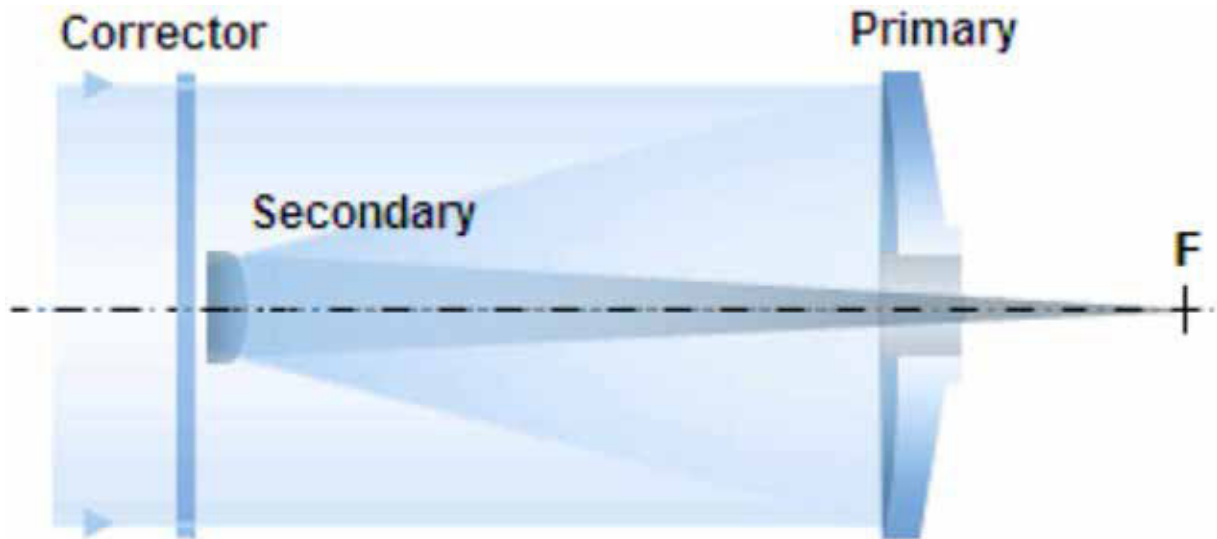

Figure B-1 Schmidt-Cassegrain Telescope Design

Note. From "telescopeOptics.net", by Vladimir Sacek, 2006, *Schmidt-Cassegrain Telescope (SCT)* Retrieved October 15, 2008, from <http://www.telescope-optics.net/SCT.htm>.

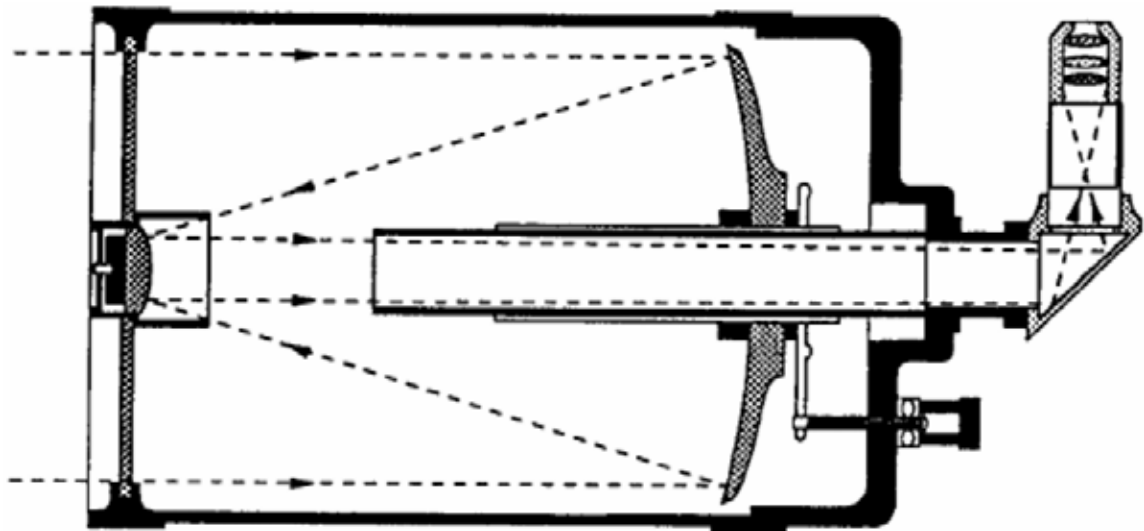

Figure B-2 Celestron SCT

Note. From Celestron®, 2006, *CPC™ Series Instructional Manual*. Copyright 2006 by Celestron, Torrance, CA: Celestron.

THIS PAGE INTENTIONALLY LEFT BLANK



**ROYAL CANADIAN AIR CADETS  
PROFICIENCY LEVEL FOUR  
INSTRUCTIONAL GUIDE**



**SECTION 10**

**EO C440.08 – WATCH *BLAST!* (BALLOON-BORNE  
LARGE APERTURE SUB-MILLIMETRE TELESCOPE)**

---

Total Time: 90 min

---

**PREPARATION**

---

**PRE-LESSON INSTRUCTIONS**

Resources needed for the delivery of this lesson are listed in the lesson specification located in A-CR-CCP-804/PG-001, *Proficiency Level Four Qualification Standard and Plan*, Chapter 4. Specific uses for said resources are identified throughout the instructional guide within the TP for which they are required.

Review the lesson content and become familiar with the material prior to delivering the lesson.

Create slides of the figures located at Attachments A and B.

Photocopy Attachment C for each cadet.

**PRE-LESSON ASSIGNMENT**

Nil.

**APPROACH**

An interactive lecture was chosen for TP 1 to introduce the cadets to cosmology and give an overview of the BLAST mission.

An in-class activity was chosen for TP 2 as it is an interactive way to reinforce cosmology, provoke thought and stimulate interest among cadets.

A group discussion was chosen for TP 3 as it allows the cadets to interact with their peers and share their knowledge, experiences, opinions, and feelings about cosmology using a balloon-borne large aperture sub-millimetre telescope.

---

**INTRODUCTION**

---

**REVIEW**

Nil.

**OBJECTIVES**

By the end of this lesson the cadet shall be expected to discuss the professional challenges that astrophysicists faced in the BLAST mission.

**IMPORTANCE**

It is important for cadets to discuss the professional challenges that astrophysicists face so that they understand how astrophysics is influenced by aerospace technologies.

**Teaching Point 1****Describe the BLAST mission.**

Time: 10 min

Method: Interactive Lecture



The word sub-millimetre, as it is used in this lesson, refers to the proximate wavelength of near-infrared electromagnetic energy, which can be thought of as the warmth of the sun. Most animals see the sun at visible wavelengths but they feel the sun in the far-infrared. Sub-millimetre near-infrared energy is blocked by atmospheric water vapour.

**OBSERVATION OF STAR FORMATION**

Astrophysicists are interested in learning more about how the earliest galaxies and stars were formed. However, these objects are often hidden by gas and dust so they cannot be seen in visible light. Fortunately, star births are fiery events. Heat from the newborn stars warms the surrounding dust, which then emits sub-millimetre radiation—a form of infrared electromagnetic radiation close to visible light. Infrared radiation, having wavelengths that are longer than visible light, can pass through dusty regions of space without being scattered. In order to detect much of this radiation, however, sub-millimetre telescopes must be built.

Water vapour in the Earth's atmosphere absorbs radiation across large parts of the infrared and sub-millimetre wavebands, making ground-based observations at some of these wavelengths impossible. Limited observations can be made from high-altitude balloons, such as BLAST, but space-based observatories such as the European Space Agency's Herschel are the only truly satisfactory solution to this problem.



Show the cadets the slide of Figure A-1 located at Attachment A.

**OBSERVATION OF GALAXY FORMATION**

When astronomers look further out into space, they are actually looking further back in time. Light travels incredibly fast and seems instantaneous at short distances on the Earth, but light from distant galaxies takes millions or even billions of years to reach Earth. The further out one looks into space, the longer that light has travelled. Observers are literally seeing the light of events that happened in the remote past. Looking further and further back, astronomers can develop a timeline for the evolution of the universe.



Show the cadets the slide of Figure A-2 located at Attachment A.



Learn more about infrared astronomy in The Cosmic Classroom: The Infrared Universe at <http://coolcosmos.ipac.caltech.edu/>

## THE BLAST MISSION DESIGN



Key words:

**Bolometers.** The sensors that detect sub-millimetre light.

**Gondola.** The large metal structure that holds the telescope, motors, and computers.

**Payload.** Anything dangling from the balloon.

**Star cameras.** Cameras that BLAST uses to orient itself in the sky.

Large unmanned helium balloons have long provided NASA with an inexpensive means to place payloads into a near-space environment. The unique capabilities of this program are crucial for the development of new technologies and payloads for NASA's space flight missions. They also offer essential training for the next generation of scientists, as can be seen in *BLAST!* As well, many important scientific observations are made from long-duration balloon flights.

BLAST used the Sun's energy to power instruments and took advantage of the Sun's continuous presence during the summers at the North and South Poles. Flying only in constant daylight, BLAST was ensured a steady source of power and a flight at a stable altitude. If the Sun were to set during the flight, the helium in a balloon would cool and it would drop to a lower altitude. At sunrise, the helium would heat and the balloon would rise.

BLAST needed a way to orient itself and point the telescope in the right direction. Although it had an onboard Global Positioning System (GPS), BLAST relied on the stars for its navigation. On top of the main mirror are two star cameras (long white tubes). These cameras took pictures of stars whose positions in the sky are well known. BLAST's computers then analyzed these reference points and, through a series of motors and gyroscopes, adjusted its orientation accordingly.

When landing, a remote-controlled system separated BLAST from the balloon and a parachute opened to help slow the telescope's descent. It took about 45 minutes for BLAST to reach the ground. The parachute was designed to then detach itself from the gondola. The precious hard drive, containing all of the data, had to be physically recovered. Recovery could be very difficult, depending on where BLAST landed.

In 2005, BLAST flew from Sweden to Canada while making moderately successful observations.



Show the cadets the slide of Figure B-1 located at Attachment B.

In 2006, BLAST flew over Antarctica while making very successful observations.



Show the cadets the slide of Figure B-2 located at Attachment B.

---

**CONFIRMATION OF TEACHING POINT 1****QUESTIONS:**

- Q1. Why are sub-millimetre telescopes, which observe infrared radiation, needed for studying star formation?
- Q2. Why must sub-millimetre telescopes operate in or near space?
- Q3. How long did it take BLAST to descend to the ground on its parachute?

**ANTICIPATED ANSWERS:**

- A1. Infrared radiation has wavelengths that are much longer than visible light, so it can pass through the dusty regions of space where stars are formed without being scattered.
- A2. Water vapour in the Earth's atmosphere absorbs radiation across large parts of the infrared and sub-millimetre wavebands, making ground-based observations at some of these wavelengths impossible.
- A3. It took about 45 minutes for BLAST to reach the ground.

---

**Teaching Point 2****Have the cadets watch *BLAST!***

Time: 55 min

Method: In-Class Activity

---

**ACTIVITY****OBJECTIVE**

The objective of this activity is to have the cadets watch the 53-minute motion picture *BLAST! (Balloon-Borne Large Aperture Sub-Millimetre Telescope)*.

**RESOURCES**

- *BLAST!* DVD, and
- Handout of Attachment C.

**ACTIVITY LAYOUT**

Nil.

**ACTIVITY INSTRUCTIONS**

1. Distribute Attachment C to each cadet.
2. Instruct the cadets to consider the questions posed on the handout while watching *BLAST!*
3. Play the entire 53-minute motion picture *BLAST! (Balloon-Borne Large Aperture Sub-Millimetre Telescope)*.

**SAFETY**

Nil.

---

## CONFIRMATION OF TEACHING POINT 2

The cadets' participation in the activity will serve as the confirmation of this TP.

---

### Teaching Point 3

**Discuss the science and the design of the BLAST mission.**

Time: 15 min

Method: Group Discussion

---

## BACKGROUND KNOWLEDGE

---



The point of the group discussion is to draw the following information from the group using the tips for answering / facilitating discussion and the suggested questions provided.

The background knowledge for this discussion is to be based on TP 1 and the material in the motion picture *BLAST! (Balloon-Borne Large Aperture Sub-Millimetre Telescope)*.

---

## GROUP DISCUSSION

---



### TIPS FOR ANSWERING / FACILITATING DISCUSSION:

- Establish ground rules for discussion, eg, everyone should listen respectfully; don't interrupt; only one person speaks at a time; no one's ideas should be made fun of; you can disagree with ideas but not with the person; try to understand others as much as you hope they understand you; etc.
- Sit the group in a circle, making sure all cadets can be seen by everyone else.
- Ask questions that will provoke thought; in other words avoid questions with yes or no answers.
- Manage time by ensuring the cadets stay on topic.
- Listen and respond in a way that indicates you have heard and understood the cadet. This can be done by paraphrasing their ideas.
- Give the cadets time to respond to your questions.
- Ensure every cadet has an opportunity to participate. One option is to go around the group and have each cadet answer the question with a short answer. Cadets must also have the option to pass if they wish.
- Additional questions should be prepared ahead of time.



**SUGGESTED QUESTIONS:**

- Q1. What are the main features of the professional relationship between the graduate student responsible for the Star Cameras and her two professors?
- Q2. Other than geography, what important similarities and links are there between Shackleton's missions and the BLAST mission?
- Q3. Why is it so important for visitors to McMurdo Station to be physically qualified (PQ)?
- Q4. How might a better understanding of the early universe affect everyday life?



Other questions and answers will develop throughout the group discussion. The group discussion should not be limited to only those suggested.



Reinforce those answers given and comments made during the group discussion, ensuring the teaching point has been covered.

**CONFIRMATION OF TEACHING POINT 3**

The cadets' participation in the group discussion will serve as the confirmation of this TP.

**END OF LESSON CONFIRMATION**

The cadets' participation in watching and discussing *BLAST!* will serve as the confirmation of this lesson.

**CONCLUSION****HOMEWORK / READING / PRACTICE**

Nil.

**METHOD OF EVALUATION**

Nil.

**CLOSING STATEMENT**

Astrophysicists face daunting challenges while pushing back the frontiers of science. Fortunately, the tools and the constant development of aerospace technologies allow scientific research to progress.

**INSTRUCTOR NOTES / REMARKS**

It is recommended that this EO be presented in three consecutive periods.

If EO C440.07 (Operate a Telescope) is selected, it is recommended that it be presented prior to this lesson.

---

**REFERENCES**

---

C3-295 Devlin, P. (Producer & Director). (2008). *BLAST!* [Motion picture]. United States: The ArtistShare Project.

C3-298 *BLAST (Balloon-Borne Large Aperture Sub-Millimetre Telescope)*. University of Pennsylvania Department of Physics and Astronomy. Retrieved January 30, 2009, from <http://blastexperiment.info/>

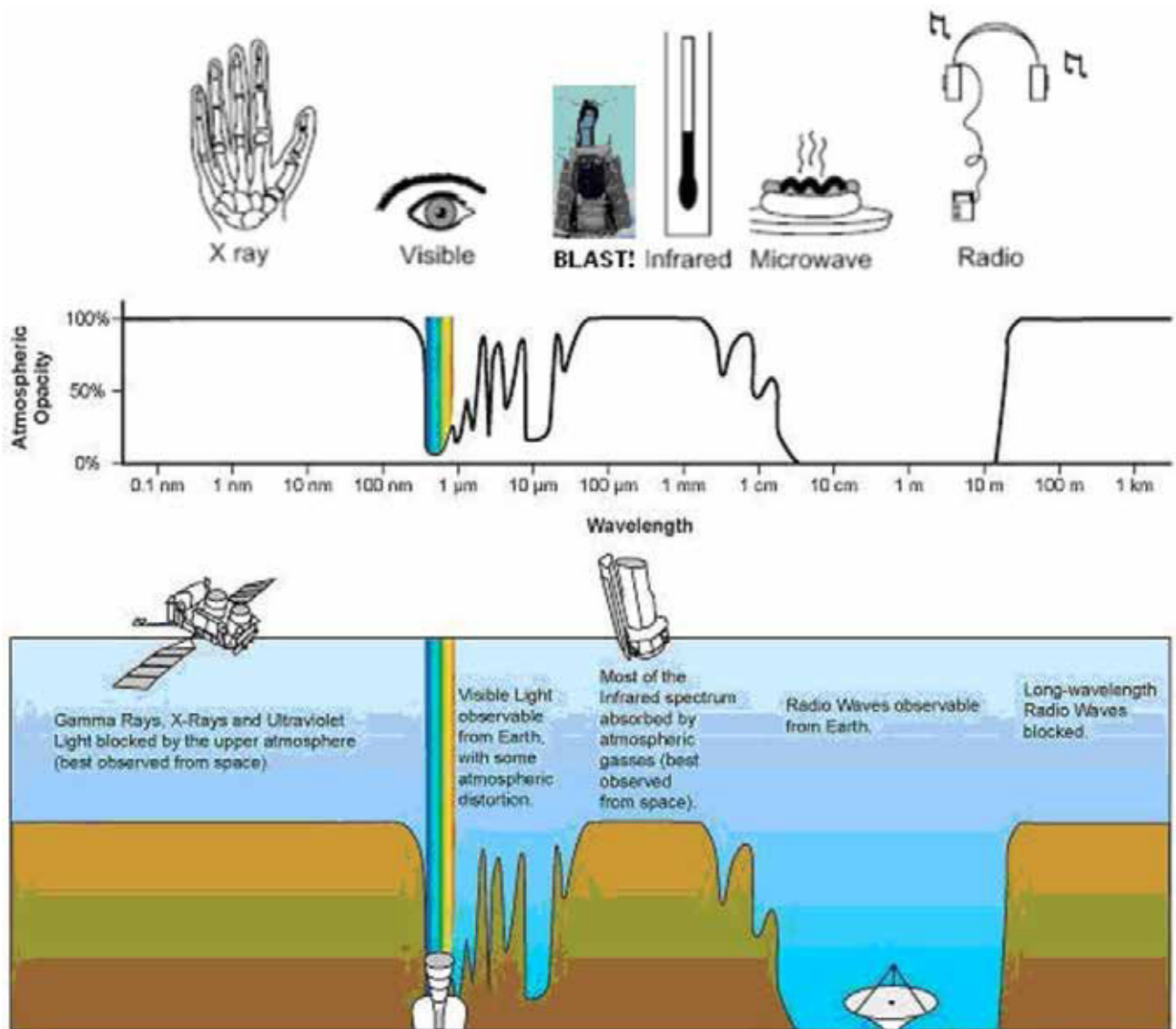

Figure A-1 The Electromagnetic Spectrum and Atmospheric Opacity

Note. From "Infrared Windows", *The Cosmic Classroom*, by California Institute of Technology, 2009. Retrieved March 27, 2009, from <http://www.ipac.caltech.edu/Outreach/Edu/Windows/irwindows.html>

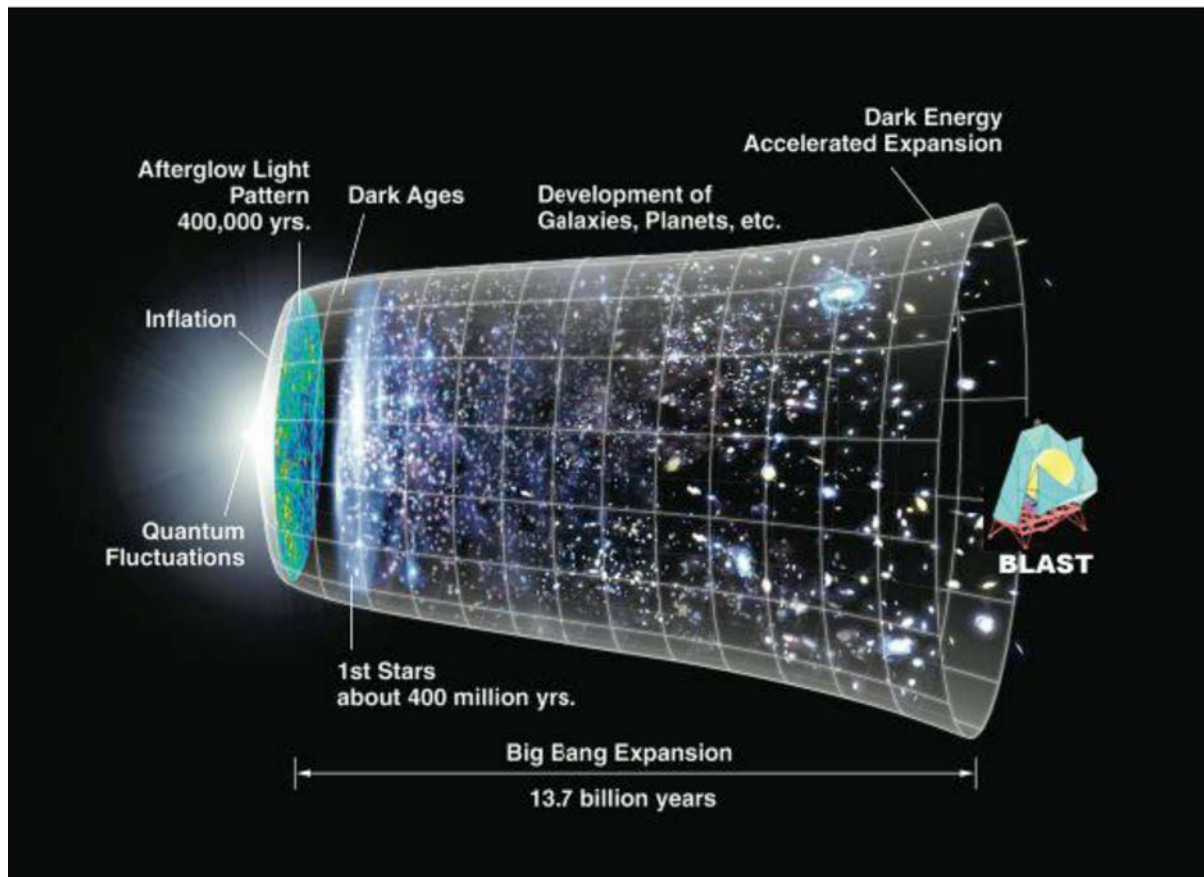

Figure A-2 The Big Bang

Note. From "BLAST: How It Works", *The Importance of BLAST*, by the ArtistShare Project, 2009. Retrieved March 28, 2009, from [http://www.blastthemovie.com/press/BLAST\\_HowItWorks.pdf](http://www.blastthemovie.com/press/BLAST_HowItWorks.pdf)

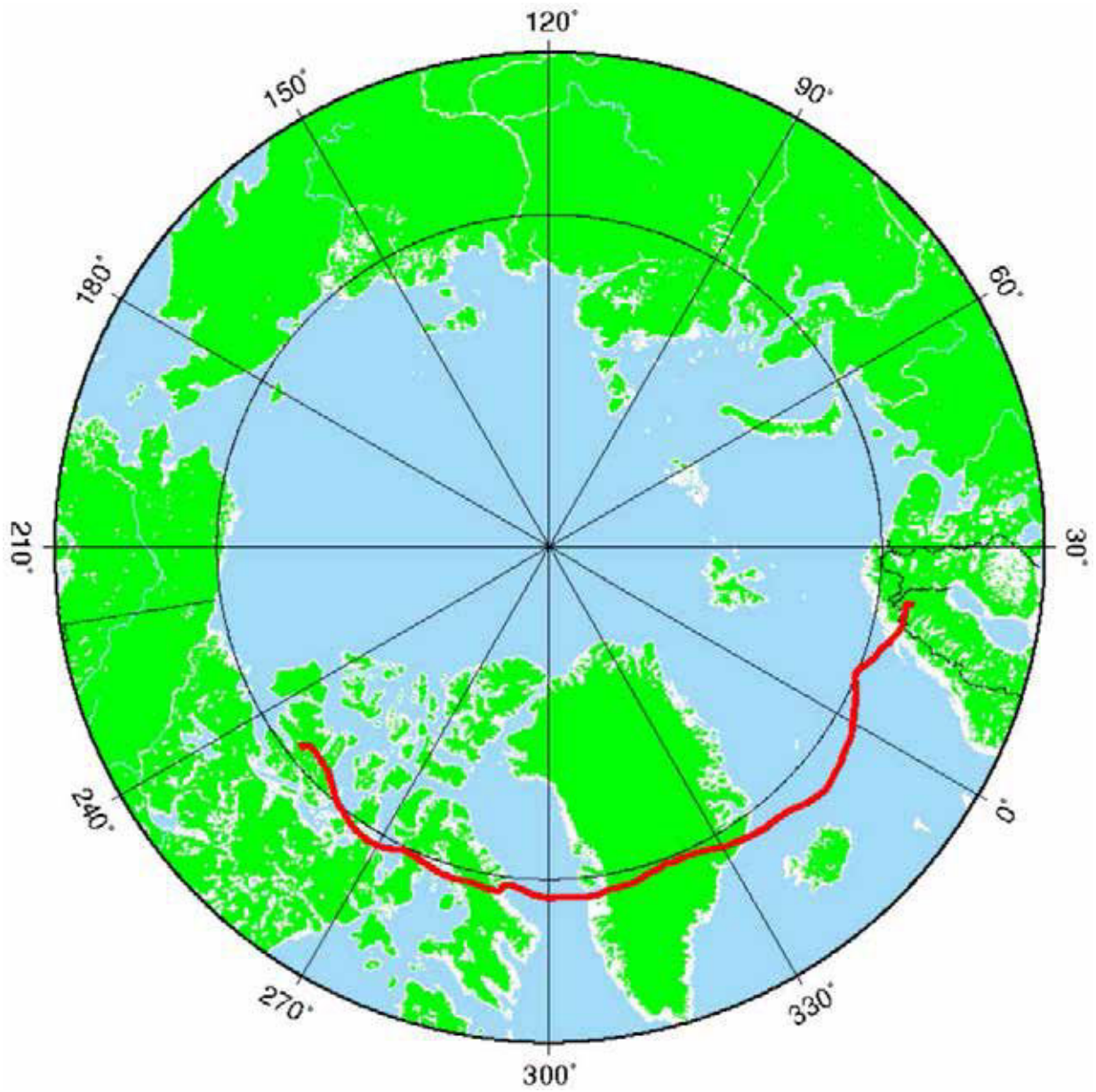

Figure B-1 BLAST Path 2005

*Note.* From "Flight Trajectory", *BLAST*, by Swedish Space Corporation, 2009. Retrieved March 28, 2009, from <http://www.ssc.se/?id=7082>



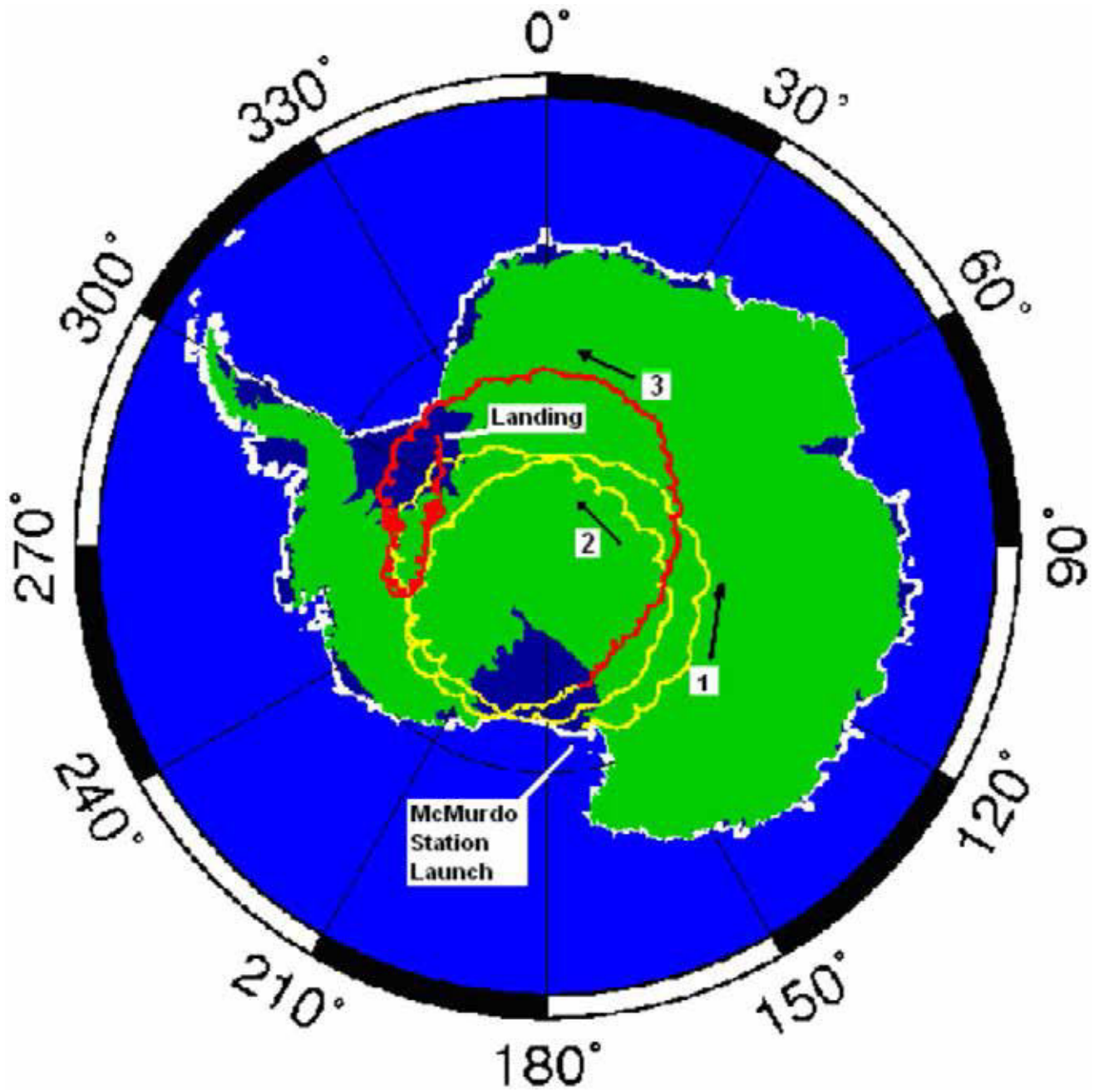

Figure B-2 BLAST Path 2006

Note. From "Flight Trajectory", *BLAST*, by Swedish Space Corporation, 2009.  
Retrieved March 28, 2009, from <http://www.nsf.nasa.gov/map/balloon4/balloon4.png>

**QUESTIONS TO CONSIDER WHILE WATCHING *BLAST!***

- What advantages are there in doing balloon missions during the Arctic and Antarctic summers?
- What is the nature of the professional relationship between graduate students and professors?
- Why do scientists attach great importance to priority—being the first to publish new knowledge?
- How might the European Space Agency's Herschel space telescope benefit from a balloon-based test of its cutting-edge infrared bolometers?
- Why do countries such as Canada and institutions such as York University see great value in this expensive pure science, which concerns events that happened billions of light-years away and billions of years ago?

THIS PAGE INTENTIONALLY LEFT BLANK





**ROYAL CANADIAN AIR CADETS**  
**PROFICIENCY LEVEL FOUR**  
**INSTRUCTIONAL GUIDE**



**SECTION 11**

**EO C440.09 – DESCRIBE THE RELATIONSHIP BETWEEN GRAVITY AND SPACE-TIME**

---

Total Time: 60 min

---

**PREPARATION**

---

**PRE-LESSON INSTRUCTIONS**

Resources needed for the delivery of this lesson are listed in the lesson specification located in A-CR-CCP-804/PG-001, *Proficiency Level Four Qualification Standard and Plan*, Chapter 4. Specific uses for said resources are identified throughout the instructional guide within the TP for which they are required.

Review the lesson content and become familiar with the material prior to delivering the lesson.

Obtain and cue the following six Windows Media Video (WMV) files from Reference C3-312 located at <http://einstein.stanford.edu/index.html>

- WMV file *Newtons\_Universe\_Anima*,
- WMV file *Einsteins\_Universe\_Anima*,
- WMV file *Rel\_gyro\_expt-anima*,
- WMV file *SConSquid*,
- WMV file *Simple\_expt\_anima*, and
- WMV file *DF-Satellite*.

Create slides of figures located at Attachment A.

Photocopy the Gravity and Space-Time handout located at Attachment B for each cadet.

Obtain a copy of Reference C3-310, *Gravity Probe B: An Educator's Guide*.

Obtain and cue the *Testing Einstein's Universe* DVD.

Obtain a large round coin, such as a Canadian two-dollar piece, for use in TP 2.

**PRE-LESSON ASSIGNMENT**

Nil.

**APPROACH**

An interactive lecture was chosen for TPs 1 and 2 to introduce theories of gravitation and give an overview of the Gravity Probe B mission.

An in-class activity was chosen for TPs 3 and 4 as it as it is an interactive way to reinforce the relationship between gravity and space-time, provoke thought, and stimulate interest among cadets.

---

## INTRODUCTION

---

### REVIEW

Nil.

### OBJECTIVES

By the end of this lesson the cadet shall be expected to describe the relationship between gravity and space-time.

### IMPORTANCE

It is important for cadets to describe the relationship between gravity and space-time because viewing gravity as a curvature of space-time explains more phenomena in the aerospace environment than the classical Newtonian view of gravity as a force of attraction.

**Teaching Point 1****Compare early ideas of gravity to gravitation under the theory of relativity.**

Time: 10 min

Method: Interactive Lecture

**NEWTON'S UNIVERSAL LAW OF GRAVITATION**

Show the cadets the WMV file *Newtons\_Universe\_Anima*.  
Running time is 1 minute, 8 seconds.

**GRAVITY AS A FORCE BETWEEN MASSES**

According to Newton's theory of gravity, all bodies possess the force of attraction called gravity. Larger masses, such as the Sun, attract smaller masses, such as the planets and comets, more strongly, causing the smaller masses to move toward the larger masses. In our solar system, the planets orbit the Sun due to the force of the Sun's gravity pulling them into this elliptical path. Comets soaring through the galaxy are curved toward the Sun due to gravity's pull.

**INSTANTANEOUS TRANSMISSION OF GRAVITY**

In *Principia* (1687), Newton stated, "there is a power of gravity pertaining to all bodies, proportional to the several quantities of matter which they contain." However, when Newton was questioned about how this "power of gravity" transmitted from one body to another, he responded, "I make no hypothesis."

Einstein, along with other scientists, began to question this conclusion around the turn of the 20<sup>th</sup> century. In the 19<sup>th</sup> century, Maxwell had shown that light propagated at a finite rate in a vacuum; 299 792 km / sec (185 871 miles / sec). In 1905, Einstein's theory of special relativity was based on the idea that this rate was the speed limit for all matter and energy in the universe. If gravity was a force that transmitted between masses in the same way light propagated through space, the force of gravity should be equally restricted to 299 792 km / sec. While moving nearly 300 000 km each second is extremely fast, it is not instantaneous.

**THE INTERDEPENDENCE OF SPACE AND TIME**

Newton believed that space and time were absolute or fixed entities and that gravity could be represented as an attractive force that somehow acted instantaneously between objects. Einstein determined that space and time are relative entities, interwoven into a "fabric," which he called space-time, and he realized that no force—not even gravity—could act faster than the speed of light. In Einstein's universe, the presence of celestial bodies causes space-time to warp or curve; and gravity is not a force, but rather the product of bodies moving in curved space-time.

Since space and time were separate concepts in Newton's physics, an object's position is simply described by three spatial coordinates. In Einstein's physics, space and time are combined into space-time so that when describing the position of an object one must include all four dimensions—the three spatial dimensions and time. The passage of time is relative to motion, so the time coordinate in the description of position describes time relative to a frame of reference, which is absolutely critical in Einstein's relativity.

## CURVATURE OF SPACE-TIME



Show the cadets the WMV video file *Einsteins\_Universe\_Anima*.  
Running time is 1 minute, 9 seconds.

In 1916, Einstein presented the world with this new understanding of the universe—his general theory of relativity. In his theory, space is not an empty void, but an invisible structure called space-time. Nor is space simply a three-dimensional grid through which matter and light and energy move. It is a four-dimensional structure called space-time whose shape is curved and twisted by the presence and motion of matter and energy.

Space-time curves around any mass. The presence of planets, stars and galaxies warps the fabric of space-time in a manner similar to a bowling ball warping a spandex sheet. The mass of the ball stretches the fabric and creates a dip or curve that gradually decreases the further one moves from the mass.

When a mass passes near a larger mass, it accelerates toward the larger mass because space-time itself is curved toward the larger mass. The smaller mass is not “attracted” to the larger mass by any force. The smaller mass simply follows the structure of curved space-time near the larger mass. For example, the massive Sun curves space-time around it, a curvature that reaches out to the edges of the solar system and beyond. The planets orbiting the Sun are following the curvature of space-time by the Sun.



Show the cadets the WMV file *Rel\_gyro\_expt-anima*.  
Running time is 3 minutes, 1 second.

---

## CONFIRMATION OF TEACHING POINT 1

### QUESTIONS:

- Q1. What was the speed limit for all matter and energy in the universe under Einstein's 1905 Special Theory of Relativity?
- Q2. How many coordinates describe an object's position in Newton's physics?
- Q3. How many coordinates describe an object's position in Einstein's physics?

### ANTICIPATED ANSWERS:

- A1. The speed of light propagating at a finite rate in a vacuum: 299 792 km / sec (185 871 miles / sec).
- A2. In Newton's physics, an object's position is simply described by three spatial coordinates.
- A3. In Einstein's physics, space and time are combined into space-time so that when describing the position of an object one must include all four dimensions—the three spatial dimensions and time.

**Teaching Point 2****Describe the Gravity Probe B (GP-B) mission.**

Time: 10 min

Method: Interactive Lecture

**GYROSCOPE OPERATION**

The gyroscope is a spinning wheel (rotor) in a universal mounting (gimbal) that allows its axle to be pointed in any direction.

Also known as rigidity in space, gyroscopic inertia is the tendency of a rotating object to remain in its plane of rotation. This allows the spin axis of a gyroscope to remain unchanged regardless of how the gimbal is moved around it.



Show the cadets the slide of Figure A-1 located at Attachment A.

Examples of rotating objects that exhibit rigidity in space are tops, gyroscopes, Frisbees, basketballs and any spinning planet. These objects tend to maintain their orientation in space.



Aircraft use gyroscopes for navigation, with the gyroscope maintaining the orientation of the universe so that relative changes in the aircraft's orientation can be measured. In the Gravity Probe B (GP-B) satellite, the gyroscope maintains its orientation relative to a distant guide star so that the changes in the orientation of space-time near Earth can be measured.

To work properly, the rotor must be kept spinning at a constant speed. Gyroscopic instruments may be powered by one or more power sources. In an aircraft, a gyroscope can be powered by moving air systems. In the GP-B satellite, the gyroscopes are powered by helium gas that is stored as liquid in the largest satellite component: the dewar.



**Dewar.** A double-walled vessel with a vacuum between the walls to reduce the transfer of heat, used for storing hot or cold liquid.



Show the cadets the slide of Figure A-2 located at Attachment A.

**THE SPIN AXIS OF A GYROSCOPE**

Spin a coin on its edge to show the cadets that it will remain upright while spinning. Demonstrate that the coin will not remain upright on its edge when it is not spinning.

It was predicted that the spin axis of each of GP-B's four gyroscopes move with the curvature and twist of local space-time around Earth. The only way this motion can be detected is by comparing each spin axis to a fixed line of reference. In this mission, the fixed reference line is the line between the telescope and the guide star: IM Pegasi. The telescope has to remain fixed on the exact centre of the guide star (within one milliarcond, or 1 millionth of an inch) throughout the mission or GP-B would lose its single critical reference line.



**SQUID (Superconducting QUantum Interference Device).** A device that monitors the spin axis orientation of the supercooled, superconducting gyroscope's perfectly unmarked, spherical rotor—without exerting significant torque on the spinning rotor.



Show the cadets the WMV video file *SConSquid*.  
Running time is 2 minutes, 12 seconds.

## GEODETIC EFFECT

Einstein's theory predicted that the presence of a mass in space, such as the Earth, will warp local space-time, creating a dip or curve in space-time. This is called geodetic effect.

## FRAME-DRAGGING EFFECT

One of the predictions of Einstein's general theory of relativity is that local space-time is twisted by the rotation of the Earth—any rotating mass will drag the local space-time frame of reference with it. The predicted drag is very small and fades as one travels further from the rotating mass, but the twist nearby can affect the paths of light, energy, and other masses.



Show the cadets the WMV video file *Simple\_expt\_anima*.  
Running time is 1 minute, 7 seconds.

## SPACECRAFT COMPONENTS

The GP-B satellite is composed of thousands of components, but the mission can be understood by considering only a few, to include:

- dewar,
- gyroscopes,
- star tracking telescope, and
- micro thrusters.



Show the cadets the WMV video file *DF-Satellite*.  
Running time is 4 minutes 25 seconds.

## CANADA'S CONTRIBUTION TO ORIENTATION CONTROL

Astrophysicists at York University measured and tracked the movement of GP-B's guide star, IM Pegasi, against a backdrop of more distant quasars. This allowed minute changes in the position of IM Pegasi to be taken into account when changes in gyroscope orientation was measured—in a system where angles of a millionth of a degree are of critical importance.



**Quasar.** Any of a class of starlike celestial objects, apparently of great size and remoteness, often associated with a spectrum with a large red shift and intense radio emission.

---

### CONFIRMATION OF TEACHING POINT 2

#### QUESTIONS:

- Q1. What is meant by rigidity in space?
- Q2. What is geodetic effect?
- Q3. What is frame-dragging effect?

#### ANTICIPATED ANSWERS:

- A1. Rigidity in space is the tendency of a rotating object to remain in its plane of rotation.
- A2. One of the predictions of Einstein's theory; the presence of a mass in space, such as the Earth, will warp local space-time, creating a dip or curve in space-time.
- A3. One of the predictions of Einstein's general theory of relativity; local space-time is twisted by the rotation of the Earth.

---

### Teaching Point 3

**Have the cadets watch *Testing Einstein's Universe*.**

Time: 25 min

Method: In-Class Activity

---

### ACTIVITY

#### OBJECTIVE

The objective of this activity is to have the cadets learn about the GP-B mission by watching *Testing Einstein's Universe* while finding answers to assigned questions.

#### RESOURCES

- Testing Einstein's Universe DVD,
- Gravity and Space-Time handout located at Attachment B for each cadet,
- Paper, and
- Pens / pencils.

## ACTIVITY LAYOUT

Nil.

## ACTIVITY INSTRUCTIONS

1. Distribute the Gravity and Space-Time handout located at Attachment B to each cadet.
2. Instruct the cadets to record their answers to the questions in the Gravity and Space-Time handout while watching *Testing Einstein's Universe*.
3. Have the cadets watch *Testing Einstein's Universe*.

## SAFETY

Nil.

---

## CONFIRMATION OF TEACHING POINT 3

The cadets' participation in the activity will serve as the confirmation of this TP.

---

## Teaching Point 4

**Conduct an activity to correct answers to the assigned questions.**

Time: 5 min

Method: In-Class Activity

---

## ACTIVITY

### OBJECTIVE

The objective of this activity is to have the cadets check their answers to the questions at Attachment B.

### RESOURCES

- Reference C3-310, *Gravity Probe B: An Educator's Guide*,
- Answer Key—Gravity And Space-Time located at Attachment C, and
- Completed Gravity and Space-Time handouts.

## ACTIVITY LAYOUT

Nil.

## ACTIVITY INSTRUCTIONS

1. Using the answer key located at Attachment C, read the answer to the question.
2. Have the cadets confirm their answer. If required, discuss any discrepancies, referring to Reference C3-310 as necessary.
3. Repeat Steps 1 and 2 for each question.

## SAFETY

Nil.



---

**CONFIRMATION OF TEACHING POINT 4**

The cadets' participation in the activity will serve as the confirmation of this TP.

---

**END OF LESSON CONFIRMATION**

The cadets' participation in watching *Testing Einstein's Universe* will serve as the confirmation of this lesson.

---

**CONCLUSION**

---

**HOMEWORK / READING / PRACTICE**

Nil.

**METHOD OF EVALUATION**

Nil.

**CLOSING STATEMENT**

The relationship between gravity and space-time is still theoretical. However, the relativistic theory of gravity as a manifestation of the curvature of space accounts for more natural phenomena than the classical Newtonian explanation.

**INSTRUCTOR NOTES / REMARKS**

Nil.

---

**REFERENCES**

---

C3-310 Range, S. K. (2004). *Gravity Probe B: An educator's guide*. Washington, DC: NASA. Retrieved February 6, 2009, from <http://einstein.stanford.edu/RESOURCES/education-index.html#guide>

C3-311 Bartel, N. (Producer & Director). (2003). *Testing Einstein's universe* [Motion picture]. Canada: York University.

C3-312 Range, S. K. (2008). *Gravity Probe B: Testing Einstein's universe*. Retrieved February 6, 2009, from <http://einstein.stanford.edu/index.html>

THIS PAGE INTENTIONALLY LEFT BLANK

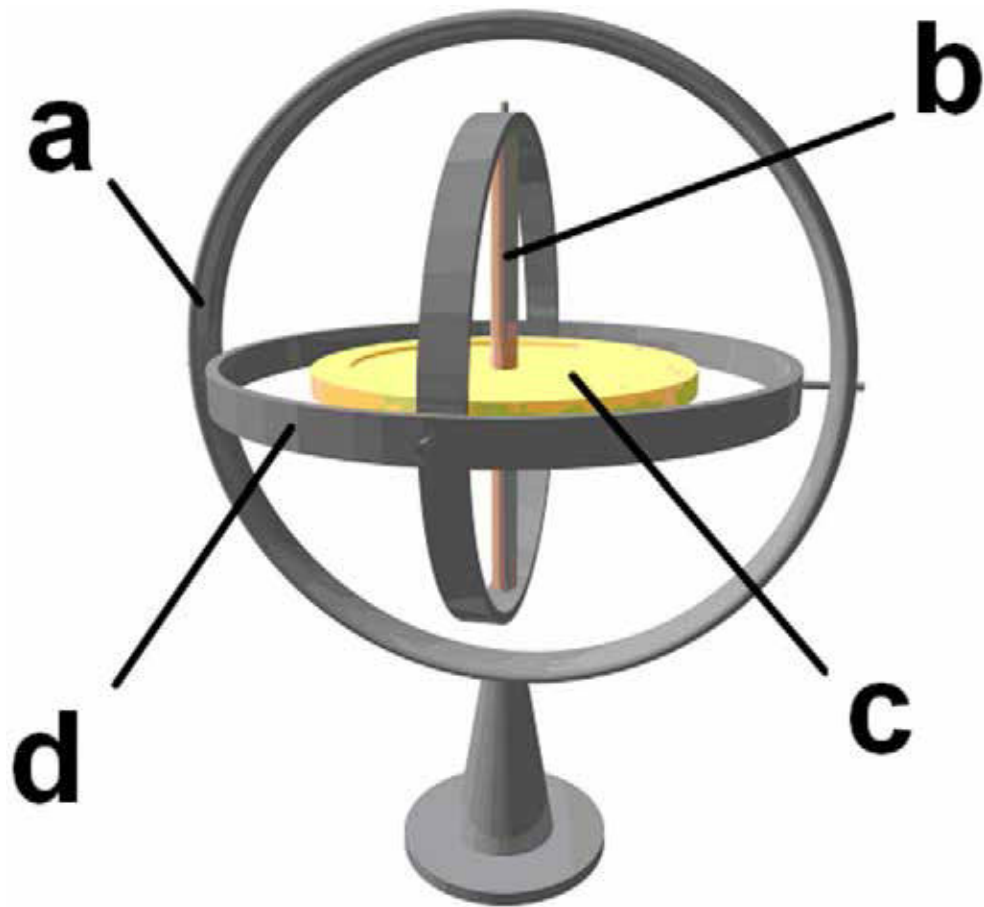

Figure A-1 Gyroscope

*Note.* From "3D Gyroscope", *Wikimedia*. Retrieved November 18, 2008, from [http://upload.wikimedia.org/wikipedia/commons/e/e2/3D\\_Gyroscope.png](http://upload.wikimedia.org/wikipedia/commons/e/e2/3D_Gyroscope.png)

- a. Gyroscope frame
- b. Spin axis
- c. Rotor
- d. Gimbal



Figure A-2 Gravity Probe B Dewar

*Note.* From *Gravity Probe B: An Educator's Guide*, (p. 30), by S. Shannon, 2004. Washington, DC: NASA.

**GRAVITY, SPACE-TIME AND GP-B**

Q1. Name two 20<sup>th</sup> century tests of Einstein's general theory of relativity.

- \_\_\_\_\_
- \_\_\_\_\_

Q2. Why was Gravity Probe B placed into a low orbit even though that meant it would be buffeted by the upper atmosphere?

---

---

Q3. Why was Gravity Probe B placed into a polar orbit?

---

---

Q4. What were three uses of the liquid helium in Gravity Probe B's dewar?

- \_\_\_\_\_
- \_\_\_\_\_
- \_\_\_\_\_

Q5. In Einstein's Equivalence Principle, what is said to be equivalent?

---

---

Q6. What is the significance of Gravity Probe B's drag-free status?

---

---

THIS PAGE INTENTIONALLY LEFT BLANK

**ANSWER KEY—GRAVITY, SPACE-TIME AND GP-B**

- Q1. Name two 20<sup>th</sup> Century tests of Einstein's general theory of relativity.
- A1. Reference C3-310 (pp. 13–14): Any two of:
- precession of Mercury's orbit,
  - starlight deflection during a solar eclipse,
  - gravitational redshift, and
  - shapiro time delay.
- Q2. Why was Gravity Probe B placed into a low orbit even though that meant it would be buffeted by the upper atmosphere?
- A2. Reference C3-310 (p. 32): The effects of local space-time (its curve and twist) weaken dramatically as one moves farther from the Earth. Gravity Probe B was given an orbit that would get it as close to the Earth as possible, to see the space-time effects more clearly.
- Q3. Why was Gravity Probe B placed into a polar orbit?
- A3. WMV file *Rel\_gyro\_expt-anima*: In a polar orbit the two effects, geodetic and frame-dragging, occur at right angles, providing maximum separation. This makes it possible for a gyroscope to measure both effects simultaneously.
- Q4. What were three uses of the liquid helium in Gravity Probe B's dewar?
- A4. Three uses of the helium in Gravity Probe B's dewar include:
- Reference C3-310 (p. 25): Spinning the gyroscopes,
  - Reference C3-310 (p. 30): Supercooling the instruments, and
  - Reference C3-310 (p. 32): Powering the micro-thrusters.
- Q5. In Einstein's equivalence principle, what is said to be equivalent?
- A5. Reference C3-310 (p. 25): An experience of gravity is equivalent to an experience of acceleration.
- Q6. What is the significance of Gravity Probe B's drag-free status?
- A6. Reference C3-310 (p. 29): The slightest amount of heat or pressure, the influence of a magnetic field, any kind of gravitational acceleration, or the tiniest amount of atmospheric turbulence will destroy the accuracy of the instrument.

THIS PAGE INTENTIONALLY LEFT BLANK





**ROYAL CANADIAN AIR CADETS  
PROFICIENCY LEVEL FOUR  
INSTRUCTIONAL GUIDE**



**SECTION 12**

**EO C440.10 – DISCUSS KINETIC AND POTENTIAL ENERGY**

---

Total Time:	30 min
-------------	--------

---

**PREPARATION**

---

**PRE-LESSON INSTRUCTIONS**

Resources needed for the delivery of this lesson are listed in the lesson specification located in A-CR-CCP-804/PG-001, *Proficiency Level Four Qualification Standard and Plan*, Chapter 4. Specific uses for said resources are identified throughout the instructional guide within the TP for which they are required.

Review the lesson content and become familiar with the material prior to delivering the lesson.

Photocopy Attachment A for each group of four cadets for TP 3.

Gather materials needed for the activities in TPs 1–3.

**PRE-LESSON ASSIGNMENT**

Nil.

**APPROACH**

An in-class activity was chosen for this lesson as it is an interactive way to provoke thought about energy and stimulate interest in kinetic and potential energy among cadets.

---

**INTRODUCTION**

---

**REVIEW**

Nil.

**OBJECTIVES**

By the end of this lesson the cadet shall be expected to discuss kinetic and potential energy.

**IMPORTANCE**

It is important for cadets to understand the relationship between kinetic and potential energy so that they can recognize the requirements, applications and effects of propulsion systems, especially in a microgravity environment.

---

**Teaching Point 1****Explore the storage and conversion of kinetic and potential energy in a gravitational system.**

Time: 5 min

Method: In-Class Activity

---

**Kinetic energy.** Energy of motion. A falling yo-yo has kinetic energy.

**Potential energy.** Energy that is stored in an object. A yo-yo held above the floor has potential energy because gravity pulls it down.

Kinetic energy can be converted into potential energy and potential energy can be converted back into kinetic energy. This can be seen in the repeated actions of a yo-yo as it goes through its cycles.

Before the yo-yo begins its fall, it has stored energy due to its position above the floor. At the top of its cycle it has its maximum potential energy. As it starts to fall the potential energy begins to be changed into the kinetic energy of falling—but the string, being wound around the yo-yo spindle, converts the kinetic energy of falling into kinetic energy of rotation.

At the bottom, the yo-yo's potential energy has been converted into, first, kinetic energy of falling, which was then converted to rotation. The yo-yo will now have its maximum kinetic energy of rotation. When the string is tightly extended at the bottom of the yo-yo's cycle, its kinetic energy of rotation can be used, by a competent yo-yo operator, to wind the string back around the yo-yo's spindle. It helps to add energy to each cycle of the yo-yo by speeding it on its downward leg. This is necessary due to energy losses from friction.

---

**ACTIVITY****OBJECTIVE**

The objective of this activity is to have the cadets explore the storage and conversion of kinetic and potential energy in a gravitational system by operating a yo-yo.

**RESOURCES**

Yo-yo (one per cadet).

**ACTIVITY LAYOUT**

Nil.

**ACTIVITY INSTRUCTIONS**

1. Distribute a yo-yo to each cadet.
2. Explain the following rules of this competition:
  - a. Cadets shall stand to operate their yo-yos.
  - b. Yo-yos shall be operated vertically only.
  - c. Cadets shall return to their seats when their yo-yo stops.
  - d. The last cadet standing wins the competition.
3. Have the cadets prepare by winding the string around the yo-yo spindle.
4. On command, have the cadets begin cycling their yo-yo.

**SAFETY**

Cadets shall take care to not hit anyone or anything with their yo-yo.

**CONFIRMATION OF TEACHING POINT 1**

The cadets' participation in the yo-yo activity will serve as the confirmation of this TP.

**Teaching Point 2**

**Explore the storage and conversion of kinetic and potential energy in an elastic system.**

Time: 5 min

Method: In-Class Activity



An elastic band flying through the air has kinetic energy.

When an elastic band is stretched, it gains potential energy. As the elastic band is released, stored potential energy is changed to the kinetic energy of motion.

**ACTIVITY****OBJECTIVE**

The objective of this activity is to have the cadets explore the storage and conversion of kinetic and potential energy in an elastic system by using elastic bands in a target competition.

**RESOURCES**

Elastic bands (two different colours).

**ACTIVITY LAYOUT**

1. Clear an area at least 3 m on each side of a 2-m line on the floor.
2. Place an empty waste paper basket 3 m from the line.

**ACTIVITY INSTRUCTIONS**

1. Divide the cadets into two teams.
2. Give each team three elastic bands per cadet, with different colours for each team.
3. Have one member of each team advance to the line and attempt to shoot one elastic band into the waste paper basket by stretching and releasing it.
4. Have each cadet repeat Step 3 three times.
5. Declare the winner based on the team that has the most elastic bands in the waste paper basket.

**SAFETY**

Cadets shall not aim an elastic band at another person.

**CONFIRMATION OF TEACHING POINT 2**

The cadets' participation in the elastic band activity will serve as the confirmation of this TP.

**Teaching Point 3****Explore the effects of velocity and mass in the expenditure of energy.**

Time: 15 min

Method: In-Class Activity



This TP consists of making a series of craters of various sizes. Point out to the cadets the features of the craters they create as shown in Figure 1 (Lunar crater Aristarchus, 42 km in diameter, located west of Mare Imbrium).

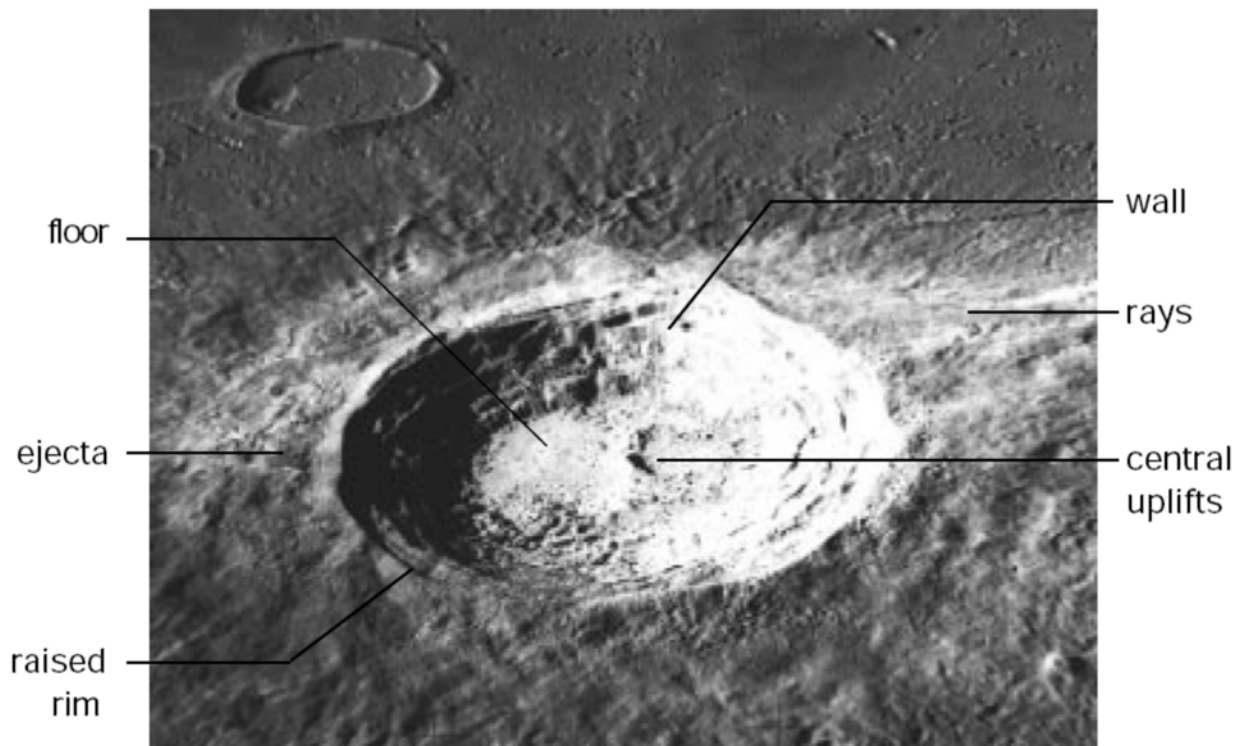

Figure 1 Parts of a Crater

*Note:* From NASA, 1997, *Exploring the Moon: A Teacher's Guide With Activities*. Retrieved September 30, 2008, from <http://lunar.arc.nasa.gov/education/pdf/expmoon.pdf>



The energy of a moving object is equal to its mass (weight) multiplied by the square of its velocity, or  $E = mv^2$ . An object travelling twice as fast will therefore deliver four times the energy at impact, and an object travelling three times as fast results in nine times the energy at impact.

**ACTIVITY****OBJECTIVE**

The objective of this activity is to have the cadets explore the effects of velocity and mass in the expenditure of energy through the creation of a series of craters.

## RESOURCES

- Impact Crater Data Chart located at Attachment A,
- Plastic tubs approximately 10 cm deep, 20 cm wide and 30 cm long,
- Ruler marked in millimetres,
- Sand (half tub),
- Cornstarch (half tub), and
- Impactors, to include:
  - marbles of various sizes,
  - ball bearings of various sizes,
  - wooden balls of various sizes, and
  - golf balls.

## ACTIVITY LAYOUT

1. Place a tub of mixed dry sand and cornstarch in the centre of an area that is clear at least 3 m on each side.
2. During this activity, the sand mixture may fall onto the floor and the cornstarch may even be dispersed into the air. Spread newspaper under the pan(s) to catch spills or conduct the activity outside.

## ACTIVITY INSTRUCTIONS

1. Divide the cadets into groups of no more than four.
2. Distribute one Impact Crater Data Chart located at Attachment A to each group.
3. Have the cadets drop impactors of various sizes into the tub of mixed sand and cornstarch from a height of 30 cm as per Attachment A.
4. Have the cadets measure the resulting craters and then select an effective impactor for the following exercise (an effective impactor will produce maximum rays, crater walls, a raised rim, and ejecta as shown in Figure 1, but it may not be possible to create a central uplift).
5. Have the cadets smooth and resurface the material in the pan before each impact. The material does not need to be packed down.



Shaking or tilting the pan back and forth produces a smooth surface. Better experimental control is achieved with consistent handling of the materials. For instance, cratering results may vary if the material is packed down for some trials and not for others.

6. Explain to the cadets that because of the low velocity of the experimental impactors compared with the velocity of real impactors, the experimental impact craters may not have significantly raised rims or central uplifts.
7. Have the cadets drop the impactor from increasing heights and record their data as per Attachment A.
8. Have the cadets analyze their results. They should observe that the higher drop height and resulting increase in velocity of the impactor creates a larger crater and spreads the ejecta out further.

## **SAFETY**

Nil.

---

## **CONFIRMATION OF TEACHING POINT 3**

The cadets' participation in the crater activity will serve as the confirmation of this TP.

---

## **END OF LESSON CONFIRMATION**

The cadets' participation in exploring the storage and conversion of kinetic and potential energy in a gravitational system, the conversion of kinetic and potential energy in an elastic system, and the effects of velocity and mass in the expenditure of energy will serve as the confirmation of this lesson.

---

## **CONCLUSION**

---

## **HOMEWORK / READING / PRACTICE**

Nil.

## **METHOD OF EVALUATION**

Nil.

## **CLOSING STATEMENT**

A coasting spaceship has kinetic energy that was gained from the potential energy stored in its fuel. A good understanding of the relationship between kinetic and potential energy helps to recognize the requirements, applications and effects of propulsion systems.

## **INSTRUCTOR NOTES / REMARKS**

Cadets who are qualified Advanced Aerospace may assist with this instruction.

---

## **REFERENCES**

---

C3-262 Canadian Space Agency. (2003). *Orbital mechanics: Energy*. Retrieved September 30, 2008, from <http://www.space.gc.ca/eng/educators/resources/orbital/energy.asp>

C3-263 EG-1997-10-116-HQ NASA. (1997). *Exploring the moon: A teacher's guide with activities*. Retrieved September 30, 2008, from <http://lunar.arc.nasa.gov/education/pdf/expmoon.pdf>

Name: \_\_\_\_\_

Date: \_\_\_\_\_

impactor #   
 gm

### Impact Craters - Data Chart

		trial 1	trial 2	trial 3	total	average
drop height = 30 cm velocity = 242 cm/s	crater diameter					
	crater depth					
	average length of all rays					
drop height = 60 cm velocity = 343 cm/s	crater diameter					
	crater depth					
	average length of all rays					
drop height = 90 cm velocity = 420 cm/s	crater diameter					
	crater depth					
	average length of all rays					
drop height = 2 m velocity = 626 cm/s	crater diameter					
	crater depth					
	average length of all rays					

Figure A-1 Impact Crater Data Chart

Note: From NASA, 1997, *Exploring the Moon: A Teacher's Guide With Activities*.  
 Retrieved September 30, 2008, from <http://lunar.arc.nasa.gov/education/pdf/expmoon.pdf>

THIS PAGE INTENTIONALLY LEFT BLANK





**ROYAL CANADIAN AIR CADETS  
PROFICIENCY LEVEL FOUR  
INSTRUCTIONAL GUIDE**



**SECTION 13**

**EO C440.11 – WATCH EINSTEIN'S BIG IDEA**

---

Total Time:	150 min
-------------	---------

---

**PREPARATION**

---

**PRE-LESSON INSTRUCTIONS**

Resources needed for the delivery of this lesson are listed in the lesson specification located in A-CR-CCP-804/PG-001, *Proficiency Level Four Qualification Standard and Plan*, Chapter 4. Specific uses for said resources are identified throughout the instructional guide within the TP for which they are required.

Review the lesson content and become familiar with the material prior to delivering the lesson.

Photocopy Attachment A for each cadet.

Photocopy the note template handout located at Attachment B.

Cue the DVD *Einstein's Big Idea*.

**PRE-LESSON ASSIGNMENT**

Nil.

**APPROACH**

An in-class activity was chosen for this lesson as it is an interactive way to provoke thought and stimulate interest among cadets about the development of the formula  $E=mc^2$ .

---

**INTRODUCTION**

---

**REVIEW**

Nil.

**OBJECTIVES**

By the end of this lesson the cadet shall be expected to discuss the history of the formula  $E=mc^2$ .

**IMPORTANCE**

It is important for cadets to be able to discuss the history of the formula  $E=mc^2$  so that they recognize that science is a team effort, which transcends both national boundaries and the centuries.

---

**Teaching Point 1**

**Conduct an activity where the cadets to define energy and describe kinds of energy and differences between sources of energy.**

Time: 5 min

Method: In-Class Activity

---



The term energy refers to the amount of work that can be performed by a system:

**Potential energy.** The energy an object has due to its position or condition.

**Kinetic energy.** The energy due to the motion of an object.

---

**ACTIVITY**

**OBJECTIVE**

The objective of this activity is to have the cadets brainstorm definitions of energy and to describe kinds of energy and differences between sources of energy.

**RESOURCES**

Nil.

**ACTIVITY LAYOUT**

Nil.

**ACTIVITY INSTRUCTIONS**

1. Have the cadets brainstorm definitions of energy.
2. Have the cadets list what kinds of energy they have used today.
3. Have the cadets list sources of energy (eg, sun, oil, natural gas, gasoline, wind, hydroelectric, nuclear, coal, wood, and food).
4. Point out that many of these are means of storing energy (eg, chemical storage such as natural gas) or forms of energy that are converted before becoming useful (eg, electrical energy converted to heat or mechanical energy).

**SAFETY**

Nil.

---

**CONFIRMATION OF TEACHING POINT 1**

The cadets' participation in the activity will serve as the confirmation of this TP.

---

**Teaching Point 2****Have the cadets determine that atoms of matter have mass.**

Time: 10 min

Method: In-Class Activity

---



The nucleus of an atom is made up of protons and neutrons in a cluster. Virtually all the mass of the atom resides in the nucleus. The nucleus is held together by the tight pull of what is known to chemists and physicists as the "strong force". This force between the protons and neutrons overcomes the repulsive electrical force that would, according to the rules of electricity, otherwise push the positively-charged protons apart.

---

**ACTIVITY****OBJECTIVE**

The objective of this activity is to have the cadets determine that the atoms that constitute matter have mass.

**RESOURCES**

Handout located at Attachment A.

**ACTIVITY LAYOUT**

Nil.

**ACTIVITY INSTRUCTIONS**

1. Make a list of common materials on a flip chart or whiteboard, to include:
  - a. air,
  - b. water,
  - c. living organisms,
  - d. the sun, and
  - e. jewellery
2. Have the cadets identify the primary elements in air (nitrogen, oxygen), water (hydrogen, oxygen), living organisms (carbon, nitrogen, oxygen, hydrogen), the sun (hydrogen, helium), and jewellery (nickel, silver, gold).
3. Have the cadets locate those elements in a periodic table and determine their atomic mass.

**SAFETY**

Nil.

---

**CONFIRMATION OF TEACHING POINT 2**

The cadets' participation in the activity will serve as the confirmation of this TP.

---

**Teaching Point 3**

**Have the cadets watch *Einstein's Big Idea* and make notes on topics assigned.**

Time: 110 min

Method: In-Class Activity

---



Before watching *Einstein's Big Idea*, arrange for the cadets, singly or in groups, to make notes using the six handouts located at Attachment B.

The six note templates do not correspond to chapters in the motion picture. Information for the note templates will be found throughout the motion picture.

---

**ACTIVITY**

**OBJECTIVE**

The objective of this activity is to have the cadets take notes on their assigned topics while watching *Einstein's Big Idea*.

**RESOURCES**

- *Einstein's Big Idea* DVD,
- Note template handouts located at Attachment B, and
- Pens / pencils.

**ACTIVITY LAYOUT**

Nil.

**ACTIVITY INSTRUCTIONS**

1. Distribute the six note template handouts located at Attachment B. Each cadet should have one of the six note templates. If there are more than six cadets, they may form teams.
2. Ensure each template located at Attachment B has at least one cadet assigned to it.
3. Play *Einstein's Big Idea*.
4. Have the cadets, while watching *Einstein's Big Idea*, take notes on their assigned topics.

**SAFETY**

Nil.

---

**CONFIRMATION OF TEACHING POINT 3**

The cadets' participation in the activity will serve as the confirmation of this TP.

---

**Teaching Point 4****Conduct an activity to create a timeline of the development of the formula  $E=mc^2$ .**

Time: 15 min

Method: In-Class Activity

---

**ACTIVITY****OBJECTIVE**

The objective of this activity is to have the cadets construct a timeline showing the development of the formula  $E=mc^2$ .

**RESOURCES**

- String,
- Paper clips,
- Pens / pencils, and
- Completed note templates from TP 3.

**ACTIVITY LAYOUT**

Place a 3-m string across a classroom wall. Create a timeline ranging from 1700 to 1950 from the string by hanging paper century markers on the string with paper clips.

**ACTIVITY INSTRUCTIONS**

1. Have a cadet describe an assigned topic and the scientist's challenges and accomplishments.
2. Have the cadet clip the notes about that scientist to the appropriate place on the string.
3. Repeat for each scientist or team of scientists.
4. Draw the cadets' attention to the way that scientific research crossed national frontiers over very long periods of time. Point out that although historic contributors such as Socrates, Aristotle, Leonardo da Vinci and Sir Isaac Newton are not shown on this short timeline, their ideas were essential to the discoveries in *Einstein's Big Idea*.

**SAFETY**Nil.

---

**CONFIRMATION OF TEACHING POINT 4**

The cadets' participation in the activity will serve as the confirmation of this TP.

---

**END OF LESSON CONFIRMATION**

The cadets' participation in the timeline construction activity will serve as the confirmation of this lesson.

---

## CONCLUSION

---

### HOMEWORK / READING / PRACTICE

Nil.

### METHOD OF EVALUATION

Nil.

### CLOSING STATEMENT

Science is a team effort that transcends national boundaries and time. Our understanding of matter and energy are still very incomplete; while today we know more about light than Faraday and Maxwell, more about mass than the Lavoisiers and more about energy than du Châtelet, we have nevertheless scarcely begun. Science is teamwork in progress and it is not too late to join the team.

### INSTRUCTOR NOTES / REMARKS

If EO C440.09 (Describe the Relationship Between Gravity and Space-Time) or EO C440.10 (Discuss Kinetic and Potential Energy) are also selected, they should be presented prior to this lesson to introduce concepts of energy.

It is recommended that Chapters 1–6 of Einstein's Big Idea be presented in three consecutive periods and Chapters 7–9 be presented in two consecutive periods, all on two consecutive training days.

---

## REFERENCES

---

C3-319 NOVA. (2005). *Teacher's guide: Einstein's big idea*. Retrieved January 30, 2009 from <http://www.pbs.org/wgbh/nova/einstein/>

C3-320 Johnstone, G. (Producer & Director). (2005). *Einstein's big idea* [Motion picture]. United States: WBGH Educational Foundation.

**Table of Element Abbreviations and Names**

Ac	Actinium	Ha	Hahnium	P	Phosphorus
Ag	Silver	He	Helium	Pr	Praseodymium
Al	Aluminum	Hf	Hafnium	Pt	Platinum
Am	Americium	Hg	Mercury	Pu	Plutonium
Ar	Argon	H	Hydrogen	Ra	Radium
As	Arsenic	Ho	Holmium	Rb	Rubidium
At	Astatine	Hs	Hassium	Re	Rhenium
Au	Gold	I	Iodine	Rf	Rutherfordium
Ba	Barium	In	Indium	Rh	Rhodium
B	Boron	Ir	Iridium	Rn	Radon
Be	Beryllium	Kr	Krypton	Ru	Ruthenium
Bi	Bismuth	La	Lanthanum	Sb	Antimony
Bk	Berkelium	Li	Lithium	Sc	Scandium
Br	Bromine	Lr	Lawrencium	Se	Selenium
Ca	Calcium	Lu	Lutetium	Sg	Seaborgium
C	Carbon	Md	Mendelevium	Si	Silicon
Cd	Cadmium	Mg	Magnesium	Sm	Samarium
Ce	Cerium	Mn	Manganese	Sn	Tin
Cf	Californium	Mo	Molybdenum	Sr	Strontium
Cl	Chlorine	Mt	Meitnerium	S	Sulfur
Cm	Curium	Na	Sodium	Ta	Tantalum
Co	Cobalt	Nb	Niobium	Tb	Terbium
Cr	Chromium	Nd	Neodymium	Tc	Technetium
Cs	Cesium	Ne	Neon	Te	Tellurium
Cu	Copper	Ni	Nickel	Th	Thorium
Dy	Dysprosium	N	Nitrogen	Ti	Titanium
Er	Erbium	No	Nobelium	Tl	Thallium
Es	Einsteinium	Np	Neptunium	Tm	Thulium
Eu	Europium	Ns	Neilsborium	U	Uranium
Fe	Iron	O	Oxygen	V	Vanadium
F	Fluorine	Os	Osmium	W	Tungsten
Fm	Fermium	Pa	Protactinium	Xe	Xenon
Fr	Francium	Pb	Lead	Yb	Ytterbium
Ga	Gallium	Pd	Palladium	Y	Yttrium
Gd	Gadolinium	Pm	Promethium	Zn	Zinc
Ge	Germanium	Po	Polonium	Zr	Zirconium

Figure A-1 Element Abbreviations and Names

Note: From "Los Alamos National Laboratory's Chemistry Division Presents", 2004, *Periodic Table of the Elements: A Resource for Elementary, Middle School, and High School Students*. Retrieved February 11, 2009, from <http://periodic.lanl.gov/default.htm>

### Simplified Periodic Table of the Elements

1 <b>H</b> 1.008																	2 <b>He</b> 4.003																												
3 <b>Li</b> 6.941	4 <b>Be</b> 9.012																	5 <b>B</b> 10.81	6 <b>C</b> 12.01	7 <b>N</b> 14.01	8 <b>O</b> 16.00	9 <b>F</b> 19.00	10 <b>Ne</b> 20.18																						
11 <b>Na</b> 22.99	12 <b>Mg</b> 24.31																	13 <b>Al</b> 26.98	14 <b>Si</b> 28.09	15 <b>P</b> 30.97	16 <b>S</b> 32.07	17 <b>Cl</b> 35.45	18 <b>Ar</b> 39.95																						
19 <b>K</b> 39.10	20 <b>Ca</b> 40.08	21 <b>Sc</b> 44.96	22 <b>Ti</b> 47.88	23 <b>V</b> 50.94	24 <b>Cr</b> 52.00	25 <b>Mn</b> 54.94	26 <b>Fe</b> 55.85	27 <b>Co</b> 58.47	28 <b>Ni</b> 58.69	29 <b>Cu</b> 63.55	30 <b>Zn</b> 65.39	31 <b>Ga</b> 69.72	32 <b>Ge</b> 72.59	33 <b>As</b> 74.92	34 <b>Se</b> 78.96	35 <b>Br</b> 79.90	36 <b>Kr</b> 83.80																												
37 <b>Rb</b> 85.47	38 <b>Sr</b> 87.62	39 <b>Y</b> 88.91	40 <b>Zr</b> 91.22	41 <b>Nb</b> 92.91	42 <b>Mo</b> 95.94	43 <b>Tc</b> (98)	44 <b>Ru</b> 101.1	45 <b>Rh</b> 102.9	46 <b>Pd</b> 106.4	47 <b>Ag</b> 107.9	48 <b>Cd</b> 112.4	49 <b>In</b> 114.8	50 <b>Sn</b> 118.7	51 <b>Sb</b> 121.8	52 <b>Te</b> 127.6	53 <b>I</b> 126.9	54 <b>Xe</b> 131.3																												
55 <b>Cs</b> 132.9	56 <b>Ba</b> 137.3	57 <b>La*</b> 138.9	72 <b>Hf</b> 178.5	73 <b>Ta</b> 180.9	74 <b>W</b> 183.9	75 <b>Re</b> 186.2	76 <b>Os</b> 190.2	77 <b>Ir</b> 190.2	78 <b>Pt</b> 195.1	79 <b>Au</b> 197.0	80 <b>Hg</b> 200.5	81 <b>Tl</b> 204.4	82 <b>Pb</b> 207.2	83 <b>Bi</b> 209.0	84 <b>Po</b> (210)	85 <b>At</b> (210)	86 <b>Rn</b> (222)																												
87 <b>Fr</b> (223)	88 <b>Ra</b> (226)	89 <b>Ac~</b> (227)	104 <b>Rf</b> (257)	105 <b>Db</b> (260)	106 <b>Sg</b> (263)	107 <b>Bh</b> (262)	108 <b>Hs</b> (265)	109 <b>Mt</b> (266)	110 --- ( )	111 --- ( )	112 --- ( )	114 --- ( )	116 --- ( )	118 --- ( )																															
<table border="1"> <tbody> <tr> <td>58 <b>Ce</b> 140.1</td> <td>59 <b>Pr</b> 140.9</td> <td>60 <b>Nd</b> 144.2</td> <td>61 <b>Pm</b> (147)</td> <td>62 <b>Sm</b> 150.4</td> <td>63 <b>Eu</b> 152.0</td> <td>64 <b>Gd</b> 157.3</td> <td>65 <b>Tb</b> 158.9</td> <td>66 <b>Dy</b> 162.5</td> <td>67 <b>Ho</b> 164.9</td> <td>68 <b>Er</b> 167.3</td> <td>69 <b>Tm</b> 168.9</td> <td>70 <b>Yb</b> 173.0</td> <td>71 <b>Lu</b> 175.0</td> </tr> <tr> <td>90 <b>Th</b> 232.0</td> <td>91 <b>Pa</b> (231)</td> <td>92 <b>U</b> (238)</td> <td>93 <b>Np</b> (237)</td> <td>94 <b>Pu</b> (242)</td> <td>95 <b>Am</b> (243)</td> <td>96 <b>Cm</b> (247)</td> <td>97 <b>Bk</b> (247)</td> <td>98 <b>Cf</b> (249)</td> <td>99 <b>Es</b> (254)</td> <td>100 <b>Fm</b> (253)</td> <td>101 <b>Md</b> (256)</td> <td>102 <b>No</b> (254)</td> <td>103 <b>Lr</b> (257)</td> </tr> </tbody> </table>																		58 <b>Ce</b> 140.1	59 <b>Pr</b> 140.9	60 <b>Nd</b> 144.2	61 <b>Pm</b> (147)	62 <b>Sm</b> 150.4	63 <b>Eu</b> 152.0	64 <b>Gd</b> 157.3	65 <b>Tb</b> 158.9	66 <b>Dy</b> 162.5	67 <b>Ho</b> 164.9	68 <b>Er</b> 167.3	69 <b>Tm</b> 168.9	70 <b>Yb</b> 173.0	71 <b>Lu</b> 175.0	90 <b>Th</b> 232.0	91 <b>Pa</b> (231)	92 <b>U</b> (238)	93 <b>Np</b> (237)	94 <b>Pu</b> (242)	95 <b>Am</b> (243)	96 <b>Cm</b> (247)	97 <b>Bk</b> (247)	98 <b>Cf</b> (249)	99 <b>Es</b> (254)	100 <b>Fm</b> (253)	101 <b>Md</b> (256)	102 <b>No</b> (254)	103 <b>Lr</b> (257)
58 <b>Ce</b> 140.1	59 <b>Pr</b> 140.9	60 <b>Nd</b> 144.2	61 <b>Pm</b> (147)	62 <b>Sm</b> 150.4	63 <b>Eu</b> 152.0	64 <b>Gd</b> 157.3	65 <b>Tb</b> 158.9	66 <b>Dy</b> 162.5	67 <b>Ho</b> 164.9	68 <b>Er</b> 167.3	69 <b>Tm</b> 168.9	70 <b>Yb</b> 173.0	71 <b>Lu</b> 175.0																																
90 <b>Th</b> 232.0	91 <b>Pa</b> (231)	92 <b>U</b> (238)	93 <b>Np</b> (237)	94 <b>Pu</b> (242)	95 <b>Am</b> (243)	96 <b>Cm</b> (247)	97 <b>Bk</b> (247)	98 <b>Cf</b> (249)	99 <b>Es</b> (254)	100 <b>Fm</b> (253)	101 <b>Md</b> (256)	102 <b>No</b> (254)	103 <b>Lr</b> (257)																																

#### Template

Atomic Number
Atomic Symbol
Atomic Mass

Figure A-2 Simplified Periodic Table

*Note:* From "Los Alamos National Laboratory's Chemistry Division Presents", 2004, *Periodic Table of the Elements: A Resource for Elementary, Middle School, and High School Students*. Retrieved February 11, 2009, from <http://periodic.lanl.gov/default.htm>



## Energy

**Scientists**

---

**Nationality**

---

---

---

**Concept**

---

**Experiment**

---

---

---

**Time Period**

---

**Challenges Faced**

---

---

---

**Mass**

**Scientists**

---

**Nationality**

---

---

---

**Concept**

---

**Experiment**

---

---

---

**Time Period**

---

**Challenges Faced**

---

---

---

## Light

**Scientists**

---

**Nationality**

---

---

---

**Concept**

---

**Experiment**

---

---

---

**Time Period**

---

**Challenges Faced**

---

---

---

## Velocity (Speed of Light Squared)

**Scientists**

---

**Nationality**

---

---

---

**Concept**

---

**Experiment**

---

---

---

**Time Period**

---

**Challenges Faced**

---

---

---

## Development of the Equation $E=mc^2$

**Scientists**

---

**Nationality**

---

---

---

**Concept**

---

**Experiment**

---

---

---

**Time Period**

---

**Challenges Faced**

---

---

---

## Confirmation of the Equation $E=mc^2$

**Scientists**

---

**Nationality**

---

---

---

**Concept**

---

**Experiment**

---

---

---

**Time Period**

---

**Challenges Faced**

---

---

---

## Energy

### Scientist

Michael Faraday.

### Nationality

English.

### Concept

Invisible lines of force flow around electricity and magnets; electricity and magnetism are linked.

### Experiment

Faraday placed a magnet beside a copper wire suspended in mercury and passed an electric current through the wire. The wire spun in a circle around the magnet, thus demonstrating the interaction of lines of electric and magnetic force.

### Time Period

Early 1800s.

### Challenges Faced

Accused of plagiarism by Sir Humphry Davy; refuted claim and was later elected to the Royal Society.

## **Mass**

### **Scientists**

Antoine-Laurent and Marie Anne Lavoisier.

### **Nationality**

French.

### **Concept**

Matter is always conserved in a chemical reaction regardless of how it is transformed.

### **Experiment**

Lavoisier transformed a number of different substances. He carefully measured all the products of the reactions to show that matter is conserved.

### **Time Period**

Late 1700s.

### **Challenges Faced**

The French Revolution; Antoine-Laurent Lavoisier was captured and executed by guillotine.



## Light

### Scientists

Michael Faraday and James Clerk Maxwell.

### Nationality

English (Faraday) and Scottish (Maxwell).

### Concept

Electromagnetism can be described mathematically; Maxwell's equations supported Faraday's long-held claims that light was just one form of electromagnetism.

### Experiment

Maxwell's ideas were theoretical.

### Time Period

Mid-1800s.

### Challenges Faced

Scientists did not agree with Faraday's belief that light was an electromagnetic wave.

## **Velocity (Speed of Light Squared)**

### **Scientists**

Emilie du Châtelet and Gottfried von Leibniz.

### **Nationality**

French (du Châtelet) and German (Leibniz).

### **Concept**

The energy of an object is a function of the square of its speed, rather than its speed.

### **Experiment**

Du Châtelet analyzed experiments in which brass balls were dropped into clay; measuring their impacts demonstrated that an object's energy is a function of its velocity squared. She corrected Newton and clarified Leibniz's original ideas about velocity.

### **Time Period**

Early to mid-1700s.

### **Challenges Faced**

Scientists discounted Leibniz' ideas; du Châtelet died during childbirth when she was 43.

## Development of the Equation $E=mc^2$

### Scientist

Albert Einstein.

### Nationality

German, Swiss, and American.

### Concept

Mass and energy are the same and can be converted from one to the other using the speed of light squared.

### Experiment

Einstein's ideas were theoretical.

### Time Period

Early 1900s.

### Challenges Faced

At first no one responded to Einstein's ideas; he patiently answered letters for four years. His genius began to be recognized when his work gained the endorsement of German physicist Max Planck.

## Confirmation of the Equation $E=mc^2$

### Scientists

Otto Hahn, Fritz Strassmann, Lise Meitner, and Otto Robert Frisch.

### Nationality

German (Hahn, Strassmann) and Austrian (Meitner, Frisch).

### Concept

The confirmation of  $E=mc^2$ .

### Experiment

Hahn and Strassmann bombarded uranium with neutrons and discovered barium in the resulting products; Meitner and Frisch realized the results indicated that Hahn and Strassmann had split the uranium nucleus.

### Time Period

Mid-1900s.

### Challenges Faced

Since she was Jewish, Meitner was forced to flee Germany and compelled to collaborate by mail with Hahn and Strassmann, but Hahn never acknowledged Meitner's work.



**ROYAL CANADIAN AIR CADETS**  
**PROFICIENCY LEVEL FOUR**  
**INSTRUCTIONAL GUIDE**



**SECTION 1**

**EO C460.01 – DESCRIBE AERODROME OPERATIONS CAREER OPPORTUNITIES**

---

Total Time:	30 min
-------------	--------

---

**PREPARATION**

---

**PRE-LESSON INSTRUCTIONS**

Resources needed for the delivery of this lesson are listed in the lesson specification located in A-CR-CCP-804/PG-001, *Proficiency Level Four Qualification Standard and Plan*, Chapter 4. Specific uses for said resources are identified throughout the instructional guide within the TP for which they are required.

Review the lesson content and become familiar with the material prior to delivering the lesson.

**PRE-LESSON ASSIGNMENT**

Nil.

**APPROACH**

An in-class activity was chosen for TP 1 as it is an interactive way to provoke thought and stimulate interest among cadets.

A group discussion was chosen for TP 2 as it allows the cadets to interact with their peers and share their knowledge, experiences, opinions, and feelings on aerodrome operations career opportunities.

---

**INTRODUCTION**

---

**REVIEW**

Nil.

**OBJECTIVES**

By the end of this lesson the cadet shall be expected to describe aerodrome operations career opportunities.

**IMPORTANCE**

It is important for cadets to describe aerodrome operations career opportunities as there are a wide variety of careers available in this field. An ability to describe these career opportunities is an important step in the process of preparing cadets for aviation-related careers.

---

**Teaching Point 1**

**Have the cadets brainstorm aerodrome operations career opportunities.**

Time: 10 min

Method: In-Class Activity

---

**ACTIVITY**

**OBJECTIVE**

The objective of this activity is to have the cadets brainstorm a list of aerodrome operations career opportunities.

**RESOURCES**

- Flip chart paper, and
- Markers.

**ACTIVITY LAYOUT**

Nil.

**ACTIVITY INSTRUCTIONS**

1. Divide the cadets into groups of no more than three.
2. Distribute a piece of flip chart paper and a marker to each group.
3. Have each group brainstorm a list of aerodrome operations career opportunities.
4. Have each group present their list to the class.



Encourage the cadets to consider career opportunities at various types of airports (eg, private, municipal, regional, national, international).

**SAFETY**

Nil.

---

**CONFIRMATION OF TEACHING POINT 1**

The cadets' participation in the activity will serve as the confirmation of this TP.

---

**Teaching Point 2****Conduct a group discussion on aerodrome operations career opportunities.**

Time: 15 min

Method: Group Discussion

---

---

**BACKGROUND KNOWLEDGE**

---



The purpose of the group discussion is to draw the following information from the group using the tips for answering / facilitating discussion and the suggested questions provided.

**AERODROME OPERATIONS CAREER OPPORTUNITIES****Aerodrome Operations Careers**

The career opportunities at aerodromes vary widely, depending on the type of aerodrome. At a small aerodrome, there are fewer positions available, but these positions require an extensive set of skills. Typical positions at a small aerodrome might include:

- aerodrome manager,
- equipment operator, and
- ramp attendant.

It is not uncommon at a small aerodrome for one person to be required to fulfill multiple roles (eg, the manager may also have to operate the equipment and refuel aircraft).

At a large aerodrome, there are more positions available and these positions are more specialized. Additionally, very large aerodromes can be compared to a small city. Typical positions at a large aerodrome might include:

- manager of airside operations,
- manager of groundside operations,
- personnel manager,
- cargo handler,
- refuelling specialist,
- various accounting and administrative positions,
- safety inspectors,
- terminal concession operators,
- building maintenance personnel,
- vehicle maintenance personnel, and
- electrical / mechanical maintenance personnel.

## **Skills and Training Required**

The skills and training required for a career in aerodrome operations will vary depending on the specific career desired and the type of aerodrome. Some of the skills and training that might be required include:

- aviation knowledge, such as:
  - principles of flight,
  - meteorology,
  - air law,
  - navigation, and
  - airmanship;
- radio communications procedures,
- equipment operation (eg, tractors, mowers, trucks, specialty vehicles),
- safety training, such as:
  - first aid,
  - hazardous material handling, and
  - safety reporting and auditing;
- knowledge of management / leadership principles,
- knowledge of marketing concepts,
- knowledge of accounting principles,
- mechanical / technical skills,
- customer service skills,
- aircraft recognition skills, and
- communication (written and verbal) skills.

## **Training Institutions**

There are several well-known post-secondary programs in Canada that specialize in aerodrome operations.

The British Columbia Institute of Technology (BCIT) School of Transportation offers a diploma of Technical Studies in Airport Operations at its Aerospace Technology Campus in Kelowna, B.C.

Georgian College in Barrie, Ont., offers a three-year diploma in Aviation Management that includes co-operative work experience.

The University of Western Ontario, in London, Ont., offers a Bachelor of Administrative and Commercial Studies, Commercial Aviation Management Degree that combines a Commercial Pilot Licence with extensive study in business administration and aviation subjects.



---

## GROUP DISCUSSION

---



### TIPS FOR ANSWERING / FACILITATING DISCUSSION:

- Establish ground rules for discussion, eg, everyone should listen respectfully; don't interrupt; only one person speaks at a time; no one's ideas should be made fun of; you can disagree with ideas but not with the person; try to understand others as much as you hope they understand you; etc.
- Sit the group in a circle, making sure all cadets can be seen by everyone else.
- Ask questions that will provoke thought; in other words avoid questions with yes or no answers.
- Manage time by ensuring the cadets stay on topic.
- Listen and respond in a way that indicates you have heard and understood the cadet. This can be done by paraphrasing their ideas.
- Give the cadets time to respond to your questions.
- Ensure every cadet has an opportunity to participate. One option is to go around the group and have each cadet answer the question with a short answer. Cadets must also have the option to pass if they wish.
- Additional questions should be prepared ahead of time.

### SUGGESTED QUESTIONS:

- Q1. What type of skills would the manager of a small aerodrome need?
- Q2. What type of skills would the manager of a large aerodrome need?
- Q3. What type of skills and training would be common to any career at any size aerodrome?
- Q4. What aviation-specific knowledge would be needed to work at an aerodrome?
- Q5. Why would knowledge of meteorology be important for someone working at an aerodrome?
- Q6. Why would knowledge of radio communication procedures be important for someone working at an aerodrome?
- Q7. Which employees at an aerodrome would need to understand accounting? Why?
- Q8. Why would an airport manager need to be able to communicate using written methods of communication?
- Q9. Which post-secondary training institutions offer specialized aerodrome operations programs?
- Q10. Which type of university degrees would be helpful to someone looking for a career in aerodrome operations?



Other questions and answers will develop throughout the group discussion. The group discussion should not be limited to only those suggested.



Reinforce those answers given and comments made during the group discussion, ensuring the teaching points have been covered.

---

### **CONFIRMATION OF TEACHING POINT 2**

The cadets' participation in the group discussion will serve as the confirmation of this TP.

---

### **END OF LESSON CONFIRMATION**

The cadets' participation in the group discussion on aerodrome operations career opportunities will serve as the confirmation of this lesson.

---

### **CONCLUSION**

---

### **HOMEWORK / READING / PRACTICE**

Nil.

### **METHOD OF EVALUATION**

Nil.

### **CLOSING STATEMENT**

A wide variety of career opportunities exist in the aerodrome operations field. Part of the process of preparing for a career in this field is to describe the career opportunities. By describing the opportunities and discussing the skills, required training, and training institutes you may be able to decide if one of these careers is the one for you.

### **INSTRUCTOR NOTES / REMARKS**

If available, a guest speaker from the field of aerodrome operations may be used for this lesson.

---

### **REFERENCES**

C3-309 Avjobs.com. (2009). *Aviation career overviews*. Retrieved February 9, 2009, from <http://www.avjobs.com/careers/index.asp>

C3-313 Canadian Airports Council. (2009). *Post secondary programs*. Retrieved February 9, 2009, from [http://www.cacairports.ca/english/careers/post\\_secondary\\_programs.php](http://www.cacairports.ca/english/careers/post_secondary_programs.php)



**ROYAL CANADIAN AIR CADETS**  
**PROFICIENCY LEVEL FOUR**  
**INSTRUCTIONAL GUIDE**



**SECTION 2**

**EO C460.02 – DESCRIBE AIR TRAFFIC CONTROL (ATC) CAREER OPPORTUNITIES**

---

Total Time: 30 min

---

**PREPARATION**

---

**PRE-LESSON INSTRUCTIONS**

Resources needed for the delivery of this lesson are listed in the lesson specification located in A-CR-CCP-804/PG-001, *Proficiency Level Four Qualification Standard and Plan*, Chapter 4. Specific uses for said resources are identified throughout the instructional guide within the TP for which they are required.

Review the lesson content and become familiar with the material prior to delivering the lesson.

**PRE-LESSON ASSIGNMENT**

Have the cadets visit the NAV CANADA ATC careers web site (<http://takecharge.navcanada.ca>) or provide handouts of the content on the web site at least one week prior to the lesson.

**APPROACH**

An in-class activity was chosen for TP 1 as it is an interactive way to provoke thought and stimulate interest in ATC career opportunities among cadets.

A group discussion was chosen for TP 2 as it allows the cadets to interact with their peers and share their knowledge, opinions and feelings about ATC career opportunities.

---

**INTRODUCTION**

---

**REVIEW**

Nil.

**OBJECTIVES**

By the end of this lesson the cadet shall be expected to describe ATC career opportunities.

**IMPORTANCE**

It is important for cadets to describe ATC career opportunities as ATC is responsible for the safe and efficient flow of air traffic. An ability to describe these career opportunities is an important step in the process of preparing cadets for aviation-related careers.

---

**Teaching Point 1**

**Have the cadets brainstorm ATC career opportunities.**

Time: 10 min

Method: In-Class Activity

---

**ACTIVITY**

**OBJECTIVE**

The objective of this activity is to have the cadets brainstorm a list of ATC career opportunities.

**RESOURCES**

- Flip chart paper, and
- Markers.

**ACTIVITY LAYOUT**

Nil.

**ACTIVITY INSTRUCTIONS**

1. Divide the cadets into groups of no more than three.
2. Distribute a piece of flip chart paper and a marker to each group.
3. Have each group brainstorm a list of ATC career opportunities.
4. Have each group present their list to the class.



Encourage the cadets to consider ATC career opportunities at various types of airports (eg, private, municipal, regional, national, international).

**SAFETY**

Nil.

---

**CONFIRMATION OF TEACHING POINT 1**

The cadets' participation in the activity will serve as the confirmation of this TP.

**Teaching Point 2****Conduct a group discussion on ATC career opportunities.**

Time: 15 min

Method: Group Discussion

**BACKGROUND KNOWLEDGE**

The purpose of the group discussion is to draw the following information from the group using the tips for answering / facilitating discussion and the suggested questions provided.

**ATC CAREER OPPORTUNITIES**

ATC in Canada is provided by a private, not for profit company called NAV CANADA. NAV CANADA is responsible for the selection and training processes. Transport Canada is responsible for setting the prerequisites for candidates and the ensuring that the candidates meet the required standards prior to issuing an ATC license.

**ATC Careers**

There are three main career opportunities in the ATC field:

- flight service specialist,
- instrument flight rules (IFR) air traffic controller, and
- visual flight rules (VFR) air traffic controller.

As a person gains experience in their chosen option, additional opportunities become available (eg, supervisory and management opportunities).



Additional career opportunities exist outside of ATC within NAV CANADA. A list of current opportunities can be view at the NAV CANADA web site (<http://www.navcanada.ca>) in the Careers section.

**Selection Requirements**

Previous aviation-related experience and knowledge is not required to be selected for ATC training. The aviation knowledge required is part of the training. In order to be selected for ATC training, all candidates must be:

- at least 18 years old,
- a Canadian citizen (or permanent resident),
- a high school graduate,
- available for training within the next 18 months,
- willing to relocate,
- willing to undergo a medical exam,
- prepared to undergo a security check (secret level),

- willing to train intensively, and
- English-speaking or fluently bilingual (English and French).

### **Selection Process**

The selection process is designed to select the best applicants who have:

- sharp judgment,
- strong motivation,
- excellent problem-solving abilities,
- a clear voice, and
- a good memory.

There are six steps in the selection process. The first step is to apply online (<http://takecharge.navcanada.ca>). After completing the application process, there are two online tests that must be taken. If the results from the online tests are favourable, the applicant will be contacted by NAV CANADA and invited to participate in an in-person assessment session. A \$200 assessment fee is charged for the in-person session. The testing during this session is more extensive and includes a variety of tests that measure:

- thinking and reasoning,
- communication,
- multi-tasking,
- attention,
- information processing,
- memory,
- motor ability,
- agreeableness,
- conscientiousness,
- emotional stability, and
- knowledge.

The most successful candidates from the in-person assessment sessions are invited to participate in a two-stage interview process. The first interview is conducted during a teleconference, and the second interview is conducted in person. Successful candidates from the interview process are placed on a roster for training. Candidates placed on the roster for training must undergo a medical exam and a security check. Following the medical exam and security check, candidates must then complete a 30–50 hour Introduction to Aviation online course prior to commencing the formal training process.

### **Training Process**

The initial classroom training process for all three specialties is conducted at seven area control centres (ACCs). Candidates will be trained initially in the same area of the country that their on-the-job training (OJT) phase will be conducted.

Flight service specialists receive initial training of up to six months. The tuition for this phase is \$1 000. Upon completion of initial training, candidates move to the OJT phase and begin earning a training salary (approximately \$30 000 per year). OJT may last up to six months.

VFR air traffic controllers receive initial training of four to six months in duration. The tuition for this phase is \$2 500. Upon completion of initial training, candidates move to the OJT phase and begin earning a training salary (approximately \$33 000 per year). OJT will last for four to six months.

IFR air traffic controllers receive initial training of 7–14 months in duration. The tuition for this phase is \$3 500. Upon completion of initial training, candidates move to the OJT phase and begin earning a training salary (approximately \$33 000 per year). OJT will last for 6–12 months.



The assessment fee, tuition costs and training salaries are current as of April 2009.

---

## GROUP DISCUSSION

---



### TIPS FOR ANSWERING / FACILITATING DISCUSSION:

- Establish ground rules for discussion, eg, everyone should listen respectfully; don't interrupt; only one person speaks at a time; no one's ideas should be made fun of; you can disagree with ideas but not with the person; try to understand others as much as you hope they understand you; etc.
- Sit the group in a circle, making sure all cadets can be seen by everyone else.
- Ask questions that will provoke thought; in other words avoid questions with yes or no answers.
- Manage time by ensuring the cadets stay on topic.
- Listen and respond in a way that indicates you have heard and understood the cadet. This can be done by paraphrasing their ideas.
- Give the cadets time to respond to your questions.
- Ensure every cadet has an opportunity to participate. One option is to go around the group and have each cadet answer the question with a short answer. Cadets must also have the option to pass if they wish.
- Additional questions should be prepared ahead of time.

### SUGGESTED QUESTIONS:

- Q1. What type of skills would a flight service specialist need?
- Q2. What type of skills would a VFR air traffic controller need?
- Q3. What type of skills would a IFR air traffic controller need?
- Q4. What aviation-specific knowledge would be needed for a career in ATC?

- Q5. Why would knowledge of meteorology be important for someone in a career in ATC?
- Q6. Why would knowledge of radio communication procedures be important for a career in ATC?
- Q7. What are the prerequisites for a career in ATC?
- Q8. What is the selection process for a career in ATC?
- Q9. What is the training process for a career in ATC?
- Q10. What type of post-secondary training would be helpful to someone looking for a career in ATC?



Other questions and answers will develop throughout the group discussion. The group discussion should not be limited to only those suggested.



Reinforce those answers given and comments made during the group discussion, ensuring the teaching points have been covered.

---

### **CONFIRMATION OF TEACHING POINT 2**

The cadets' participation in the group discussion will serve as the confirmation of this TP.

---

### **END OF LESSON CONFIRMATION**

The cadets' participation in the group discussion on ATC career opportunities will serve as the confirmation of this lesson.

---

### **CONCLUSION**

---

### **HOMEWORK / READING / PRACTICE**

Nil.

### **METHOD OF EVALUATION**

Nil.

### **CLOSING STATEMENT**

A variety of career opportunities exist in the ATC field. Part of the process of preparing for a career in this field is to describe the career opportunities. By describing the opportunities and discussing the skills, required training, and training institutes you may be able to decide if one of these careers is the one for you.

### **INSTRUCTOR NOTES / REMARKS**

If available, a guest speaker from the field of air traffic control may be used for this lesson.



---

**REFERENCES**

---

C3-332 NAV CANADA. (2009). *Take charge of your career*. Retrieved February 23, 2009, from <http://takecharge.navcanda.ca>

THIS PAGE INTENTIONALLY LEFT BLANK



**ROYAL CANADIAN AIR CADETS  
PROFICIENCY LEVEL FOUR  
INSTRUCTIONAL GUIDE**



**SECTION 3**

**EO C460.03 – DESCRIBE AIRPORT SECURITY CAREER OPPORTUNITIES**

---

Total Time:	30 min
-------------	--------

---

**PREPARATION**

---

**PRE-LESSON INSTRUCTIONS**

Resources needed for the delivery of this lesson are listed in the lesson specification located in A-CR-CCP-804/PG-001, *Proficiency Level Four Qualification Standard and Plan*, Chapter 4. Specific uses for said resources are identified throughout the instructional guide within the TP for which they are required.

Review the lesson content and become familiar with the material prior to delivering the lesson.

**PRE-LESSON ASSIGNMENT**

Have the cadets visit the Canadian Air Transport Security Authority (CATSA) web site (<http://www.catsa-acsta.gc.ca>) or provide handouts of the roles and responsibilities, and career opportunities sections of the web site at least one week prior to the lesson.

**APPROACH**

An in-class activity was chosen for TP 1 as it is an interactive way to provoke thought and stimulate interest among cadets.

A group discussion was chosen for TP 2 as it allows the cadets to interact with their peers and share their knowledge, experiences, opinions, and feelings on airport security career opportunities.

---

**INTRODUCTION**

---

**REVIEW**

Nil.

**OBJECTIVES**

By the end of this lesson the cadet shall be expected to describe airport security career opportunities.

**IMPORTANCE**

It is important for cadets to describe airport security career opportunities as airport security is an important and growing responsibility at airports. An ability to describe these career opportunities is an important step in the process of preparing cadets for aviation-related careers.

---

**Teaching Point 1**

**Have the cadets brainstorm airport security career opportunities.**

Time: 10 min

Method: In-Class Activity

---

**ACTIVITY**

**OBJECTIVE**

The objective of this activity is to have the cadets brainstorm a list of airport security career opportunities.

**RESOURCES**

- Flip chart paper, and
- Markers.

**ACTIVITY LAYOUT**

Nil.

**ACTIVITY INSTRUCTIONS**

1. Divide the cadets into groups of no more than three.
2. Distribute a piece of flip chart paper and a marker to each group.
3. Have each group brainstorm a list of airport security career opportunities.
4. Have each group present their list to the class.



Encourage the cadets to consider airport security career opportunities at various types of airports (eg, private, municipal, regional, national, international).

**SAFETY**

Nil.

---

**CONFIRMATION OF TEACHING POINT 1**

The cadets' participation in the activity will serve as the confirmation of this TP.

**Teaching Point 2****Conduct a group discussion on airport security career opportunities.**

Time: 15 min

Method: Group Discussion

**BACKGROUND KNOWLEDGE**

The purpose of the group discussion is to draw the following information from the group using the tips for answering / facilitating discussion and the suggested questions provided.

**AIRPORT SECURITY CAREER OPPORTUNITIES**

Security at an airport is provided by a number of different agencies, each with specific areas of responsibilities and unique career opportunities within their areas of responsibilities.

**Canadian Air Transport Security Authority (CATSA)**

CATSA is responsible for the following areas:

- ensuring screening of passengers and non-passengers is conducted IAW regulations at major airports;
- acquiring, deploying, operating, inspecting, and maintaining explosive detection systems at designated airports;
- implementing a restricted area identification card system at major airports; and
- developing, implementing, and evaluating a training and certification program for screening officers.

**Screening Contractors**

Pre-board screening personnel are provided by security firms contracted by CATSA. A variety of firms across the country provide these services.

**Screening Equipment Maintenance Contractors**

These contractors are responsible for maintaining the screening and security equipment IAW applicable contracts and regulations. This includes calibration of equipment and documentation of maintenance and outages.

**Air Carriers**

Air carriers (eg, airlines) are responsible for the security of their operations, the security of baggage after it has been screened, and ensuring that dangerous goods are transported IAW applicable regulations.

**Airport Operators**

Airport operators are responsible for providing physical security measures for the airport facility, providing space for screening operations, and maintaining the restricted area identification card system.

**Jurisdictional Police**

The jurisdictional police force is responsible for responding to emergency and security-related incidents at the airport.

## Transport Canada

Transport Canada is responsible for developing regulations and standards for airport security, granting security clearances as part of the restricted area identification card system, and auditing / inspecting the security operations at airports.

### SKILLS AND TRAINING REQUIRED

The required skills and training vary widely depending on the specific career in airport security. The requirements common to most of the available careers in airport security are:

- being a Canadian resident for at least the last five years,
- being able to obtain a Transport Canada security clearance,
- being at least 18 years old,
- being a high school graduate,
- having excellent customer service skills,
- being able to handle stress, and
- being able to function autonomously.

### TRAINING INSTITUTIONS

Career-specific training is usually handled directly by the employer, but any security-related post-secondary program is generally considered helpful to those looking for employment in the field of airport security. Many aviation programs (eg, aviation management and commercial pilot) also include a component on airport security.

---

## GROUP DISCUSSION

---



### TIPS FOR ANSWERING / FACILITATING DISCUSSION:

- Establish ground rules for discussion, eg, everyone should listen respectfully; don't interrupt; only one person speaks at a time; no one's ideas should be made fun of; you can disagree with ideas but not with the person; try to understand others as much as you hope they understand you; etc.
- Sit the group in a circle, making sure all cadets can be seen by everyone else.
- Ask questions that will provoke thought; in other words avoid questions with yes or no answers.
- Manage time by ensuring the cadets stay on topic.
- Listen and respond in a way that indicates you have heard and understood the cadet. This can be done by paraphrasing their ideas.
- Give the cadets time to respond to your questions.

- Ensure every cadet has an opportunity to participate. One option is to go around the group and have each cadet answer the question with a short answer. Cadets must also have the option to pass if they wish.
- Additional questions should be prepared ahead of time.

### **SUGGESTED QUESTIONS:**

- Q1. What types of skills would a pre-board screening officer need?
- Q2. What types of skills and training would be common to any career in airport security?
- Q3. What aviation-specific knowledge would be needed to work in airport security?
- Q4. Why would knowledge of radio communication procedures be important for someone working in airport security?
- Q5. Which type of post-secondary training would be helpful to someone looking for a career in airport security?



Other questions and answers will develop throughout the group discussion. The group discussion should not be limited to only those suggested.



Reinforce those answers given and comments made during the group discussion, ensuring the teaching points have been covered.

---

### **CONFIRMATION OF TEACHING POINT 2**

The cadets' participation in the group discussion will serve as the confirmation of this TP.

---

### **END OF LESSON CONFIRMATION**

The cadets' participation in the group discussion on airport security career opportunities will serve as the confirmation of this lesson.

---

### **CONCLUSION**

---

#### **HOMEWORK / READING / PRACTICE**

Nil.

#### **METHOD OF EVALUATION**

Nil.

## **CLOSING STATEMENT**

A wide variety of career opportunities exist in the airport security field. Part of the process of preparing for a career in this field is to describe the career opportunities. By describing the opportunities and discussing the skills, required training, and training institutes you may be able to decide if one of these careers is the one for you.

## **INSTRUCTOR NOTES / REMARKS**

If available, a guest speaker from the field of airport security may be used for this lesson.

---

## **REFERENCES**

---

C3-309 Avjobs.com. (2009). *Aviation career overviews*. Retrieved February 9, 2009, from <http://www.avjobs.com/careers/index.asp>

C3-316 Canadian Air Transport Security Authority. (2008). *Screening officers – Roles and responsibilities*. Retrieved February 10, 2009, from <http://www.catsa-acsta.gc.ca/so-ac/english/roles/>

C3-317 Canadian Air Transport Security Authority. (2009). *Employment opportunities*. Retrieved February 10, 2009, from [http://www.catsa-acsta.gc.ca/english/about\\_propos/opp/index.cfm](http://www.catsa-acsta.gc.ca/english/about_propos/opp/index.cfm)





**ROYAL CANADIAN AIR CADETS**  
**PROFICIENCY LEVEL FOUR**  
**INSTRUCTIONAL GUIDE**



**SECTION 1**

**EO C470.01 – DISCUSS AIRCRAFT MANUFACTURERS**

---

Total Time:	30 min
-------------	--------

---

**PREPARATION**

---

**PRE-LESSON INSTRUCTIONS**

Resources needed for the delivery of this lesson are listed in the lesson specification located in A-CR-CCP-804/PG-001, *Proficiency Level Four Qualification Standard and Plan*, Chapter 4. Specific uses for said resources are identified throughout the instructional guide within the TP for which they are required.

Review the lesson content and become familiar with the material prior to delivering the lesson.

Prepare the list of international partnerships located at Attachment A by photocopying the list and cutting the sections apart to distribute to the cadets.

Photocopy the International Partnership Summary Sheet located at Attachment B for each cadet.

Photocopy the Unmanned Aerial Vehicle (UAV) Manufacturers Worksheet located at Attachment C for each cadet.

UAVs are continuously changing. The information presented in Reference C3-324 may be used as a starting point in researching current UAVs and UAV manufacturers. Research current UAVs and UAV manufacturers and collect information on two or three UAVs from newspapers, magazines, journals or websites to present in TP 2. The *Aircraft* page on the Air Force website (<http://www.airforce.gc.ca>) may include information on UAVs used by the Canadian Forces.

**PRE-LESSON ASSIGNMENT**

At least one week before the lesson, assign each cadet (or have each cadet select) an international partnership from the list of international partnerships located at Attachment A. Distribute an International Partnership Summary Sheet located at Attachment B to each cadet. Have the cadets review and research the international partnership details and prepare a short oral presentation (approximately 2–5 minutes) using the International Partnership Summary Sheet located at Attachment B.

**APPROACH**

An in-class activity was chosen for TP 1 as it is an interactive way to provoke thought and stimulate interest among cadets.

An interactive lecture was chosen for TP 2 to identify UAV manufacturers.

---

## INTRODUCTION

---

### REVIEW

Nil.

### OBJECTIVES

By the end of this lesson the cadet shall have discussed international partnerships between aircraft manufacturers and identified UAV manufacturers.

### IMPORTANCE

It is important for cadets to discuss international partnerships between aircraft manufacturers as Canada is a leading exporter of advanced technology and is the fourth largest producer of civil aircraft in the world. It is important for cadets to identify UAV manufacturers as UAVs are a relatively new technology and are rapidly becoming more important in aviation, especially military aviation.

---

**Teaching Point 1**

**Conduct an activity where the cadets will review a summary of an international partnership between aircraft manufacturers and make a short oral presentation on the international partnership.**

Time: 20 min

Method: In-Class Activity

---

**ACTIVITY****OBJECTIVE**

The objective of this activity is have the cadets review a summary of an international partnership between aircraft manufacturers and make a short oral presentation on the international partnership.

**RESOURCES**

- Pen / pencil,
- List of international partnerships located at Attachment A, and
- International Partnership Summary Sheet located at Attachment B.

**ACTIVITY LAYOUT**

Nil.

**ACTIVITY INSTRUCTIONS**

Have each cadet make a short oral presentation (approximately 2–5 minutes) to the group on their selected / assigned international partnership using the information they have recorded on the International Partnership Summary Sheet.



If there is not enough time for all the cadets to make their presentations, the cadets can be divided into two or more groups.

**SAFETY**Nil.

---

**CONFIRMATION OF TEACHING POINT 1**

The cadets' participation in the activity will serve as the confirmation of this TP.

---

**Teaching Point 2**

**Identify UAV manufacturers.**

Time: 5 min

Method: Interactive Lecture

---



Distribute an Unmanned Aerial Vehicles (UAV) Manufacturers Worksheet located at Attachment C to each cadet.



Present the information collected on the UAVs to the cadets and have the cadets make notes using the Unmanned Aerial Vehicles (UAV) Manufacturers Worksheet.

---

**CONFIRMATION OF TEACHING POINT 2**

The cadets' completion of the Unmanned Aerial Vehicles (UAV) Manufacturers Worksheet will serve as the confirmation of this TP.

---

**END OF LESSON CONFIRMATION**

The cadets' participation in presenting the information on an international manufacturing partnership will serve as the confirmation of this lesson.

---

**CONCLUSION**

---

**HOMEWORK / READING / PRACTICE**

Nil.

**METHOD OF EVALUATION**

Nil.

**CLOSING STATEMENT**

Canada is one of the world's leading suppliers of aviation technology. International partnerships between Canadian aviation manufacturers and those in other countries results in 85 percent of the aviation production being sold internationally. The use of UAVs, especially in military aviation, is growing rapidly and the manufacturing of UAVs is becoming an important sector in aviation manufacturing.

**INSTRUCTOR NOTES / REMARKS**

Cadets who are qualified Advanced Aviation Technology – Aircraft Manufacturing and Maintenance may be able to assist with this lesson.

---

**REFERENCES**

---

- C3-321 ISBN 978-2-921393-91-1 Bombardier Inc. (2009). *Canada's Bombardier*. Canada: Bombardier Inc.
- C3-322 Government of Canada. (2008). *Canada's aerospace advantages*. Retrieved February 10, 2009 from <http://investincanada.gc.ca/eng/industry-sectors/advanced-manufacturing/aerospace/aerospace-advantages.aspx>
- C3-323 Industry Canada. (2009). *Aerospace in Canada*. Retrieved February 10, 2009 from <http://www.ic.gc.ca/eic/site/ad-ad.nsf/eng/ad03909.html>
- C3-324 Thirty Thousand Feet Aviation Directory. (2009). *Unmanned aerial vehicles*. Retrieved February 10, 2009, from <http://www.thirtythousandfeet.com/uav.htm>

THIS PAGE INTENTIONALLY LEFT BLANK

## International Partnerships

After photocopying, cut the list apart on the dotted lines and distribute as required to the cadets.

### Pratt & Whitney Canada

- Pratt & Whitney Canada is an aerospace leader committed to shaping the future of business, general aviation, and regional aircraft and helicopters with high-performing, dependable engines.
- A new 10 000-pound thrust class engine family was selected by Cessna Aircraft for the Citation Columbus business jet and will exceed International Civil Aviation Organization (ICAO) emissions standards by up to 50 percent.

### Bombardier Aerospace

- Bombardier's regional airliner product family includes the CRJ series regional jets and the Q series turboprop.
- Bombardier is the world's third largest civil aircraft manufacturer with locations in 22 countries and customers in more than 100 countries.

### Goodrich and Messier-Dowty

- The landing gear market is the undisputed domain of Canadian industry.
- Goodrich is the chosen supplier of components for the Airbus A380 landing gear. Messier-Dowty supplies landing gear for the Boeing 787.

### ExelTech Aerospace

- ExelTech Aerospace is the largest regional aircraft maintenance, repair, and overhaul (MRO) in North America and services such types as the Bombardier CRJ, Embraer ERJ, ATR-42, ATR-72, Boeing 737, and Saab 340.

### Magellan, Honeywell, and Avcorp

- The Joint Strike Fighter (JSF) program has nine different nations as partners: the United States, the United Kingdom, Italy, the Netherlands, Turkey, Canada, Denmark, Norway, and Australia.
- Several Canadian companies supply components and systems to the JSF including Magellan (primary flight and propulsion structures), Honeywell (power management system), and Avcorp (outboard wings).

.....

### **CAE**

- CAE is a world leader in simulation and training services for civil and military aviation.
- Through its global network of 27 civil and military aviation training centres, CAE trains more than 75 000 crew members annually.

### **Thales**

- Thales is a world leader in mission-critical information systems for aviation, defence, and security markets with operations in 50 countries.
- Their headquarters is in Montreal and it is the worldwide centre of excellence for flight control systems.

### **CMC Electronics**

- CMC Electronics provides innovative cockpit systems integration and avionics to customers worldwide.
- CMC is the prime contractor for the avionics systems integration of the Beechcraft T-6B military trainer aircraft.

### **Magellan Aerospace Corporation**

- Magellan Aerospace Corporation has locations in Canada, the United States, the United Kingdom, and India.
- Magellan designs, manufactures, and repairs aeroengine and aerostructure components and assemblies.

### **Avcorp**

- Avcorp produces high-strength interior panels, fuel tanks, structural wing components, and fully integrated vertical and horizontal stabilizers.
- Avcorp is providing primary flight structures for the Cessna Sovereign and Citation CJ3 business jets.

### **Standard Aero**

- Standard Aero is among the largest small-turbine engine maintenance and repair companies in the world, providing MRO services for General Electric, Rolls-Royce, Honeywell and P&WC engines.



**International Partnership Summary Sheet**

<b>Companies and Countries Involved</b>
<b>Aircraft Types and / or Components Involved</b>
<b>Additional Information</b>

THIS PAGE INTENTIONALLY LEFT BLANK

**Unmanned Aerial Vehicle (UAV) Manufacturers Worksheet**

<b>UAV Name</b>	<b>Manufacturer Name and Country of Manufacture</b>	<b>Purpose(s)</b>

THIS PAGE INTENTIONALLY LEFT BLANK



**ROYAL CANADIAN AIR CADETS  
PROFICIENCY LEVEL FOUR  
INSTRUCTIONAL GUIDE**



**SECTION 2**

**EO C470.02 – DISCUSS AIRCRAFT ASSEMBLY**

---

Total Time:	30 min
-------------	--------

---

**PREPARATION**

---

**PRE-LESSON INSTRUCTIONS**

Resources needed for the delivery of this lesson are listed in the lesson specification located in A-CR-CCP-804/PG-001, *Proficiency Level Four Qualification Standard and Plan*, Chapter 4. Specific uses for said resources are identified throughout the instructional guide within the TP for which they are required.

Review the lesson content and become familiar with the material prior to delivering the lesson.

Create slides of the Figures located at Attachments A and B.

Cue *The World's Biggest Airliner: The Airbus A380* DVD to the first chapter, *Toulouse, France* (seven minutes).

**PRE-LESSON ASSIGNMENT**

Nil.

**APPROACH**

An interactive lecture was chosen for this lesson to introduce aspects of aircraft assembly methods and give an overview of them.

---

**INTRODUCTION**

---

**REVIEW**

Nil.

**OBJECTIVES**

By the end of this lesson the cadet shall have discussed the assembly of aircraft components in a manufacturing setting.

**IMPORTANCE**

It is important for the cadets to learn about aircraft assembly methods because this will enhance their understanding of aircraft and the field of aviation.

---

**Teaching Point 1****Describe different methods of assembly of components.**

Time: 15 min

Method: Interactive Lecture

---

**SMALL MANUFACTURERS**

For an aircraft to fly correctly, the main structural components, such as fuselage, wings, engines and empennage parts must be aligned perfectly. Any deviation or flaw, such as a twist in any component, will impair flight and have a negative effect on flight controls. Cranes hold the heavy parts in place, jigs and templates position them precisely. The development of techniques for measuring and positioning components on the structure to a high degree of accuracy have been developed, as aircraft have become heavier and faster.

**LARGE MANUFACTURERS**

Some aircraft are now so large that cranes cannot lift and hold the parts satisfactorily. Special carriers are custom-built to hold the parts, while computer control is used to bring them together. Lasers measure distances and angles with the use of mirrors, and send the data to high-speed computers. By using these methods, the fuselage, wings and empennage components can be assembled precisely, no matter how large they are.

Not all aircraft components are structural. A company such as Bombardier Aerospace has hundreds of suppliers that provide everything from horizontal stabilizers to airspeed indicators. All of these components fit and work together as a result of a process called Systems Integration. The aerospace engineers designing the aircraft must ensure that physical components and associated software programs work together.



Show the cadets the first chapter *Toulouse France* of *The World's Biggest Airliner: The Airbus A380*. This section covers the use of mirrors and an infrared laser positioning system and shows the fuselage components being joined.

---

**CONFIRMATION OF TEACHING POINT 1****QUESTIONS:**

- Q1. Why must an aircraft's structural components be aligned perfectly?
- Q2. For large aircraft, what type of control is used to bring the structural parts together?
- Q3. What is the name of the process that aeronautical engineers use to integrate separate systems?

**ANTICIPATED ANSWERS:**

- A1. Any deviation or flaw will impair flight and have a negative effect on flight controls.
- A2. Computer control.
- A3. Systems Integration.

**Teaching Point 2****Discuss manufacturers' assembly areas.**

Time: 10 min

Method: Interactive Lecture

**A SMALL MANUFACTURER'S SHOP**

Small manufacturers can often perform all necessary operations in one location like Viking Air, which manufactures the new 400 series Twin Otter and remanufactures Beaver and Otter aircraft near the Victoria International Airport in Sydney, British Columbia. A small manufacturer's shop is characterized by all the aircraft parts and materials coming together at one manufacturing plant prior to final assembly. All necessary machinery and facilities are provided, sometimes under one roof. Manufacturing encompasses all phases of assembly from sheet metal bending, engine assembly, avionics and final painting and interior finish.



Viking Air is considered a small manufacturer's shop. They manufacture, assemble, modify, and repair aircraft.

**A LARGE MANUFACTURER'S ASSEMBLY LINE**

All manufacturers need machines to move large, heavy components such as wings and to control their motion with precision. In the assembly areas of large aircraft, these machines are also large.



Show the cadets the series of assembly area photographs located at Attachment A.



Larger manufacturers generally have more career specialization than smaller ones, such as engine, airframe or avionics specialization. Small manufacturers have fewer employees, so they need their employees to be able to handle more related fields.

Large manufacturers such as Bombardier Aerospace have facilities around the world. The materials and components for the basic aircraft structure are gathered at one assembly plant, such as Downsview in Toronto, Ontario. This plant is responsible for the final assembly of structural components for the Learjet 45 aircraft, the Q-Series turboprops and the Global family of business aircraft. The facility occupies 324 acres of land and has almost two million square feet of building floor space. At Dorval, Quebec, Bombardier has a completion facility with 31 345 square metres (337 400 square feet), housing up to 14 Global Express aircraft and a delivery centre in which customers can choose design options in a virtual reality environment. The finishing touches, such as cabin furnishings, are installed here. A separate 7 246 square metre (78 000 square foot) paint and strip shop is located next to the completion centre, capable of housing up to four aircraft at a time.

Another 38 591 square metre (415 400 square foot) facility is located in Dorval, near the Bombardier Aerospace administrative centre and the Canadair aircraft assembly plant.

Airbus has an even larger operation. The A380 is assembled and delivered in Europe and has major structural components made in Australia, Canada, England, Finland, France, Germany, Italy, Malaysia, Mexico, Morocco, Russia, Spain, Turkey and the USA.

Suppliers, for both structural and minor components, are located around the world:

Australia	Wingtip fences	Mexico	Very large size special Hi-Lite® pull-in bolts
Canada	Pratt & Whitney Canada: Auxiliary power unit; and Goodrich: Body and wing landing gear	Morocco	Ducts for the air distribution system
England	Wings	Russia	Materials—titanium, aluminum, magnesium alloys and steel
Finland	Lift spoilers	Spain	Lateral boxes of the horizontal tail plane, the main landing gear doors, sections of the rear fuselage of the aircraft and the vertical stabilizer
France	France is the centre of A380 production	Sweden	Fixed leading edge from inner engine installation to wing tip. This includes wing spar, rib assemblies, system installation brackets and both inner and outer pylon fixed structures
Germany	Fuselage fabrication / assembly, aircraft finishing, waste water systems	Turkey	Large size special Hi-Lite® pull-in bolts of up to 28.5 mm (one inch) diameter, in both titanium and high-strength alloys, for the assembly of the most critical high-fatigue structural areas like wing spars, centre wing box and wing-to-fuselage junction
Italy	Central fuselage	USA	Airbus has an engineering design centre in Wichita, Kansas and many suppliers in the USA
Malaysia	Fixed leading edge lower panels and inboard outer fixed leading edge of wings	These are only the main supplier relationships that Airbus has developed around the world.	

Figure 1 Airbus A380 World-Wide Suppliers

Note. Created by Director Cadets 3, 2009, Ottawa, ON: Department of National Defence.



Show the cadets Figures B-1 to B-6 located at Attachment B. These pictures indicate the significance of the pylon fixed structures and pylon brackets that mount the four engines to the A380 wing. Each engine develops 31 750 kg (70 000 lbs) of thrust against the titanium pylons which transfer the thrust to the aircraft's wing.



Show the cadets Figure B-7 located at Attachment B, which lists Airbus A380 suppliers in North America.



For more information about how an A380 is made, the cadets can visit the Airbus Navigator at web page <http://events.airbus.com/A380/Default2.aspx?ArtId=644> or visit the Airbus website at [www.airbus.com](http://www.airbus.com).



---

**CONFIRMATION OF TEACHING POINT 2****QUESTIONS:**

- Q1. What characterizes a small manufacturer's shop?
- Q2. Where are large manufacturers located?
- Q3. What happens at a large manufacturer's completion facility?

**ANTICIPATED ANSWERS:**

- A1. All the aircraft parts and materials come together at one place prior to final assembly.
- A2. Around the world.
- A3. The finishing touches, such as cabin furnishings, are installed.

---

**END OF LESSON CONFIRMATION****QUESTIONS:**

- Q1. Why must an aircraft's structural components be aligned perfectly?
- Q2. What happens at a large manufacturer's completion facility?
- Q3. What is different with respect to career specialization between large and small manufacturers?

**ANTICIPATED ANSWERS:**

- A1. Any deviation or flaw will impair flight and have a negative effect upon flight controls.
- A2. The finishing touches, such as cabin furnishings, are installed.
- A3. Larger manufacturers generally have more career specialization than smaller ones.

---

**CONCLUSION**

---

**HOMEWORK / READING / PRACTICE**

Nil.

**METHOD OF EVALUATION**

Nil.

**CLOSING STATEMENT**

Precise assembly of large structures is a difficult yet critically important aspect of aircraft manufacturing, which benefits from continued development and improved techniques.

**INSTRUCTOR NOTES / REMARKS**

The cadets may have previously viewed The World's Biggest Airliner: The Airbus A380 if EO C270.04 was selected in Proficiency Level Two. This lesson focuses and expands on the assembly of aircraft.

Cadets who are qualified Advanced Aviation Technology – Aircraft Manufacturing and Maintenance may be able to assist with this lesson.

---

**REFERENCES**

---

C3-105 Brisley, T., & Pascaud, S. (Executive Producer), & Bowie, B. (Writer / Director) (2003). *World's biggest airliner: The Airbus A380* [Motion Picture]. United States: The Learning Channel.

C3-136 ISBN 0-88487-207-6 Sanderson Training Systems. (2001). *A&P technician airframe textbook*. Englewood, CO: Jeppesen Sanderson Inc.



Figure A-1 Rebuilding a C-130 Centre Wing

*Note.* From "L3 Communications Limited", 2007, *SPAR Aerospace: Globally Competitive Aerospace Solutions*. Retrieved October 23, 2007, from <http://www.spar.ca/>



Figure A-2 Placing a C-130 Centre Wing

*Note.* From "L3 Communications Limited", 2007, *SPAR Aerospace: Globally Competitive Aerospace Solutions*. Retrieved October 23, 2007, from <http://www.spar.ca/>



Figure A-3 Positioning a C-130 Centre Wing

*Note.* From "L3 Communications Limited", 2007, *SPAR Aerospace: Globally Competitive Aerospace Solutions*. Retrieved October 23, 2007, from <http://www.spar.ca/>



Figure A-4 Bombardier QR 400 Fuselage Assembly

*Note.* From "Media Centre", by Bombardier Aerospace, 2007, *QR 400 Assembly*. Retrieved November 1, 2007, from [http://www.bombardier.com/MediaCenter/Multimedia?action=view&gid=3\\_0&cid=295&page=1&Language=en](http://www.bombardier.com/MediaCenter/Multimedia?action=view&gid=3_0&cid=295&page=1&Language=en)





Figure A-5 Bombardier QR 400 Wing Assembly

*Note.* From "Media Centre", by Bombardier Aerospace, 2007, *QR 400 Assembly*. Retrieved November 1, 2007, from [http://www.bombardier.com/MediaCenter/Multimedia?action=view&gid=3\\_0&cid=295&page=1&Language=en](http://www.bombardier.com/MediaCenter/Multimedia?action=view&gid=3_0&cid=295&page=1&Language=en)



Figure A-6 Bombardier QR 400 Assembly Line

*Note.* From "Media Centre", by Bombardier Aerospace, 2007, *QR 400 Assembly*. Retrieved November 1, 2007, from [http://www.bombardier.com/MediaCenter/Multimedia?action=view&gid=3\\_0&cid=295&page=1&Language=en](http://www.bombardier.com/MediaCenter/Multimedia?action=view&gid=3_0&cid=295&page=1&Language=en)



Figure A-7 Bombardier QR 400 Assembly Activity

*Note.* From "Media Centre", by Bombardier Aerospace, 2007, *QR 400 Assembly*. Retrieved November 1, 2007, from [http://www.bombardier.com/MediaCenter/Multimedia?action=view&gid=3\\_0&cid=295&page=1&Language=en](http://www.bombardier.com/MediaCenter/Multimedia?action=view&gid=3_0&cid=295&page=1&Language=en)



Figure A-8 Bombardier QR 400 Engine Assembly

*Note.* From "Media Centre", by Bombardier Aerospace, 2007, *QR 400 Assembly*. Retrieved November 1, 2007, from [http://www.bombardier.com/MediaCenter/Multimedia?action=view&gid=3\\_0&cid=295&page=1&Language=en](http://www.bombardier.com/MediaCenter/Multimedia?action=view&gid=3_0&cid=295&page=1&Language=en)





Figure A-9 Bombardier CRJ700 Fuselage Assembly

*Note.* From "Media Centre", by Bombardier Aerospace, 2007, *CRJ700 Assembly*. Retrieved November 1, 2007, from [http://www.bombardier.com/MediaCenter/Multimedia?action=view&gid=3\\_0&cid=295&page=1&Language=en](http://www.bombardier.com/MediaCenter/Multimedia?action=view&gid=3_0&cid=295&page=1&Language=en)



Figure A-10 Bombardier CRJ700 Assembly Line

*Note.* From "Media Centre", by Bombardier Aerospace, 2007, *CRJ700 Assembly*. Retrieved November 1, 2007, from [http://www.bombardier.com/MediaCenter/Multimedia?action=view&gid=3\\_0&cid=295&page=1&Language=en](http://www.bombardier.com/MediaCenter/Multimedia?action=view&gid=3_0&cid=295&page=1&Language=en)



Figure A-11 Bombardier CRJ700 Assembly

*Note.* From "Media Centre", by Bombardier Aerospace, 2007, *CRJ700 Assembly*. Retrieved November 1, 2007, from [http://www.bombardier.com/MediaCenter/Multimedia?action=view&gid=3\\_0&cid=295&page=1&Language=en](http://www.bombardier.com/MediaCenter/Multimedia?action=view&gid=3_0&cid=295&page=1&Language=en)



Figure A-12 A Q400 Fuselage Arrives from MHI, Japan

*Note.* From "Media Centre", by Bombardier Aerospace, 2007, *QR 400 Assembly*. Retrieved November 1, 2007, from [http://www.bombardier.com/MediaCenter/Multimedia?action=view&gid=3\\_0&cid=295&page=1&Language=en](http://www.bombardier.com/MediaCenter/Multimedia?action=view&gid=3_0&cid=295&page=1&Language=en)





Figure B-1 Building a Pylon

*Note.* From "A380 Navigator", by Airbus, 2007, *Manufacturing Process*. Retrieved November 24, 2007, from <http://events.airbus.com/A380/Default2.aspx?ArtId=644>



Figure B-2 Pylon Ready to Go

*Note.* From "A380 Navigator", by Airbus, 2007, *Manufacturing Process*. Retrieved November 24, 2007, from <http://events.airbus.com/A380/Default2.aspx?ArtId=644>



Figure B-3 Pylon on Display

*Note.* From "A380 Navigator", by Airbus, 2007, *Manufacturing Process*. Retrieved November 24, 2007, from <http://events.airbus.com/A380/Default2.aspx?ArtId=644>



Figure B-4 Empty Pylons

*Note.* From "A380 Navigator", by Airbus, 2007, *Manufacturing Process*. Retrieved November 24, 2007, from <http://events.airbus.com/A380/Default2.aspx?ArtId=644>



Figure B-5 Engines on Pylons

*Note.* From "A380 Navigator", by Airbus, 2007, *Manufacturing Process*. Retrieved November 24, 2007, from <http://events.airbus.com/A380/Default2.aspx?ArtId=644>



Figure B-6 A380 with Engines

*Note.* From "A380 Navigator", by Airbus, 2007, *Manufacturing Process*. Retrieved November 24, 2007, from <http://events.airbus.com/A380/Default2.aspx?ArtId=644>





Figure B-7 Pylons at Work

*Note.* From "A380 Navigator", by Airbus, 2007, *Manufacturing Process*. Retrieved November 24, 2007, from <http://events.airbus.com/A380/Default2.aspx?ArtId=644>

### **L-3 COMMUNICATIONS AVIATION RECORDERS**

L-3 Communications Aviation Recorders (L-3AR) provides the flight data recorder and cockpit voice recorder for the A380.

### **ROCKWELL COLLINS**

Rockwell Collins' suite of communication and navigation sensors provides the baseline for the A380.

### **ALCOA**

Alcoa supplies forgings, extrusions, sheet, plate, and castings for the A380's wing and fuselage skins, stringers, frames, spars, gear ribs, engine and pylon support, seat tracks and floor beams.

### **C&D AEROSPACE**

California-based C&D Aerospace provides aircraft interior systems for the A380.

### **CYTEC - ENGINEERED MATERIALS**

Cytec Engineered Materials produces composites, adhesives and carbon fibres.

### **EATON CORPORATION**

US-based Eaton Corporation supplies the A380 with a highly-advanced higher-pressure hydraulic fluid power generation system, the world's first 5000-psi pump for a commercial aircraft.

### **HONEYWELL AEROSPACE**

Honeywell Aerospace will deliver 12 products and systems for the A380.

### **M.C.GILL CORPORATION**

M.C. Gill Corporation provides fully equipped composite floor panels for the cockpit of the A380, the main electronics bay situated below the cockpit and the emergency electronics bay, which sits forward of the upper deck passenger cabin.

### **MEGGITT SAFETY SYSTEMS**

Meggitt Safety Systems Inc.(MSSI) supplies the fire detection systems for the A380's engines, auxiliary power units (APUs) and main landing gears.

### **MONOGRAM SYSTEMS**

Monogram Systems, a unit of Zodiac's airline equipment branch in California, supplies an advanced water and vacuum waste system for the A380 that will incorporate state-of-the-art technical innovations.

### **NORTHROP GRUMMAN**

The navigation systems division of US defence company Northrop Grumman supplies the A380 with its LTN-101E global navigation air data inertial reference unit.

### **PARKER**

Parker Aerospace, a business unit of the Parker Hannifin Corporation, is participating in several work packages for the A380.

### **RALEE**

Ralee Engineering Company, a Triumph Group company based in California, supplies the wing top skin stringers (the metal structure that goes under the wing panels) for the A380.

Figure B-8 Airbus A380 North American Suppliers

*Note.* Created by Director Cadets 3, 2007, Ottawa, ON: Department of National Defence.

THIS PAGE INTENTIONALLY LEFT BLANK



**ROYAL CANADIAN AIR CADETS**  
**PROFICIENCY LEVEL FOUR**  
**INSTRUCTIONAL GUIDE**



**SECTION 3**

**EO C470.03 – IDENTIFY AVIATION HARDWARE**

Total Time:

30 min

**PREPARATION**

**PRE-LESSON INSTRUCTIONS**

Resources needed for the delivery of this lesson are listed in the lesson specification located in A-CR-CCP-804/PG-001, *Proficiency Level Four Qualification Standard and Plan*, Chapter 4. Specific uses for said resources are identified throughout the instructional guide within the TP for which they are required.

Review the lesson content and become familiar with the material prior to delivering the lesson.

The activity in TP 1 uses learning stations. Learning stations are a form of group work, where the cadets learn by sorting through the information presented. When setting up learning stations, ensure there is enough room for each cadet to be comfortable and adequate space for writing down information. When the cadets arrive at a learning station, all required information shall be available. These stations should be placed closely together to minimize time for movement; however, far enough apart to avoid interruptions from other groups. For this lesson, set up four learning stations for aviation hardware.

Photocopy the Aviation Hardware Handout located at Attachment A (one per cadet), Aviation Hardware Information Sheets located at Attachments B–E (one attachment per station), and the Aviation Hardware Identification Worksheet located at Attachment F (one per cadet).

**PRE-LESSON ASSIGNMENT**

Nil.

**APPROACH**

An in-class activity was chosen for this lesson as it is an interactive way to provoke thought and stimulate interest among cadets.

**INTRODUCTION**

**REVIEW**

Nil.

**OBJECTIVES**

By the end of this lesson the cadet shall have identified aviation hardware.

## **IMPORTANCE**

It is important for cadets to be able to identify aviation hardware as each type of hardware has a specific application. Using the correct type of aviation hardware during maintenance activities and the manufacturing of aircraft and aircraft components ensures that the design specifications and safety tolerances are maintained. Using the incorrect type of aviation hardware could jeopardize the safety of the aircrew, passengers, and personnel on the ground.



---

**Teaching Point 1****Conduct an activity where the cadets will identify aviation hardware.**

Time: 25 min

Method: In-Class Activity

---

**ACTIVITY****OBJECTIVE**

The objective of this activity is to have the cadets identify aviation hardware.

**RESOURCES**

- Pen / pencil,
- Aviation Hardware Handout located at Attachment A,
- Aviation Hardware Information Sheets located at Attachments B–E,
- Aviation Hardware Identification Worksheet located at Attachment F, and
- Aviation Hardware Identification Worksheet Answer Key located at Attachment G.

**ACTIVITY LAYOUT**

If samples of aviation hardware are available, place them at the appropriate learning station.

**ACTIVITY INSTRUCTIONS**

1. Brief cadets on activity instructions, to include:
  - a. time limit for each station (five minutes),
  - b. direction of rotation between stations,
  - c. signal for rotation,
  - d. explanation of Aviation Hardware Information Sheets, and
  - e. an overview of the Aviation Hardware Identification Worksheet.
2. Distribute the Aviation Hardware Identification Worksheet located at Attachment F (to each cadet).
3. Divide the cadets into four groups and assign a number to each group.
4. Have groups move to the learning station which corresponds to their group number.
5. Have the cadets complete the Aviation Hardware Identification Worksheet while rotating from station to station every five minutes.



It is important to circulate around the room to facilitate the activities and help the cadets as required. If possible, assign other instructors to aid with the supervision and facilitation.

6. Once each group has been to each station, have one cadet from each group share the information they recorded from the station they just completed with the rest of the cadets. In most cases, the groups will have recorded the same information for each station. If a group has listed different information, have them share their answers.

## **SAFETY**

Nil.

---

## **CONFIRMATION OF TEACHING POINT 1**

The cadets' participation in the activity will serve as the confirmation of this TP.

---

## **END OF LESSON CONFIRMATION**

The cadets' completion of the Aviation Hardware Identification Worksheet will serve as the confirmation of this lesson.

---

## **CONCLUSION**

---

## **HOMEWORK / READING / PRACTICE**

Nil.

## **METHOD OF EVALUATION**

Nil.

## **CLOSING STATEMENT**

Aviation hardware comes in a variety of types, each with a specific application. Using the correct type of aviation hardware during the manufacture and maintenance of aircraft and aircraft components is important to ensure that the safety of the aircrew, passengers, and personnel on the ground is not compromised.

## **INSTRUCTOR NOTES / REMARKS**

Cadets who are qualified Advanced Aviation Technology – Aircraft Manufacturing and Maintenance may be able to assist with this lesson.

---

## **REFERENCES**

C3-136 ISBN 0-88487-207-6 Sanderson Training Systems. (2001). *A&P technician airframe textbook*. Englewood, CO: Jeppesen Sanderson Inc.

C3-137 ISBN 0-88487-203-3 Sanderson Training Systems. (2000). *A&P technician general textbook*. Englewood, CO: Jeppesen Sanderson Inc.

### Aviation Hardware Handout

Aviation hardware refers to the different types of fasteners and small items used during the manufacture and maintenance of aircraft and aircraft components. Although many of these items are small in size, their importance is large.

With more than 30 000 different fasteners available for aviation applications, it is important to be able to identify the different types of aviation hardware as their correct use is paramount for the safe and efficient operation of aircraft.

Aviation hardware comes in a variety of shapes and sizes, as well as in a variety of materials. Over the years, there have been many different ways to standardize the description of aviation hardware.

AMS (Aeronautical Material Specifications)	AN (Air Force–Navy)
AND (Air Force–Navy Design)	AS (Aeronautical Standard)
ASA (American Standards Association)	ASTM (American Society for Testing and Materials)
MS (Military Standard)	NAF (Naval Aircraft Factory)
NAS (National Aerospace Standard)	SAE (Society of Automotive Engineers)

Figure A-1 Aviation Hardware Specifications and Standards Codes

*Note.* From *A&P Technician General Textbook* (p. 8-2), by Jeppesen Standard Training Products, 2000, Englewood, CO: Jeppesen Sanderson Training Systems.

The two most common specification and standard identification systems used in aviation today are the Air Force–Navy (AN) and Military Standards 20 (MS20) systems. Both systems use a similar coding method to describe the physical characteristics of aviation hardware (eg, rivets, bolts, nuts, etc). An example of this is shown in Figure A-2. While there are minor differences between different systems, the same piece of hardware can be described by different systems (eg, an AN365 self-locking nut is the same as a MS20365 self-locking nut).

Rivet Designation	Physical Characteristics	
AN470-AD4-5	AN	Specification and standard (Air Force–Navy system)
	470	Head style (universal head)
	AD	Material code (2117 aluminum alloy)
	4	Diameter (4/32 inch)
	5	Length (5/16 inch)

Figure A-2 Rivet Specification Decoded

*Note.* Created by Director Cadets 3, 2009, Ottawa, ON: Department of National Defence.

Although there are many different types of fasteners used in aviation, there are five main categories:

- bolts (includes washers and nuts),
- rivets,
- special fasteners,

- machine screws, and
- turnlock fasteners.

Each category has its own unique terminology, although some terms may have similar meanings, as well as special tools and procedures for installation and removal.

Fasteners are used in two distinct applications in aviation: structural and non-structural. When used as a structural fastener, it is especially important that the correct hardware is used as the hardware forms part of the structure of the aircraft and is expected to be able to carry a specific load without failing.

Examples of structural fasteners include:

- bolts connecting the wing spar to the fuselage,
- rivets connecting the wing skin to the wing ribs, and
- bolts connecting the landing gear to the fuselage.

Examples of non-structural fasteners include:

- turnlock fasteners on inspection covers and cowlings,
- machine screws on interior panels, and
- bolts holding instruments in place in the instrument panel.

Aircraft plans, parts manuals, and repair manuals all include very specific details on the exact type of aviation hardware to be used. Builders and maintenance personnel must not substitute alternate hardware without ensuring that design specifications are not compromised.

When compared to standard or automotive hardware, aviation hardware is manufactured to higher standards, generally has a higher strength rating, and may come with a variety of finish or coating option. While non-aviation hardware may be legal for use on home-built aircraft, most associations strongly recommend the use of aviation hardware.

## BOLTS

A bolt is designed to hold two or more items together. Bolts come in a variety of sizes, shapes, materials and strengths so that the correct fastener can be used for each application. Bolts are used for both structural and non-structural applications.

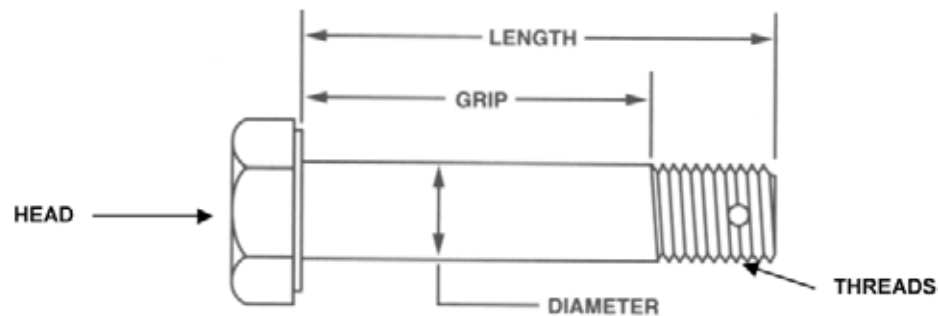

Figure B-1 AN (Airforce Navy) Bolt Dimensions

*Note.* From *A&P Technician General Textbook* (p. 8-17), by Jeppesen Standard Training Products, 2000, Englewood, CO:Jeppesen Sanderson Training Systems.

### Standard AN Bolt Classification

Standard bolts classified using the AN system, are classified using the diameter and length, and additional modifiers (eg, material, drilled holes) are added. Diameters are indicated in 1/16-inch increments and length in 1/8-inch increments.

For example, an AN4-7 bolt has a diameter of 4/16 inch (1/4 inch) and a length of 7/8 inch. The length of the bolt is also known as the dash number. Dash numbers of eight and nine (-8 and -9) are not used. This means that a bolt length of 1 inch is represented with -10 (2 inches is -20, 3 inches is -30). For example, an AN5-22 bolt has a diameter of 5/16 inch and is 2-2/8 inches long (2-1/4 inches).

The material used for the bolt is indicated by replacing the dash with letters to indicate the material (the dash indicates that the bolt is made of cadmium-plated nickel steel). A corrosion-resistant bolt is represented with the letter C. Aluminum alloy bolts use the letters DD.

Standard bolts have a hole drilled in the threaded portion for a cotter pin (to keep the nut from coming off). To indicate a bolt without a hole, the letter A is added to the end of the bolt number (eg, AN5-22A). To indicate a bolt that has a hole drilled in the head (for locking wire), the letter H is inserted after the diameter (eg, AN6H34).

### Threads

Threads are classified by the number of threads per inch (the number of times the threads rotate [number of turns] around a 1-inch length of a given diameter bolt or screw). Different standards for threads are American National Coarse (NC), American National Fine (NF), American Standard Unified Coarse (UNC), and American Standard Unified Fine (UNF).

Threads are also designated by the class of fit (from one to five). A Class 1 thread is a loose fit (the nut may be turned all the way from start to finish with just your fingers). A Class 5 thread is a tight fit (the nut requires a wrench from start to finish). Most aviation bolts are fine threaded with a Class 3 fit.

## Nuts and Washers

Nuts are threaded onto the end of the bolt to prevent it from coming out. In some applications, the nut may also carry a load. Due to the vibrations experienced in a typical aircraft, most nuts must be locked onto the bolts. To keep the nut from coming loose, a cotter pin can be inserted through the hole in the bolt (a castle nut is used in this type of application) or a lock nut (nylon or metal) is used.

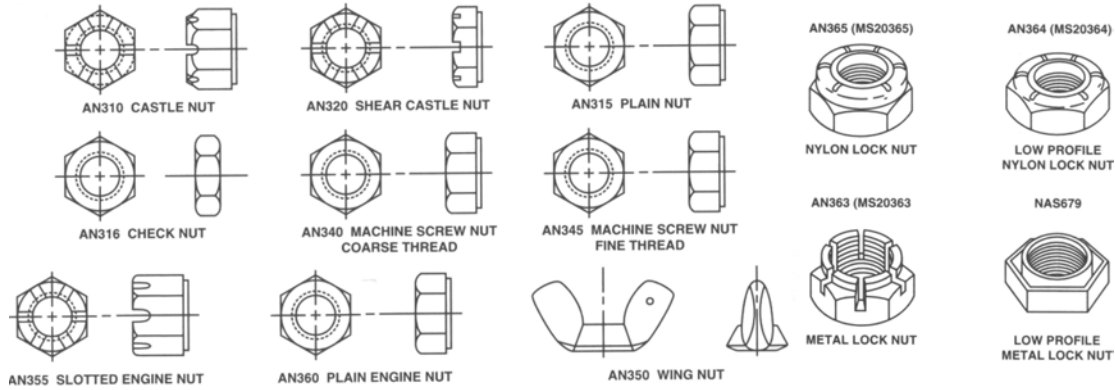

Figure B-2 Standard Aircraft Nuts

*Note.* From *A&P Technician General Textbook* (p. 8-21), by Jeppesen Standard Training Products, 2000, Englewood, CO:Jeppesen Sanderson Training Systems.

Washers are used to ensure that the bolt fits properly, to prevent the nut and / or bolt head from damaging the parts, and in the case of lock washers, to help prevent the nut from coming loose.

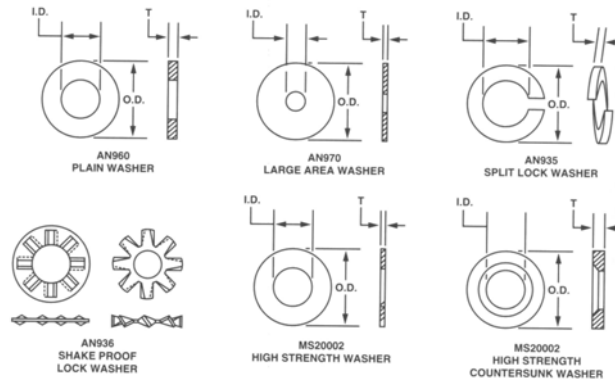

Figure B-3 Aircraft Washers

*Note.* From *A&P Technician General Textbook* (p. 8-30), by Jeppesen Standard Training Products, 2000, Englewood, CO:Jeppesen Sanderson Training Systems.

## RIVETS

Rivets are used to join metal parts together, especially sheet metal parts (eg, attaching the metal skin of the wing to the metal ribs in the wing). When installed properly, rivets create a joint at least as strong as the material being joined.

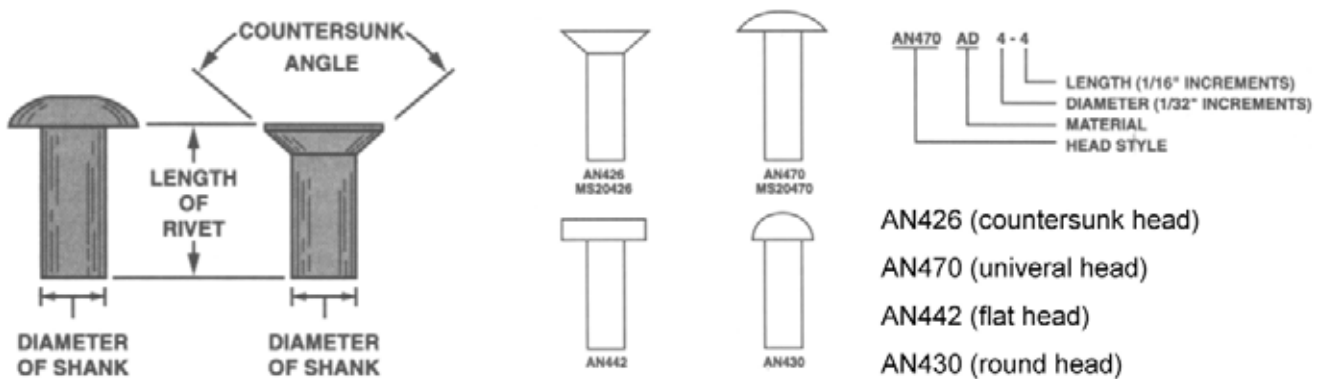

Figure C-1 Dimensions and AN Designations

*Note.* From *A&P Technician Airframe Textbook* (p. 2-36), by Jeppesen Standard Training Products, 2000, Englewood, CO: Jeppesen Sanderson Training Systems.

The general process for installing a rivet is to drill a hole slightly larger than the initial diameter of the rivet in the two pieces being joined. The rivet is inserted into the hole, and both ends of the rivet are carefully pressed together using special tools (a rivet gun on the head, and a bucking bar on the opposite end). The shank of the rivet swells to fill the hole, and the end of the rivet flattens out.

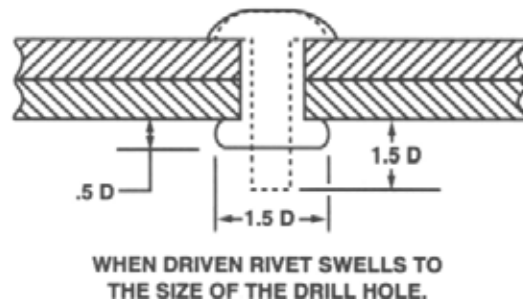

Figure C-2 Before and After Driving a Rivet

*Note.* From *A&P Technician Airframe Textbook* (p. 2-36), by Jeppesen Standard Training Products, 2000, Englewood, CO: Jeppesen Sanderson Training Systems.

## Special Rivets

Standard rivets require access to both ends of the rivet to properly install it. Special rivets that only require access to one end have been developed for use in areas of the aircraft where it is not possible to access both ends of the rivet. These special rivets are also known as blind rivets and come in a variety of styles, usually identified by a brand name (eg, Huck-Lok, CherryLOCK, CherryMAX, Olympic-Lok).

## Pop Rivets

Pop rivets are a type of special rivet (blind rivet). Although very common in non-aviation applications, pop rivets have limited uses in aviation. They are never used for structural applications, except as a temporary way to line up parts while installing permanent rivets.

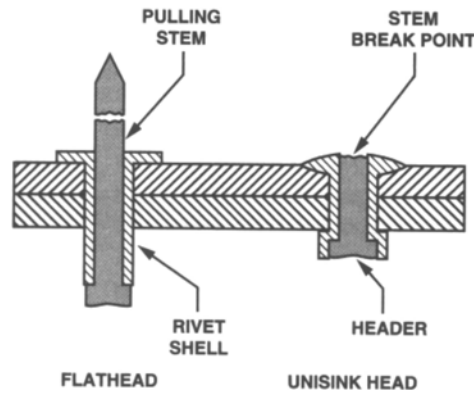

Figure C-3 Pop Rivets

*Note.* From *A&P Technician Airframe Textbook* (p. 2-40), by Jeppesen Standard Training Products, 2000, Englewood, CO:Jeppesen Sanderson Training Systems.

### Cleco Fasteners

Prior to installing rivets, the parts need to be properly aligned and held in place. The most common method for doing this is by clamping the parts together. One of the most common clamping devices used in aviation is the Cleco fastener. A Cleco fastener is basically just a removable rivet.



Figure C-4 Cleco Pliers and Cleco Fasteners

*Note.* From "Cleco Pliers, Cleco Tool for Cleco Fasteners", *William Lees Sons Ltd.* Retrieved March 24, 2009, from <http://www.skinpins.com/toolsC200pliers.html>

A Cleco fastener is inserted into a hole (that will eventually hold a rivet) using a special pair of pliers and clamps the metal pieces together. Once the pieces are properly aligned (usually with a Cleco fastener in each rivet hole) the Cleco fasteners are removed one at a time and replaced by the permanent rivet.

Cleco fasteners come in different sizes that correspond to common rivet sizes. Each size is colour coded for easy identification.



<b>Rivet / Cleco Diameter</b>	<b>Rivet Diameter Dash Number</b>	<b>Colour</b>
3/32 inch	-3	Silver
1/8 inch	-4	Copper
5/32 inch	-5	Black
3/16 inch	-6	Brass
1/4 inch	-8	Copper

Figure C-5 Cleco Fastener Diameters and Colours

*Note.* From *A&P Technician Airframe Textbook* (p. 2-34), by Jeppesen Standard Training Products, 2000, Englewood, CO: Jeppesen Sanderson Training Systems.

THIS PAGE INTENTIONALLY LEFT BLANK

## SCREWS

Screws are a very common threaded fastener in aviation and there are three basic classifications: machine screws, structural screws, and self-tapping screws. Screws generally have a loose fitting thread (eg, Class 2) and may have either a clearly defined grip length that is partially threaded or be threaded along their entire length. While most screws have heads designed to accept a screwdriver, some have heads that require a wrench.

### Machine Screws

Machine screws are generally used for attaching fairings, inspection plates, fluid line clamps, and other light structural parts. Machine screws are usually threaded along their entire length and are available with national coarse or national fine threads. These screws may be made of several different types of materials and may be coated or treated in various ways.

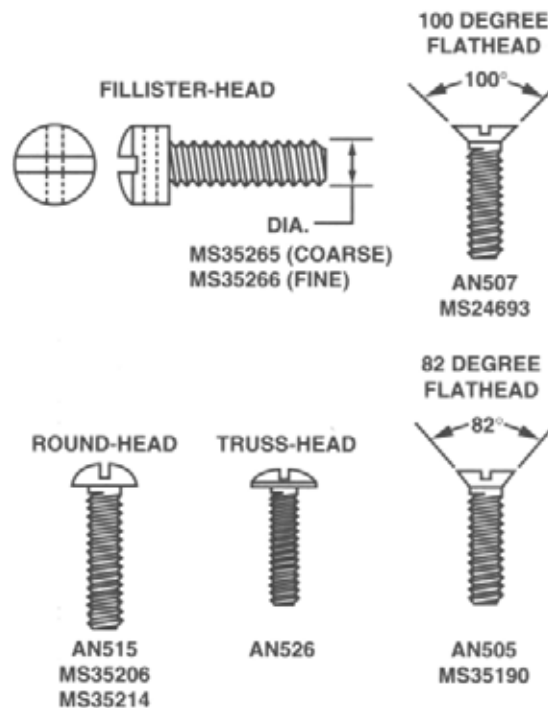

Figure D-1 Machine Screws

*Note.* From *A&P Technician General Textbook* (p. 8-27), by Jeppesen Standard Training Products, 2000, Englewood, CO:Jeppesen Sanderson Training Systems.

### Structural Screws

Structural screws are very similar to standard bolts. They are heat treated and have the same shear strength as a bolt of the same size. Shank tolerances are similar to bolts and the threads are national fine.

### Self-Tapping Screws

Self-tapping screws are used to hold thin sheets of metal, plastic, or plywood together. They have a coarse thread and come with a sharp (Type A) or blunt (Type B) point.

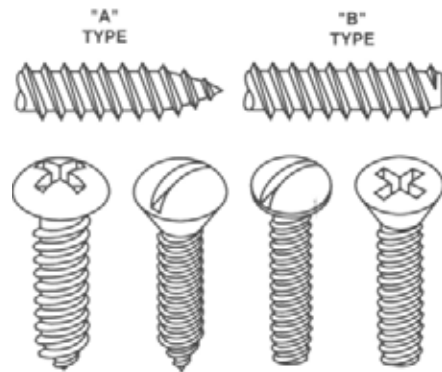

Figure D-2 Self-Tapping Sheet Metal Screws

*Note.* From *A&P Technician General Textbook* (p. 8-28), by Jeppesen Standard Training Products, 2000, Englewood, CO:Jeppesen Sanderson Training Systems.

## TURNLOCK FASTENERS

Turnlock fasteners are used when quick and easy removal or opening of access panels, doors, and cowlings is required. There are three common types, each identified by their trade or brand name: Dzus, Airloc, and Camlock.

### Dzus Fastener

Dzus (pronounced Zeus) fasteners are commonly found on cowling and inspection panels that must be frequently opened. The stud is mounted on the cowling or panel, and fits into the receptacle when the parts are aligned (closed). A quarter turn of the stud opens or closes the fastener. When closed, the stud grips a spring in the receptacle which keeps it closed.

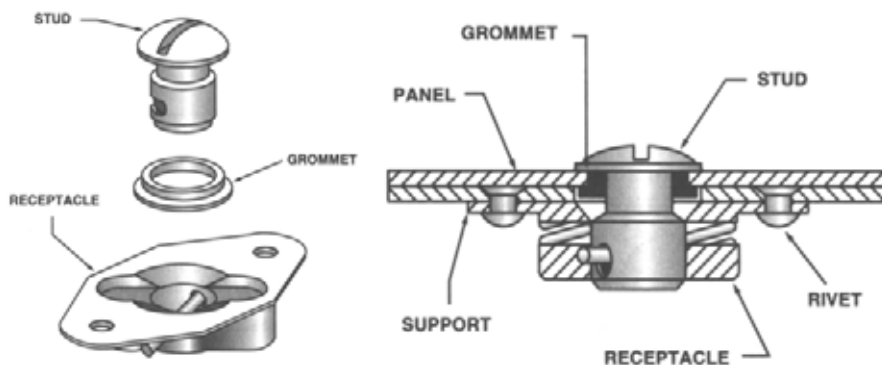

Figure E-1 Dzus® Fastener

*Note.* From *A&P Technician Airframe Textbook* (p. 2-49), by Jeppesen Standard Training Products, 2000, Englewood, CO:Jeppesen Sanderson Training Systems.

### Airloc Fasteners

Airloc fasteners use a stud that has a pin, as opposed to Dzus fasteners that have a notch in the pin. When turned, the pin engages the spring in the receptacle. These fasteners are used in the same applications as Dzus fasteners.

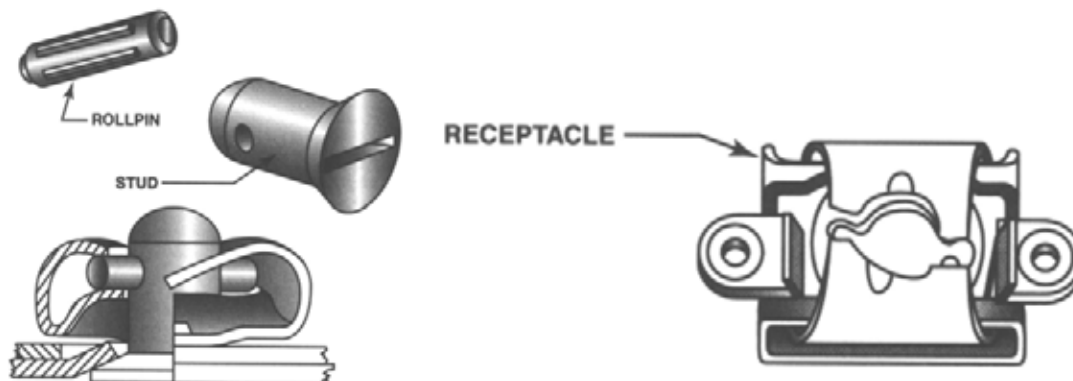

Figure E-2 Airloc® Cowling Fastener

*Note.* From *A&P Technician Airframe Textbook* (p. 2-50), by Jeppesen Standard Training Products, 2000, Englewood, CO:Jeppesen Sanderson Training Systems.

### Camlock Fasteners

Camlock fasteners have a stud assembly that includes a spring and a pin. When the stud is pressed into the receptacle, the spring compresses and allows the pin to be rotated into position in the receptacle. When the stud is released, the spring expands, and holds the pin in place in a groove in the bottom of the receptacle.

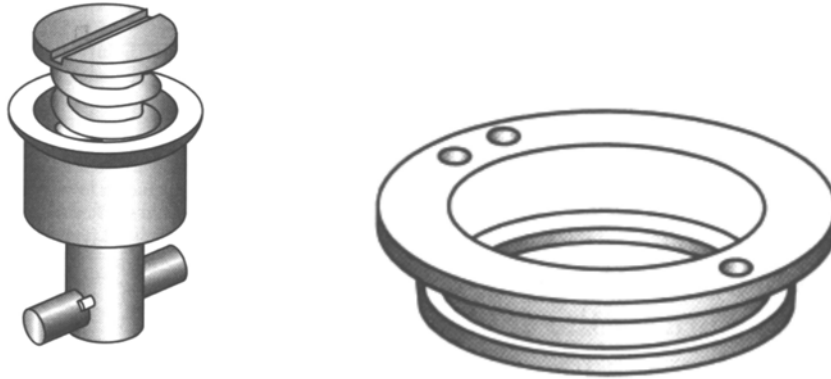

Figure E-3 Camlock® Cowling Fastener

*Note.* From *A&P Technician Airframe Textbook* (p. 2-50), by Jeppesen Standard Training Products, 2000, Englewood, CO:Jeppesen Sanderson Training Systems.

### Aviation Hardware Identification Worksheet

#### Aviation Hardware

What two specification and standard identification systems are the most common?

\_\_\_\_\_, and  
\_\_\_\_\_.

#### Bolts

Identify the aviation hardware shown below:

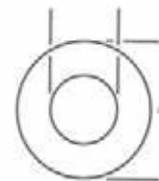

\_\_\_\_\_

An AN7-12 bolt:

- has a length of \_\_\_\_\_ inch(es),
- has a diameter of \_\_\_\_\_ inch(es),
- is made of \_\_\_\_\_, and
- \_\_\_\_\_ a hole drilled in the head for lock wire.

\_\_\_\_\_

An AN3-13A bolt:

- has a length of \_\_\_\_\_ inch(es),
- has a diameter of \_\_\_\_\_ inch(es),
- is made of \_\_\_\_\_, and
- \_\_\_\_\_ a hole drilled in the threads for a cotter pin.

#### Rivets

Identify the aviation hardware shown below:



\_\_\_\_\_

An AN442AD4-4 rivet:

- has a length of \_\_\_\_\_ inch(es),
- has a diameter of \_\_\_\_\_ inch(es), and
- has a \_\_\_\_\_ head.

Pop rivets \_\_\_\_\_ used for structural applications.

\_\_\_\_\_ are used when there is not easy access to both ends of the rivet.

### Screws

Identify the aviation hardware shown below:



\_\_\_\_\_

\_\_\_\_\_

Most screws are installed using a \_\_\_\_\_. Some screws may require a \_\_\_\_\_ to install them.

### Turnlock Fasteners

Identify the aviation hardware shown below:

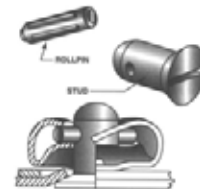
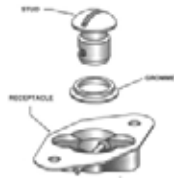
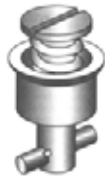

\_\_\_\_\_

\_\_\_\_\_

\_\_\_\_\_

Most turnlock fasteners only need to be turned \_\_\_\_\_ to be opened or closed.



## Aviation Hardware Identification Worksheet Answer Key

### Aviation Hardware

What two specification and standard identification systems are the most common?

  AIR FORCE-NAVY (AN)  , and  
  MILITARY STANDARDS 20 (MS20)  .

### Bolts

Identify the aviation hardware shown below:



  AIRCRAFT BOLTS  



  NYLON LOCK NUT  



  PLAIN WASHER (AN690)  

An AN7-12 bolt:

- has a length of   1-1/4   inch(es),
- has a diameter of   7/16   inch(es),
- is made of   CADMIUM-PLATED NICKEL STEEL  , and
- DOES NOT HAVE   a hole drilled in the head for lock wire

An AN3-13A bolt:

- has a length of   1-3/8   inch(es),
- has a diameter of   3/16   inch(es),
- is made of   CADMIUM-PLATED NICKEL STEEL  , and
- DOES NOT HAVE   a hole drilled in the threads for a cotter pin.

### Rivets

Identify the aviation hardware shown below:



  ROUND HEAD RIVET  
  (AN430)  



  CLECO FASTENER

An AN442AD4-4 rivet:

- has a length of 1/4 inch(es),
- has a diameter of 1/8 inch(es), and
- has a FLAT head.

Pop rivets ARE NOT used for structural applications.

SPECIAL (BLIND) RIVETS are used when there is not easy access to both ends of the rivet.

### Screws

Identify the aviation hardware shown below:



MACHINE SCREW



SELF-TAPPING SCREW

Most screws are installed using a SCREWDRIVER. Some screws may require a WRENCH to install them.

### Turnlock Fasteners

Identify the aviation hardware shown below:

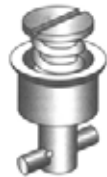

DZUS FASTENER

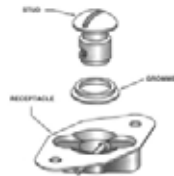

CAMLOCK FASTENER

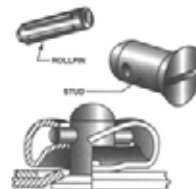

AIRLOC FASTENER

Most turnlock fasteners only need to be turned ONE QUARTER OF A TURN to be opened or closed.



**ROYAL CANADIAN AIR CADETS  
PROFICIENCY LEVEL FOUR  
INSTRUCTIONAL GUIDE**



**SECTION 1**

**EO M490.01 – ASSEMBLE AN EMERGENCY SURVIVAL KIT**

---

Total Time:	30 min
-------------	--------

---

**PREPARATION**

---

**PRE-LESSON INSTRUCTIONS**

Resources needed for the delivery of this lesson are listed in the lesson specification located in A-CR-CCP-804/PG-001, *Proficiency Level Four Standard and Plan*, Chapter 4. Specific uses for said resources are identified throughout the instructional guide within the TP for which they are required.

Review the lesson content and become familiar with the material prior to delivering the lesson.

Gather the emergency kit items needed for TP 3.

**PRE-LESSON ASSIGNMENT**

Nil.

**APPROACH**

An interactive lecture was chosen for TPs 1 and 2 to present basic material and give direction on assembling an emergency survival kit.

An in-class activity was chosen for TP 3 as it is an interactive way to provoke thought and stimulate interest among cadets about emergency survival kits.

---

**INTRODUCTION**

---

**REVIEW**

Nil.

**OBJECTIVES**

By the end of this lesson the cadets shall have assembled an emergency survival kit.

**IMPORTANCE**

It is important for cadets to be prepared for survival situations. Carrying an emergency survival kit at all times while in the field and knowing the purpose of the contents may help the cadets to react appropriately to survival situations.

---

**Teaching Point 1****Discuss the characteristics of an emergency survival kit.**

Time: 5 min

Method: Interactive Lecture

---

**ESSENTIAL ITEMS**

The items carried in a personal emergency survival kit must meet the needs of a person in a survival situation. The essential items to fulfill these needs can be categorized.

**Personal protection.** This includes clothing, shelter, and fire.

**Signalling.** Constructed signals are ground-to-air signals and signal fires. An improvised signal may be a piece of shiny metal used as a signal mirror.

**Sustenance.** Water and food.

**Travel.** Navigating with and without a compass.

**Health.** This includes trauma and environmental injuries as well as mental health, which affects the will to survive.

**SMALL AND EASY TO CARRY IN A POCKET**

If the emergency survival kit is not with the person when it is needed, it is worthless. It needs to be carried at all times during outdoor activities.

It should be small enough to fit into a pocket, but not so bulky as to restrict movement.

It should be easy and comfortable to carry so that once placed in the pocket, it stays there until the outdoor activities are over or it is needed.

---

**CONFIRMATION OF TEACHING POINT 1****QUESTIONS:**

- Q1. Name the five categories that should be considered when choosing essential items for an emergency survival kit.
- Q2. When should you carry an emergency survival kit?
- Q3. Where should an emergency survival kit be located?

**ANTICIPATED ANSWERS:**

- A1. Personal protection, signalling, sustenance, travel, and health.
- A2. At all times during outdoor activities.
- A3. It should be in your pocket.

---

**Teaching Point 2****Explain that emergency survival kit items should be placed in a durable container that is lightweight and waterproof.**

Time: 5 min

Method: Interactive Lecture

---

The items in an emergency survival kit need to be readily available and in a useable condition, neither damaged by water nor compression (squished).

**DURABLE**

A container for an emergency survival kit must be durable to prevent compression, which can damage the items within.

**LIGHTWEIGHT**

The container should be lightweight. If it is too heavy, it becomes a burden to carry and therefore may be packed in the rucksack / backpack and not with the person when needed.

**WATERPROOF**

The container should be waterproof to protect items from water damage. Damaged items may be of no help in a survival situation.

Different types of containers have different characteristics which should be taken into account before deciding on which type a person will use. Types of containers include:

- **Hard plastic.** Very durable but may be uncomfortable to carry in a pocket.
- **Flexible plastic.** Durable, more comfortable than hard plastic in a pocket.
- **Metal.** Very durable but may be uncomfortable to carry in a pocket. However, unlike the plastic containers, a metal container may be used over a fire for multiple uses (eg, cooking, purifying water).

**CONFIRMATION OF TEACHING POINT 2****QUESTIONS:**

- Q1. What three features should an emergency survival kit container have?
- Q2. What are the differences between containers made from hard and flexible plastic?
- Q3. What may be done with a metal container but not a plastic one?

**ANTICIPATED ANSWERS:**

- A1. It should be durable (to prevent compression), lightweight and waterproof (to protect items from water damage).
- A2. The hard plastic container is more durable, but the flexible plastic container will be more comfortable to carry in a pocket.
- A3. It may be used over a fire.

**Teaching Point 5**

**Explain the purpose of each emergency survival kit item and have the cadets, as a group, assemble an emergency survival kit.**

Time: 15 min

Method: In-Class Activity

**BACKGROUND KNOWLEDGE****THE PURPOSE OF EACH EMERGENCY SURVIVAL KIT ITEM**

**Adhesive bandages.** Used for minor first aid.

**Aluminum foil.** May be used for cooking, water collection, and signalling.

**Antibiotic tablets.** Used to reduce the health risk of injuries.

**Button compass.** Used to determine direction.

**Candle.** May be used as a light source and a fire starter.

**Condom.** Used for water storage.

**Cord.** Used for lashings in multiple applications.

**Cotton balls.** May be used as tinder and to perform minor first aid.

**Emergency blanket.** Used to keep warm and may also be used for signalling.

**Fish hooks.** Used to catch fish.

**Fishing line.** Used to catch fish, but may also be used for lashings.

**Fishing sinkers.** Used to catch fish.

**Flexible saw.** Used to cut wood.

**Garbage bag (small).** This item has multiple uses: for raingear, as a water collector and for food storage.

**Hard candies.** Used as an energy food. It is also a morale booster.

**Magnifying glass.** Used to light fires and for first aid (to find small splinters).

**Mirror (small).** Used for signalling.

**Moleskin.** This item may be used as minor first aid for blisters.

**Pain reliever (pills).** Acetylsalicylic acid or acetaminophen, used as a pain reliever.

**Paper.** Used to write notes and may be used as tinder.

**Pencil.** Used to write notes.

**Personal medication.** Used to maintain health.

**Re-sealable plastic bags (very small).** Used to waterproof and organize small items within the kit.

**Safety pins.** These have multiple uses: to perform minor first aid and to repair clothing and equipment.

**Salt.** Used to maintain health.

**Sewing needles.** This item may be used for minor first aid and to repair clothing and equipment.

**Small folding knife.** Most versatile item in the survival kit.

**Snare wire.** Used to catch small animals and may also be used for lashings.

**Thread.** This item has multiple uses: used to create small lashings, for minor first aid and to repair clothing and equipment.

**Tweezers.** Used for minor first aid and to untie knots (so cord may be reused).

**Water purification tablets.** Used to purify water.

**Waterproof matches.** Used to light fires.

**Whistle.** Used to signal for help and to help scare off animals.

---

## ACTIVITY

Time: 15 min

### OBJECTIVE

The objective of this activity is to have the cadets assemble an emergency survival kit.

### RESOURCES



This is not an exhaustive list and is designed to give cadets an idea of what an emergency survival kit could contain.

- hard or flexible plastic or metal container,
- adhesive bandages,
- aluminum foil,
- antibiotic tablets,
- button compass,
- candle,
- condom,
- cord,
- cotton balls,
- emergency blanket,
- fish hooks,
- fishing line,
- fishing sinkers,
- flexible saw,
- garbage bag (small),
- hard candies,
- magnifying glass,
- mirror (small),
- moleskin,
- pain reliever (pills),

- paper,
- pencil,
- personal medication,
- resealable plastic bags (very small),
- safety pins,
- salt,
- sewing needles,
- small folding knife,
- snare wire,
- thread,
- tweezers,
- water purification tablets,
- waterproof matches, and
- whistle.

### **ACTIVITY LAYOUT**

Nil.

### **ACTIVITY INSTRUCTIONS**

1. Show the cadets the hard or flexible plastic or metal container to be used for the emergency survival kit.
2. Ask the cadets what items should be in an emergency survival kit.
3. As each item is suggested, list it on the whiteboard / flip chart.
4. If the item suggested has been brought as an example, show it to the cadets.
5. Describe the purpose of the item.
6. Pass the item to a cadet.
7. Have the cadet place the item into the hard or flexible plastic or metal container to create an emergency survival kit.
8. Repeat Steps 3–7.



Ensure the items that are listed but not brought as examples are explained to the cadets.

### **SAFETY**

Nil.



---

**CONFIRMATION OF TEACHING POINT 3**

The cadets' participation in the activity and the assembly of an emergency survival kit will serve as the confirmation of this TP.

---

**END OF LESSON CONFIRMATION**

The cadets' assembly of an emergency survival kit will serve as the confirmation of this lesson.

---

**CONCLUSION**

---

**HOMEWORK / READING / PRACTICE**

This EO is assessed IAW A-CR-CCP-804/PG-001, *Proficiency Level Four Standard and Plan*, Chapter 3, Annex B, 490 PC.

**METHOD OF EVALUATION**

Nil.

**CLOSING STATEMENT**

Being in possession of an emergency survival kit will greatly enhance your capabilities in a survival situation.

**INSTRUCTOR NOTES / REMARKS**

Cadets who are qualified Survival Instructor may assist with this instruction.

---

**REFERENCES**

---

C2-010 ISBN 0-375-70323-3 Rawlins, C., & Fletcher, C. (2004). *The complete walker IV*. New York, NY: Alfred A. Knopf.

C3-002 ISBN 0-00-653140-7 Wiseman, J. (1999). *SAS survival handbook*. Hammersmith, London: HarperCollins Publishers.

C3-003 ISBN 1-896713-00-9 Tawrell, P. (1996). *Camping and wilderness survival: The ultimate outdoors book*. Green Valley, ON: Author.

C3-150 ISBN 978-0-8117-3292-5 Davenport, G. (2002). *Wilderness survival*. Mechanicsburg, PA: Stackpole Books.

THIS PAGE INTENTIONALLY LEFT BLANK



**ROYAL CANADIAN AIR CADETS  
PROFICIENCY LEVEL FOUR  
INSTRUCTIONAL GUIDE**



**SECTION 2**

**EO M490.02 – OPERATE A STOVE AND A LANTERN**

---

Total Time:	90 min
-------------	--------

---

**PREPARATION**

---

**PRE-LESSON INSTRUCTIONS**

Resources needed for the delivery of this lesson are listed in the lesson specification located in A-CR-CCP-804/PG-001, *Proficiency Level Four Qualification Standard Plan*, Chapter 4. Specific uses for said resources are identified throughout the instructional guide within the TP for which they are required.

Review the lesson content and become familiar with the material prior to delivering the lesson.

The lesson has been designed using the common features of naphtha fuelled two-burner stoves and dual-mantle lanterns. Consult the operating manuals of the equipment to be used, and if necessary, modify the TPs accordingly.

**PRE-LESSON ASSIGNMENT**

Nil.

**APPROACH**

An interactive lecture was chosen for TPs 1 and 2 to introduce to the cadets the characteristics of the stove and of the lantern.

A demonstration and performance was chosen for TPs 3–6 as it allows the instructor to explain and demonstrate how to operate a stove and lantern while providing an opportunity for the cadets to practice the skill under supervision.

---

**INTRODUCTION**

---

**REVIEW**

Nil.

**OBJECTIVES**

By the end of this lesson the cadet shall have operated and a stove and a lantern.

**IMPORTANCE**

It is important for cadets to safely operate and maintain the stoves and lanterns most commonly used during field training. While on field training, a base of operations is required to support survival training.

---

**Teaching Point 1**

**Identify the characteristics of a two-burner naphtha stove.**

Time: 10 min

Method: Interactive Lecture

---

**CHARACTERISTICS**

The following are characteristics of a two-burner naphtha stove:

- It is capable of operating with a clean, smokeless flame.
- The flame can be quickly extinguished.
- It is easily ignited in cold weather.
- It is easy to refuel.
- It has no noxious odours.
- Fuel in the tank will not spill when being carried in any position.
- It cools quickly.
- It is easily cleaned and repaired.

**Operational Temperature**

A two-burner stove (that uses naphtha as a fuel), when shielded from the wind, can be used in temperatures as low as -52 Celsius.

**Fuel Type**

The stove uses naphtha. (Note: also known as white gas, camping fuel and Coleman fuel.)

**Parts and Accessories**



The following diagram is provided for part identification, not disassembly purposes.

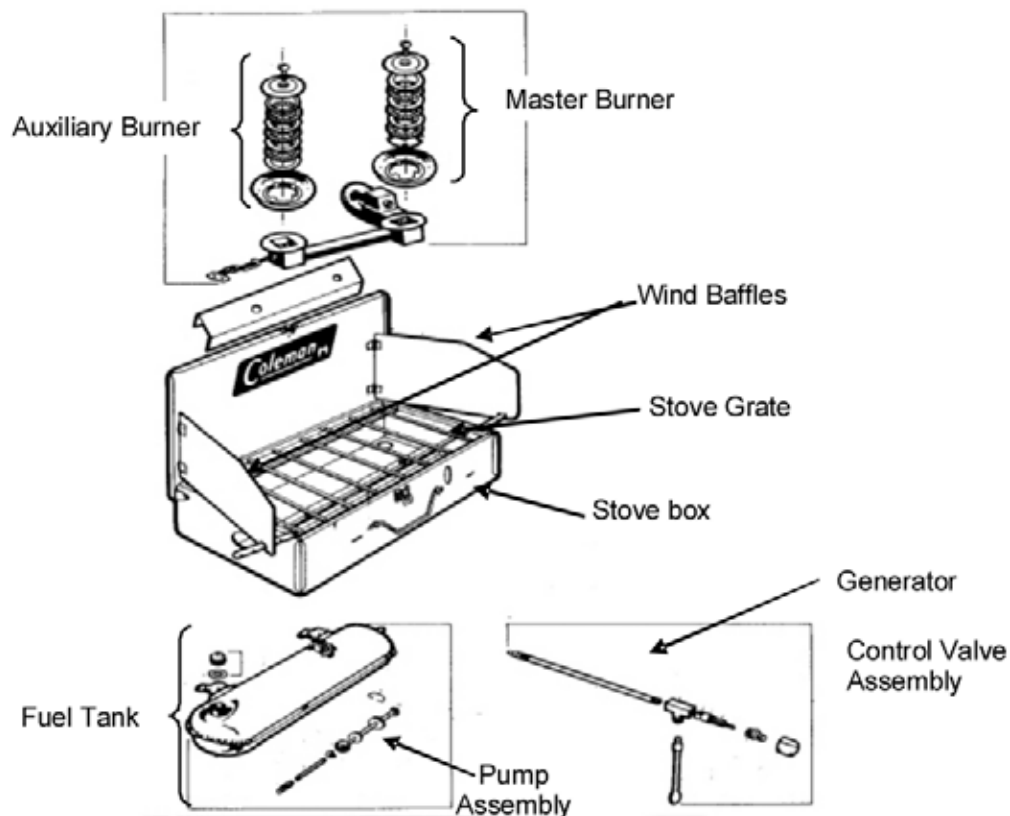

Figure 1 Parts of the Coleman Two-Burner Stove

*Note. From Basic Cold Weather Training, Arctic and Sub Arctic Operations (Vol. 2) (p.2-75), 1982, Ottawa, ON: Department of National Defence. Copyright 1982 by Department of National Defence.*

**Stove box.** This is the container in which the burners are mounted. The fuel tank and generator assembly are also stored here when the stove is disassembled for storage.

**Control valve assembly.** This consists of the main valve wheel, auxiliary value, nut and body. Its function is to regulate the flow of pressurized fuel from the fuel tank through the generator to the burner head. It remains attached to the fuel tank.

**Master Burner.** The master burner head is located on the right (or left, depending on make / model) of the stove and consists of a burner cap and a small screw with a series of burner rings. The entire assembly sits in a large burner bowl. The master burner control knob is located on the valve and generator assembly.

**Auxiliary burner.** The auxiliary burner head is located on the left (or right, depending on make / model) of the stove and consists of a burner cap and small screw along with a series of small burner rings. The entire assembly sits in a small burner bowl. The auxiliary burner control valve is located on the left (right) side of the stove box.

**Pump assembly.** The pump assembly is fitted into the tank and is held in place by a pump cap clip.

**Fuel tank.** The fuel tank is red in colour. The tank fits on the front of the stove box when in use.

**Wind baffles.** The wind baffles shelter the burners from the wind.

**Stove grate.** The stove grate supports cookware.

**Generator.** The generator supplies fuel to the burners. Fuel passing through the generator is heated by the master burner.

### Precautions

Hazards are few if precautions are taken. Follow these simple rules:

- Never leave a lit stove unattended.
- Do not use a stove as a heating device or in an enclosed space.
- Never remove the fuel tank or loosen the filler cap on the fuel tank while the stove is in operation.
- Always fill and light the stove outside in a well ventilated area, away from open flame, heat and combustibles.
- Use only naphtha fuel.
- Store away from open flame or excessive heat.
- Always ensure wind baffles and lid supports are securely positioned before lighting the stove.
- Before transporting or storing, ensure the stove is cool. Loosen the filler cap to release the air pressure and retighten. Turn the control knob off. Ensure pump valve is closed.
- If the stove catches fire, turn off the fuel supply, close the wind baffles and drop the stove lid.
- When removing the fuel tank to be refilled, remember that the generator gets HOT when the stove is operated. Allow the generator to cool before refilling the fuel tank.
- When using the stove ensure that a fire extinguisher is readily available.



It is important to stress to cadets that stoves and lanterns should not be used in enclosed spaces such as buildings and tents unless they are well ventilated. The burning of naphtha results in the release of carbon monoxide. Carbon monoxide is heavier than air, it therefore pools in the bottoms of buildings and tents, where cadets usually sleep. It will not dissipate, even for days, unless it is forced out by a strong, persistent, direct draft of cold air at floor / ground level. Carbon monoxide can kill.

---

### CONFIRMATION OF TEACHING POINT 1

#### QUESTIONS:

- Q1. What type of fuel is used?
- Q2. What is the purpose of the generator?
- Q3. Why should you only operate a stove in a well ventilated place?

#### ANTICIPATED ANSWERS:

- A1. Naphtha. (Note: also known as white gas, camping fuel and Coleman fuel.)
- A2. The generator supplies fuel to the burners. Fuel passing through the generator is heated by the master burner.

- A3. The burning of naphtha results in the release of carbon monoxide. Carbon monoxide is heavier than air, it therefore pools in the bottoms of buildings and tents, where cadets usually sleep. It will not dissipate, even for days, unless it is forced out by a strong, persistent, direct draft of cold air at floor / ground level. Carbon monoxide can kill.

## Teaching Point 2

## Identify the characteristics of a dual-mantle naphtha lantern.

Time: 5 min

Method: Interactive Lecture

### CHARACTERISTICS

Dual-mantle lanterns are designed to burn naphtha. This fuel is pressurized in a tank attached to the unit, heated in a generator and then burned as a gas.



A lit lantern produces heat. Flammable materials should be kept a minimum of 60 cm above and 30 cm from all sides of the lantern.

### Parts and Accessories



Figure 2 Coleman Dual-Mantle Lantern

*Note.* Created by Director Cadets 3, 2007, Ottawa, ON: Department of National Defence.

**Ventilator.** Allows for heat and exhaust to evacuate the lantern.

**Generator.** Provides pressurized fuel to the mantle.

**Mantle.** Emits a bright light by the burning naphtha fuel.

**Handle.** Allows the user to carry or hang the lantern.

**Pyrex globe.** Protects the mantle from foreign debris. The globe also reduces the amount of oxygen entering the lantern.

**Fuel cap.** Seals the fuel tank.

**Control knob.** Controls the amount of fuel entering the generator, controlling the brightness of the lantern.

**Tank.** Is a fuel storage reservoir.

**Pump.** Pumps air into the fuel tank, pressurizing the tank.

### **Precautions**

Hazards are few when precautions are taken. The following simple rules should be used:

- Never leave a lit lantern unattended.
- Do not use a lantern as a heating device or in an enclosed space.
- Never loosen the filler cap on the fuel tank while the lantern is in operation.
- Always fill and light the lantern outside in a well ventilated area, away from open flame, heat and combustibles.
- Use only naphtha fuel.
- Store away from open flame or excessive heat.
- If the lantern catches fire, turn off the fuel supply and let the excess fuel burn off.
- When using the lantern ensure that a fire extinguisher is readily available.
- The ventilator is HOT when lantern is lit.
- If hung by the handle while the lantern is lit, the handle is HOT.
- Mantles should be regularly checked for holes (replace if found).

---

### **CONFIRMATION OF TEACHING POINT 2**

#### **QUESTIONS:**

- Q1. What does the mantle do?
- Q2. What does the pump on the lantern do?
- Q3. When a lit lantern is hung, what should you keep in mind about the handle?

#### **ANTICIPATED ANSWERS:**

- A1. It emits a bright light by the burning naphtha fuel.
- A2. It pumps air into the fuel tank, pressurizing the tank.
- A3. If hung by the handle while the lantern is lit, the handle is HOT.



**Teaching Point 3****Explain, demonstrate and have the cadets fill and drain a stove and a lantern, utilizing a drip pan.**

Time: 15 min

Method: Demonstration and Performance



For this skill, it is recommended that instruction take the following format:

1. Explain and demonstrate the complete skill while cadets observe.
2. Explain and demonstrate each step required to complete the skill. Monitor cadets as they imitate each step.
3. Monitor the cadets' performance as they practice the complete skill.

Note: Assistant instructors may be employed to monitor the cadets' performance.



Stoves and lanterns must be cool to the touch before filling or draining.

**Filling a Stove**

The steps to fill a two-burner stove tank are as follows:

1. Ensure main valve wheel is closed.
2. Close pump knob firmly.
3. Remove fuel cap.
4. Insert funnel.
5. Ensure fuel tank is level.
6. Fill with clean, fresh fuel until the level reaches the bottom of the fill hole.
7. Remove funnel, ensuring any spills / overflow fall into the drip pan.
8. Replace fuel cap.

**Filling a Lantern**

The steps to fill a dual-mantle lantern are as follows:

1. Ensure control valve is closed.
2. Close pump knob firmly.
3. Remove fuel cap.
4. Insert funnel.
5. Ensure lantern is level.
6. Fill with clean, fresh fuel until the level reaches the bottom of the fill hole.

7. Remove funnel, ensuring any spills / overflow fall into the drip pan.
8. Replace fuel cap.

### **Draining a Stove**

The steps to drain a two-burner stove tank are as follows:

1. Ensure main valve wheel is closed.
2. Close pump knob firmly.
3. Remove fuel cap.
4. Insert funnel into fuel storage container.
5. Slowly and carefully pour fuel from tank into the funnel, ensuring any spills / overflow fall into the drip pan.
6. Replace fuel cap.

### **Draining a Lantern**

The steps to drain a dual-mantle lantern are as follows:

1. Ensure control valve is closed.
2. Close pump knob firmly.
3. Remove fuel cap.
4. Insert funnel into fuel storage container.
5. Slowly and carefully pour fuel from lantern into the funnel, ensuring any spills / overflow fall into the drip pan.
6. Replace fuel cap.

---

### **CONFIRMATION OF TEACHING POINT 3**

The cadets' participation in filling and draining a stove and a lantern will serve as the confirmation of this TP.

---

#### **Teaching Point 4**

**Explain, demonstrate and have the cadets operate a two-burner naphtha stove.**

Time: 15 min

Method: Demonstration and Performance



For this skill, it is recommended that instruction take the following format:

1. Explain and demonstrate the complete skill while cadets observe.
2. Explain and demonstrate each step required to complete the skill. Monitor cadets as they imitate each step.
3. Monitor the cadets' performance as they practice the complete skill.

Note: Assistant instructors may be employed to monitor the cadets' performance.

## ASSEMBLING

To assemble a two-burner stove:

1. Unlatch and open the stove (as per Figure 3).
2. Open and secure the wind baffles (as per Figure 4).
3. Lift the grate and remove the fuel tank (as per Figure 5).
4. Install the fuel tank. Ensure the generator passes through the large hole in the front of the stove and is inserted into the opening in the mixing chamber above the burner. Insert hanger brackets on the tank into the slots located on the front of the stove case (as per Figure 5).
5. Secure the safety chain (as per Figure 6).
6. Close the grate (as per Figure 7).
7. Ensure the auxiliary burner valve is in the closed position (as per Figure 8).



Figure 3 Closed Stove

*Note.* Created by Director Cadets 3, 2007, Ottawa, ON: Department of National Defence.



Figure 4 Wind Baffles

*Note.* Created by Director Cadets 3, 2007, Ottawa, ON: Department of National Defence.



Figure 5 Installing the Fuel Tank

Note. Created by Director Cadets 3, 2007, Ottawa, ON: Department of National Defence.



Figure 6 Securing the Safety Chain

Note. Created by Director Cadets 3, 2007, Ottawa, ON: Department of National Defence.



Figure 7 Closed Gate

Note. Created by Director Cadets 3, 2007, Ottawa, ON: Department of National Defence.



Figure 8 Auxiliary Burner Control

*Note.* Created by Director Cadets 3, 2007, Ottawa, ON: Department of National Defence.

## LIGHTING AND EXTINGUISHING



The stove fuel tank should have been fuelled previous to this lesson; however, it should not be pressurized.

### Pressurizing the Fuel Tank

1. Make sure the control knob is in the OFF position.
2. Turn the pump rod two full turns counter-clock wise (as per Figure 9).
3. Place the thumb over the air vent of the pump rod handle (as per Figure 9).
4. Pump 30–40 full strokes to pressurize the fuel tank.
5. Turn the pump rod clockwise until it is closed tight (as per Figure 9).

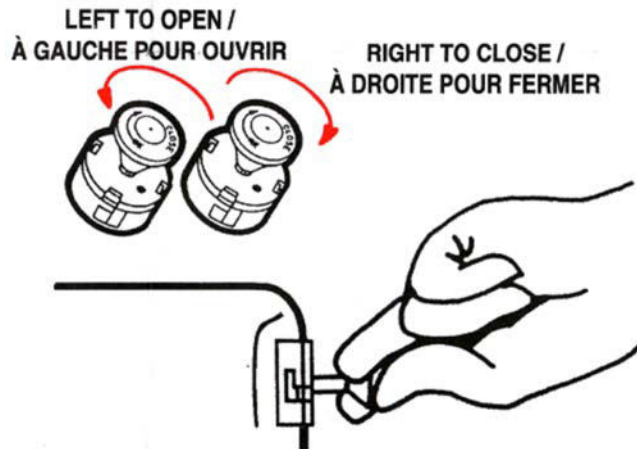

Figure 9 Pressurizing the Fuel Tank

*Note.* From *Coleman Camp Stove Model M425F710C Instructions for use*, by The Canadian Coleman Co., Mississauga, ON: The Coleman Company, Inc.

### Lighting the Master Burner



During colder conditions, it may be necessary to warm the generator prior to lighting. This can be accomplished by applying a small amount of fuel to the master burner directly and lighting it with a match. The burning fuel will heat the generator, heating the fuel inside and facilitating the lighting of the burner. When the generator is not adequately heated it is possible for liquid fuel to pool in the stove which is very dangerous.

1. Ensure the auxiliary valve is in the closed position and the tank is pumped.
2. Do not lean over the stove while lighting.
3. Hold a lit match near the master burner (as per Figure 10).
4. Turn the instant light lever to the UP TO LIGHT position (as per Figure 10).
5. Turn the main valve control knob to the LIGHT position or setting.
6. Monitor the flame.
7. When the flame turns blue in colour (approximately one minute), turn the instant light lever to the DOWN TO BURN position and turn the control knob to the desired heat setting (HI – LO).

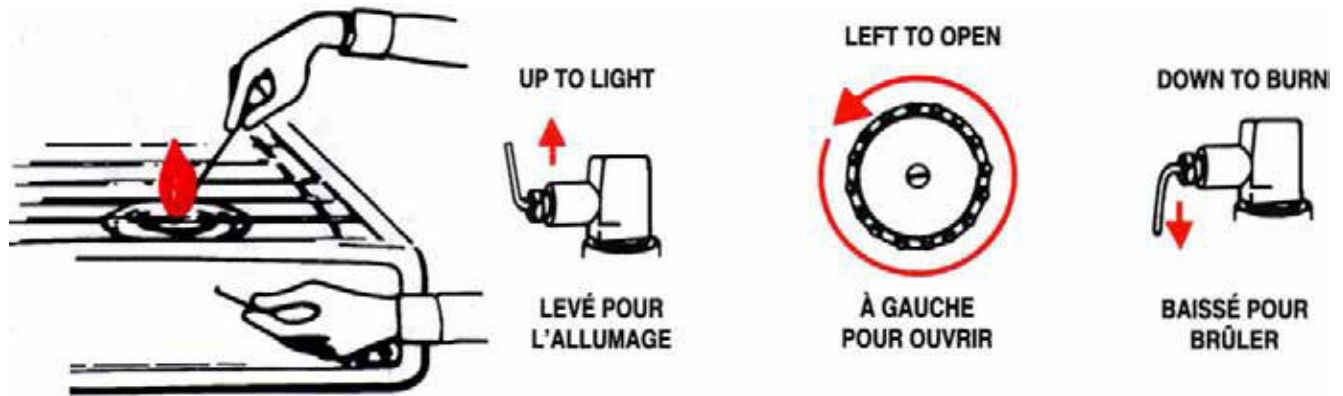
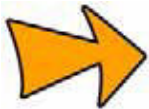

Figure 10 Lighting the Master Burner

*Note.* From *Coleman Camp Stove Model M425F710C Instructions for use*, by The Canadian Coleman Co., Mississauga, ON: The Coleman Company, Inc.



Should the stove fail to light or the match goes out before ignition, turn the control knob to the OFF position and wait two minutes before attempting to light the stove again.

### Lighting the Auxiliary Burner

1. After the master burner has been lit, the auxiliary burner may be lit.
2. Hold a match to the auxiliary burner. Open the auxiliary valve located on the side of the stove box, next to the burner (the master burner may require adjustment after lighting the auxiliary burner).

### Extinguishing the Burner

1. Close the auxiliary burner valve.
2. Remove cookware from the stove and turn the instant light lever up to LIGHT position and let burn for one minute. This cleans heavier parts of fuel from the generator.
3. Turn the main valve control knob clockwise to the OFF position and close firmly.



A small flame on the master burner will continue to burn for a few minutes, until the fuel empties from the generator.

### DISASSEMBLING AFTER USE

To store a two-burner stove:

1. Allow the stove to cool before packing.
2. Ensure the stove is clean and any dirt, matches, etc. are emptied from the stove box.
3. Ensure the auxiliary burner valve is in the closed position.
4. Open the grate.
5. Remove the safety chain.



6. Uninstall the fuel tank and remove it from the stove box.
7. Unpressurize the fuel tank by loosening the filler cap, then retighten it to reseal the fuel tank. Note: Angle the fuel tank so that the filler cap is highest to reduce possible fuel leakage.
8. Place the fuel tank inside the stove box.
9. Close the grate.
10. Close and fold in the wind baffles.
11. Close the cover and latch the box.

---

#### CONFIRMATION OF TEACHING POINT 4

The cadets' participation in operating a stove will serve as the confirmation of this TP.

---

#### Teaching Point 5

**Explain, demonstrate and have the cadets operate a dual-mantle naphtha lantern.**

Time: 20 min

Method: Demonstration and Performance

---



For this skill, it is recommended that instruction take the following format:

1. Explain and demonstrate the complete skill while cadets observe.
2. Explain and demonstrate each step required to complete the skill. Monitor cadets as they imitate each step.
3. Monitor the cadets' performance as they practice the complete skill.

Note: Assistant instructors may be employed to monitor the cadets' performance.

#### ASSEMBLING

The lantern does not require assembly or disassembly except when replacing the mantles / globe. Before operating the lantern, the cadet should verify that the handle is in place and that the ball nut (screw on top of the ventilator) is tight.

#### LIGHTING AND EXTINGUISHING



The lantern should have been fuelled previous to this lesson; however, the lantern should not be pressurized. When a mantle is replaced it should be burned prior to use. By burning the mantle, the mantle shrinks down in size ensuring that combustion of the fuel takes place at the mantle. When the mantle is not burned prior to use fuel can leak out of the mantle prior to combustion.

#### Pressurizing the Fuel Tank

1. Make sure the control knob is in the OFF position.
2. Turn the pump rod two full turns counter-clockwise.
3. Place the thumb over the air vent of the pump rod handle.



4. Pump 30–40 full strokes to pressurize the fuel tank.
5. Turn the pump rod to clockwise until it is closed tight.

### Lighting the Lantern



Do not position the hands or head above the lantern when lighting.

Mantles are very fragile and shall be avoided when using a match to light the lantern.

1. Insert a lit match through the hole in the bottom of the burner frame.
2. Turn the control knob to the LIGHT position.
3. When the mantle burns bright white (after about one minute), turn the control knob to the ON position.
4. Add more air pressure to the tank. Air pressure may be added while the lantern is in operation. Good air pressure is important for maximum light output.

### Extinguishing the Lantern

1. Turn the control knob to the OFF position.
2. Allow the remaining fuel to burn off.

### STORING AFTER USE

To store a dual-mantle lantern:

1. Ensure the lantern is cool.
2. Wipe and clean away any dirt.
3. Drain the fuel into a fuel storage container (do not drain as the lantern is required for the other groups to use).
4. Place in a cool, dry location.

---

### CONFIRMATION OF TEACHING POINT 5

The cadets' participation in operating a lantern will serve as the confirmation of this TP.

**Teaching Point 6****Explain, demonstrate and have the cadets perform minor maintenance on a stove and lantern.**

Time: 15 min

Method: Demonstration and Performance



For this skill, it is recommended that instruction take the following format:

1. Explain and demonstrate the complete skill while cadets observe.
2. Explain and demonstrate each step required to complete the skill. Monitor cadets as they imitate each step.
3. Monitor the cadets' performance as they practice the complete skill.

Note: Assistant instructors may be employed to monitor the cadets' performance.

**PERFORM MINOR MAINTENANCE**

Stoves and lanterns must be cool to the touch before performing cleaning and any minor maintenance.

**Cleaning the Stove**

Clean as needed during a field exercise and before storage.

- Fuel tank should be wiped using fresh naphtha as the solvent.
- The burner assemblies should have the remains of matches and food residue (Note: Flame usually burns yellow instead of blue where there are remains and residue).
- Stove box should be washed with soap and water to remove food residue and grease.



The burner assemblies should not be immersed in water as any water left in the tubes will cut-off or restrict the flow of fuel. Burner assemblies should be removed from the stove box and cleaned separately if the stove box is being immersed to be cleaned.

**Cleaning the Lantern**

Clean as needed during a field exercise and before storage.

- Fuel tank and ventilator should be wiped using fresh naphtha as the solvent.
- Remains of matches should be removed from inside the globe.
- Globe should be carefully cleaned and dried.

**Replacing a Mantle**

If a mantle has fallen apart or has a hole in it, it should be replaced before operating the lantern.

1. Remove handle by pulling the handle arms gently away from the lantern.
2. Unscrew and remove the ball nut.

3. Remove the ventilator.
4. Remove the globe.
5. Only use the appropriate mantle for the lantern.
6. Remove the remains of the old mantle.
7. Tie mantle around the grooves in the burner cap, with the flat side of the mantle facing the generator (as per Figure 11).
8. Cut off excess string.
9. Light bottom of the mantle evenly, burning until nothing but ash is left.
10. Allow mantle to cool before lighting the lantern.
11. Reassemble the lantern.

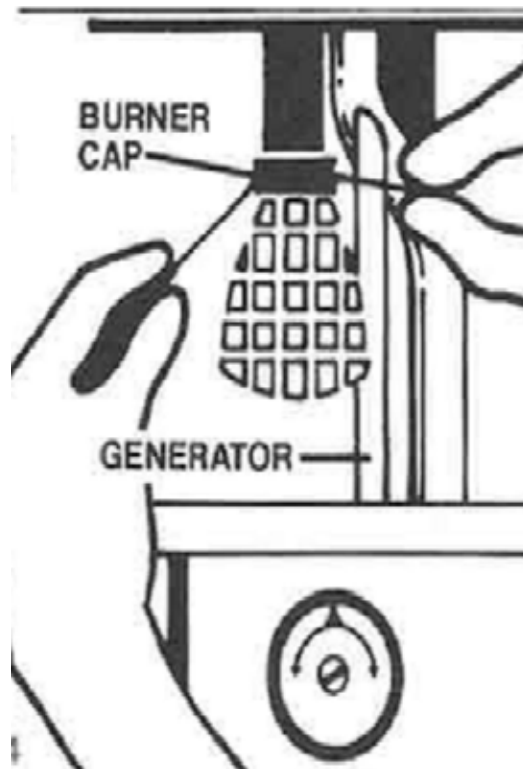

Figure 11 Replacing a Mantle

*Note. From Coleman Lantern Model 220K195 & 228K195 How To Use and Enjoy, by The Canadian Coleman Co., Toronto, ON: The Coleman Company, Inc.*

### **Inspecting the Pump Assembly**

1. Remove clip from pump cap using needle-nose pliers (as per Figure 12).
2. Turn pump knob counter clockwise several times to unscrew air stem.
3. Pull out pump and air stem (as per Figure 12).
4. Examine pump leather, if dry, work several drops of oil into it.

5. Insert pump and air stem into tank (pump leather must not invert or fold).
6. Replace pump cap and clip.
7. Turn pump knob clockwise several times to screw air stem into the tank.

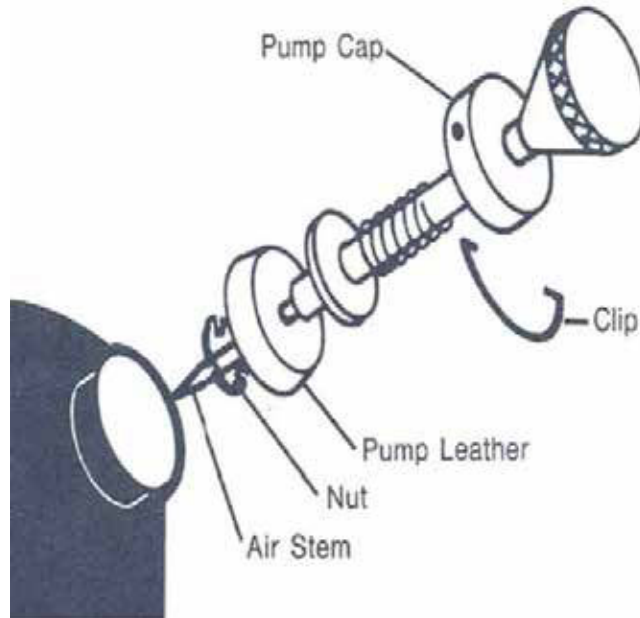

Figure 12 Pump Assembly

*Note. From Coleman Lantern Model 220K195 & 228K195 How To Use and Enjoy, by The Canadian Coleman Co., Toronto, ON: The Coleman Company, Inc.*

---

#### **CONFIRMATION OF TEACHING POINT 6**

The cadets' participation in performing minor maintenance will serve as the confirmation of this TP.

---

#### **END OF LESSON CONFIRMATION**

The cadets' filling and draining, operating and performing minor maintenance on a two-burner stove and a dual-mantle lantern will serve as confirmation of this lesson.

---

#### **CONCLUSION**

---

#### **HOMEWORK / READING / PRACTICE**

Nil.

#### **METHOD OF EVALUATION**

This EO is assessed IAW A-CR-CCP-804/PG-001, *Proficiency Level Four Standard and Plan*, Chapter 3, Annex B, 490 PC.

#### **CLOSING STATEMENT**

Knowing how to operate a stove and a lantern will give the cadets the skills needed to help support survival training during field exercises.

**INSTRUCTOR NOTES / REMARKS**

The spill response kit will be at the fuelling area.

Refer to the manuals for all operations and maintenance of the two-burner naphtha stove and dual-mantle naphtha lantern.

A fire extinguisher will be at each site where stoves and lanterns are being lit.

When cleaning the stove, the fuel tank is to be wiped with fresh naphtha. Protective gloves and clothing are to be worn when completing this task. Acceptable materials for gloves are neoprene, nitrile / viton. It is also recommended that safety glasses, splash goggles, or face shield be worn. Have eye water wash available.

Cadets who are qualified Survival Instructor may assist with this instruction.

---

**REFERENCES**

---

Manuals for stove and lantern types being used.

THIS PAGE INTENTIONALLY LEFT BLANK



**ROYAL CANADIAN AIR CADETS**  
**PROFICIENCY LEVEL FOUR**  
**INSTRUCTIONAL GUIDE**



**SECTION 3**

**EO M490.03 – TIE KNOTS AND LASHINGS**

---

Total Time:	60 min
-------------	--------

---

**PREPARATION**

---

**PRE-LESSON INSTRUCTIONS**

Resources needed for the delivery of this lesson are listed in the lesson specification located in A-CR-CCP-804/PG-001, *Proficiency Level Four Qualification Standard and Plan*, Chapter 4. Specific uses for said resources are identified throughout the instructional guide within the TP for which they are required.

Review the lesson content and become familiar with the material prior to delivering the lesson.

Photocopy the knot-tying and lashing instructions located at Attachments A and B for each cadet.

Cut lengths of braided rope for the cadets to tie the knots. The rope should be 10 mm (3/8 inch) in diameter and 3 m (10 feet) in length. Each cadet will require two lengths of rope.

Collect poles from natural resources. Poles should be approximately 2 m in length and 6 cm in diameter. Each cadet will require two poles.

**PRE-LESSON ASSIGNMENT**

Nil.

**APPROACH**

An interactive lecture was chosen for TP 1 to present background material on rope terminology.

A demonstration and performance was chosen for TPs 2 and 3 as it allows the instructor to explain and demonstrate tying knots and lashings while providing an opportunity for the cadets to practice and develop these skills under supervision.

---

**INTRODUCTION**

---

**REVIEW**

Nil.

**OBJECTIVES**

By the end of this lesson the cadet shall have tied knots and lashings.

**IMPORTANCE**

It is important for the cadets to know how to tie different knots and lashings in order to construct sturdy shelters, tents, snares and camp crafts.

**Teaching Point 1****Describe the parts of a rope.**

Time: 10 min

Method: Interactive Lecture

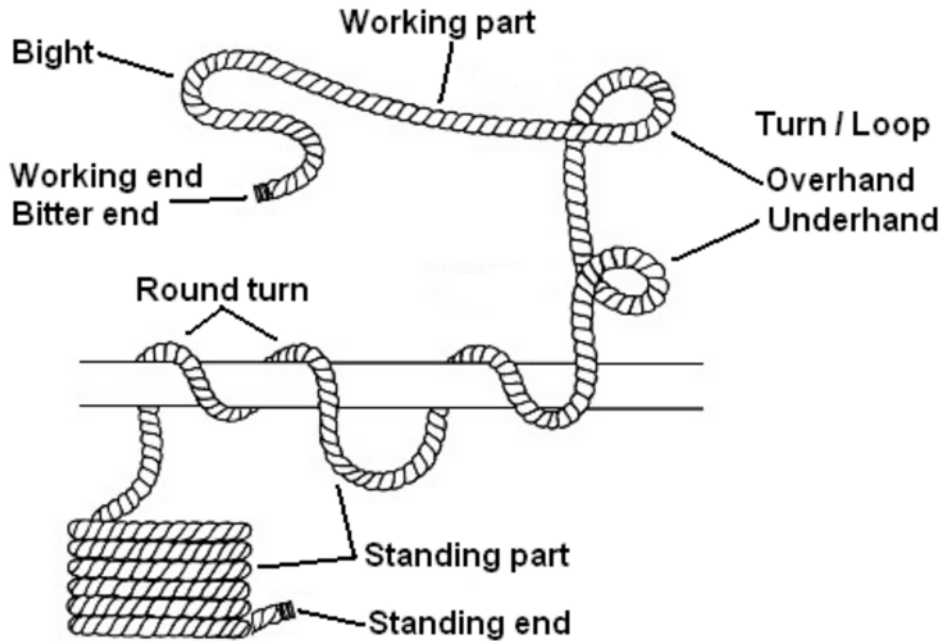

Figure 1 Parts of a Rope

*Note.* From *Lost Knowledge Site*, by B. Green. 2006. Retrieved March 6, 2009, from <http://lostknowledgesite.com/BackToBasics/Knots/Knots.html>

**PARTS OF A ROPE**

The following definitions will assist cadets when tying each knot or lashing:

**Working end (Bitter end).** The very end of the rope that is used for tying a knot.

**Working part (Running part).** is the short length of rope that is manipulated to make the knot.

**Standing end.** The end of the rope opposite the end being used for tying a knot.

**Standing part.** The section of rope that usually “stands still” during the knot-tying process. Often it is the longer end that leads away from the loop, bight or knot.

**Turn or Loop.** A part of rope that crosses over itself. The working part can be over or under the standing part in a crossing turn.

**Bight.** A loop in the rope that does not cross over itself.



---

**CONFIRMATION OF TEACHING POINT 1****QUESTIONS:**

- Q1. What part of the rope is called the working part?
- Q2. What is a bight?
- Q3. What is the standing end?

**ANTICIPATED ANSWERS:**

- A1. The working part (running part) is the short length of rope that is manipulated to make the knot.
- A2. A bight is a loop in the rope that does not cross over itself.
- A3. The standing end is the end of the rope opposite the end being used for tying a knot.

---

**Teaching Point 2****Explain, demonstrate and have the cadets tie knots.**

Time: 20 min

Method: Demonstration and Performance



For this skill lesson, it is recommended that the instructor take the following format:

1. Explain and demonstrate the complete knot while cadets observe.
2. Explain and demonstrate each step required to complete the knot. Monitor cadets as they imitate each step.
3. Monitor the cadets' performance as they practice the complete knot.

Note: Assistant instructors may be used to monitor the cadets' performance.

**KNOTS**

**Reef knot.** The reef knot is used for joining two ropes of equal diameter together. This knot can hold a moderate amount of weight and is ideal for first aid. It may be used when tying slings because the knot lies flat against the body.

## Steps for Tying a Reef Knot

1. Place the left-hand working end on the top of the right-hand working end.

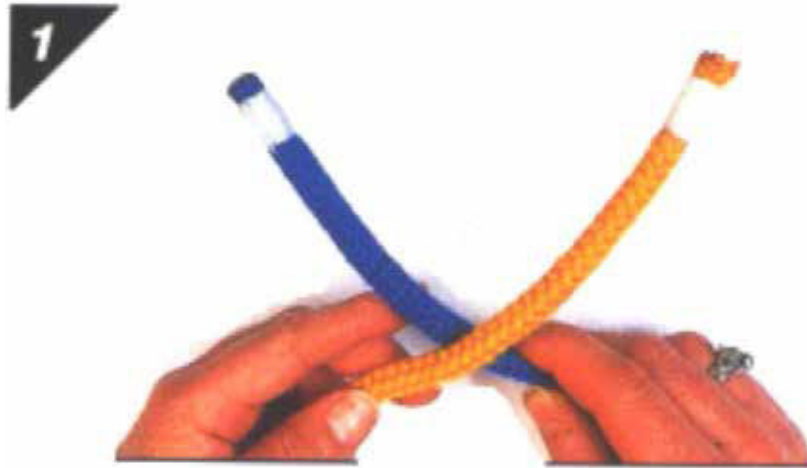

Figure 2 Step 1

*Note.* From *Pocket Guide to Knots and Splices* (p. 98), by D. Pawson, 2001, London, England: Prospero Books Inc. Copyright 2001 by PRC Publishing Ltd.

2. Bring the left-hand working end under the right-hand working end.



Figure 3 Step 2

*Note.* From *Pocket Guide to Knots and Splices* (p. 98), by D. Pawson, 2001, London, England: Prospero Books Inc. Copyright 2001 by PRC Publishing Ltd.

3. Place the working end that is now on the right, on top of the working end that is now on the left.



Figure 4 Step 3

*Note.* From *Pocket Guide to Knots and Splices* (p. 98), by D. Pawson, 2001, London, England: Prospero Books Inc. Copyright 2001 by PRC Publishing Ltd.

4. Bring the working end that is on top under the other working end so it comes out at the same place it entered the knot.



Figure 5 Step 4

*Note.* From *Pocket Guide to Knots and Splices* (p. 98), by D. Pawson, 2001, London, England: Prospero Books Inc. Copyright 2001 by PRC Publishing Ltd.

5. Pull tight to complete the reef knot.



Figure 6 Step 5

*Note.* From *Pocket Guide to Knots and Splices* (p. 98), by D. Pawson, 2001, London, England: Prospero Books Inc. Copyright 2001 by PRC Publishing Ltd.

**Figure-of-eight knot.** The figure-of-eight knot is very simple and quick to tie. It makes an ideal stopper knot and is very easy to untie.

#### Steps for Tying a Figure-of-Eight Knot

1. Make a crossing turn with the working end passing under the standing part of the rope and then bring the working end over the standing part.



Figure 7 Step 1

*Note.* From *Pocket Guide to Knots and Splices* (p. 44), by D. Pawson, 2001, London, England: Prospero Books Inc. Copyright 2001 by PRC Publishing Ltd.

2. Now tuck the working end up through the loop from behind, forming a figure-of-eight.



Figure 8 Step 2

*Note.* From *Pocket Guide to Knots and Splices* (p. 44), by D. Pawson, 2001, London, England: Prospero Books Inc. Copyright 2001 by PRC Publishing Ltd.

3. Pull tight to complete the figure-of-eight knot.



Figure 9 Step 3

*Note.* From *Pocket Guide to Knots and Splices* (p. 44), by D. Pawson, 2001, London, England: Prospero Books Inc. Copyright 2001 by PRC Publishing Ltd.

**Clove hitch.** The clove hitch consists of two half hitches or crossing turns each made in the same direction. It is used to finish and start lashings and should not be used in a situation where the hitch has variable tension as it can work loose.

### Steps for Tying a Clove Hitch

1. Make a turn around a pole / tree bringing the working end of the rope over and trapping the standing part of the rope. This makes the first half hitch.

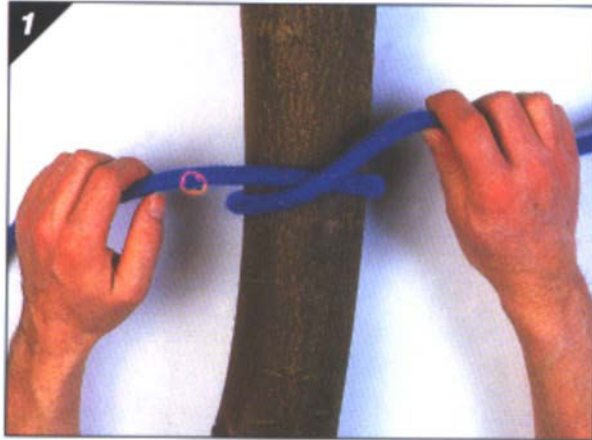

Figure 10 Step 1

*Note.* From *Pocket Guide to Knots and Splices* (p. 106), by D. Pawson, 2001, London, England: Prospero Books Inc. Copyright 2001 by PRC Publishing Ltd.

2. Bring the working end behind the pole / tree, above the first half hitch.



Figure 11 Step 2

*Note.* From *Pocket Guide to Knots and Splices* (p. 106), by D. Pawson, 2001, London, England: Prospero Books Inc. Copyright 2001 by PRC Publishing Ltd.

- Put the working end under the turn just made. This gives the second half hitch and forms the clove hitch.



Figure 12 Step 3

*Note.* From *Pocket Guide to Knots and Splices* (p. 106), by D. Pawson, 2001, London, England: Prospero Books Inc. Copyright 2001 by PRC Publishing Ltd.

- Pull tight to complete the clove hitch.



Figure 13 Step 4

*Note.* From *Pocket Guide to Knots and Splices* (p. 106), by D. Pawson, 2001, London, England: Prospero Books Inc. Copyright 2001 by PRC Publishing Ltd.

**Bowline.** The bowline is a very secure knot that will not slip, regardless of the load applied. Use this knot whenever a non-slip loop is required at the end of a line.



## Steps to Tying a Bowline

1. A short distance back from the working end, make a crossing turn with the working part on top. Go on to form the size of the loop you require.



Figure 14 Step 1

*Note.* From *Pocket Guide to Knots and Splices* (p. 163), by D. Pawson, 2001, London, England: Prospero Books Inc. Copyright 2001 by PRC Publishing Ltd.

2. Bring the working end up through the crossing turn. It will go under first, and then lie on top of the other part of the turn.



Figure 15 Step 2

*Note.* From *Pocket Guide to Knots and Splices* (p. 163), by D. Pawson, 2001, London, England: Prospero Books Inc. Copyright 2001 by PRC Publishing Ltd.



3. Bring the working end around behind the standing part and down through the crossing turn. A good way to remember this is: “the rabbit comes out of the hole, around the tree and back down the hole again”.

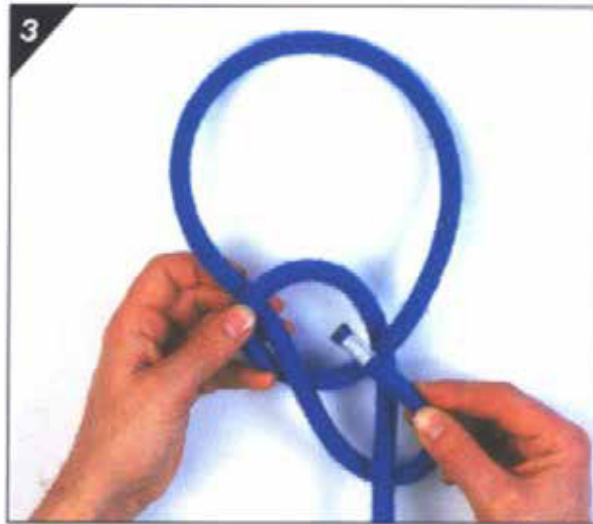

Figure 16 Step 3

*Note.* From *Pocket Guide to Knots and Splices* (p. 163), by D. Pawson, 2001, London, England: Prospero Books Inc. Copyright 2001 by PRC Publishing Ltd.

4. Pull tight by holding the working end and pulling on the standing part to complete the bowline.



Figure 17 Step 4

*Note.* From *Pocket Guide to Knots and Splices* (p. 163), by D. Pawson, 2001, London, England: Prospero Books Inc. Copyright 2001 by PRC Publishing Ltd.



Distribute Attachment A to the cadets, so they may practice the knots after the lesson.

---

## CONFIRMATION OF TEACHING POINT 2

The cadets' participation in tying knots will serve as the confirmation of this TP.

---

### Teaching Point 3

**Explain, demonstrate and have the cadets tie lashings.**

Time: 20 min

Method: Demonstration and Performance

---



For this skill, it is recommended that the instruction take the following format:

1. Explain and demonstrate the complete lashing while cadets observe.
2. Explain and demonstrate each step required to complete the lashing. Monitor cadets as they imitate each step.
3. Monitor the cadets' performance as they practice the complete lashing.

Note: Assistant instructors may be used to monitor the cadets' performance.

## LASHINGS

**Round lashing.** Sometimes called a sheer lashing, the round lashing has two distinct uses. First, it creates an "A" frame or set of using a single lashing. Second, two or three round lashings can be used to bind together a couple of poles to make a longer spar. To make an "A" frame, two poles are put side by side; the lashing is made at one end as illustrated in Figures 18–24. A slightly different approach is used to join two poles together to make a longer pole. The procedure is exactly the same, except the initial and final clove hitches are tied around both poles and there is no space left between the poles and no frapping is used. For extra strength to the spar, add extra lashings at the opposite end and middle of the adjoining poles.

### Steps to Tying a Round Lashing

1. Start by making a clove hitch around both poles.



Figure 18 Step 1

*Note.* From *Pocket Guide to Knots and Splices* (p. 184), by D. Pawson, 2001, London, England: Prospero Books Inc. Copyright 2001 by PRC Publishing Ltd.

2. Wrap around both poles, trapping the end of the clove hitch.

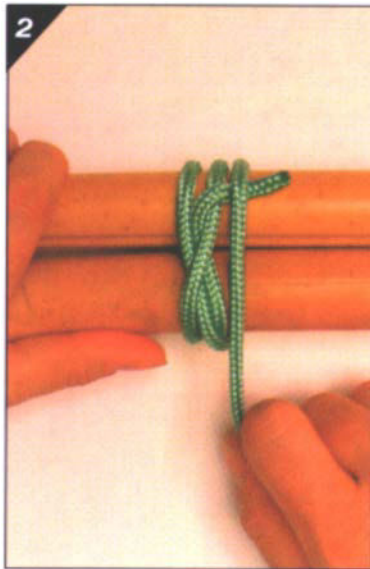

Figure 19 Step 2

*Note.* From *Pocket Guide to Knots and Splices* (p. 184), by D. Pawson, 2001, London, England: Prospero Books Inc. Copyright 2001 by PRC Publishing Ltd.

3. Carry on making eight to ten more turns round the pair of poles.



Figure 20 Step 3

*Note.* From *Pocket Guide to Knots and Splices* (p. 184), by D. Pawson, 2001, London, England: Prospero Books Inc. Copyright 2001 by PRC Publishing Ltd.

4. The lashing could now be finished with a clove hitch around both poles or put in a couple of frapping turns by bringing the end of the rope between the two poles.



Figure 21 Step 4

*Note.* From *Pocket Guide to Knots and Splices* (p. 185), by D. Pawson, 2001, London, England: Prospero Books Inc. Copyright 2001 by PRC Publishing Ltd.

5. Finish off with a clove hitch around one of the poles.



Figure 22 Step 5

*Note.* From *Pocket Guide to Knots and Splices* (p. 185), by D. Pawson, 2001, London, England: Prospero Books Inc. Copyright 2001 by PRC Publishing Ltd.

6. Pull tight to finish the round lashing with the poles parallel.

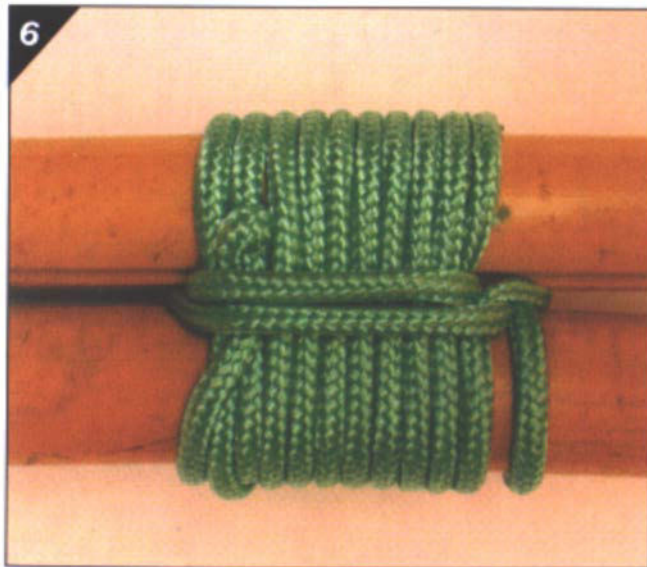

Figure 23 Step 6

*Note.* From *Pocket Guide to Knots and Splices* (p. 185), by D. Pawson, 2001, London, England: Prospero Books Inc. Copyright 2001 by PRC Publishing Ltd.

7. If being used for an "A" frame then open the poles.



Figure 24 Step 7

*Note.* From *Pocket Guide to Knots and Splices* (p. 185), by D. Pawson, 2001, London, England: Prospero Books Inc. Copyright 2001 by PRC Publishing Ltd.

**Square lashing.** A square lashing secures two poles together at 90 degrees and can be used in the construction of shelters and camp crafts. The cord used to make the lashing should be considerably smaller than the size of the poles. For the lashing to be effective, each turn must be pulled as tight as possible as it is made.

### Steps to Tying a Square Lashing

1. With the vertical pole on top of the horizontal pole, make a clove hitch on the vertical pole just below the horizontal pole.

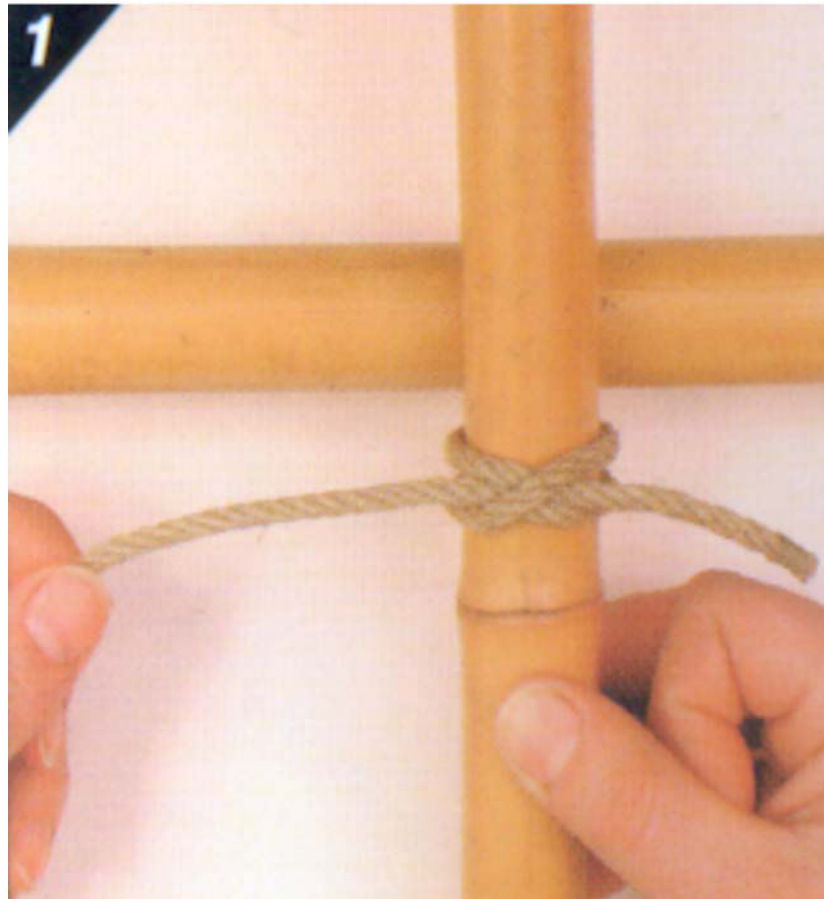

Figure 25 Step 1

*Note.* From *Pocket Guide to Knots and Splices* (p. 181), by D. Pawson, 2001, London, England: Prospero Books Inc. Copyright 2001 by PRC Publishing Ltd.



2. Bring all the cord around behind the horizontal pole.



Figure 26 Step 2

*Note.* From *Pocket Guide to Knots and Splices* (p. 181), by D. Pawson, 2001, London, England: Prospero Books Inc. Copyright 2001 by PRC Publishing Ltd.



3. Bring the cord over the vertical pole and back behind the horizontal pole to the clove hitch. Pull tight.



Figure 27 Step 3

*Note.* From *Pocket Guide to Knots and Splices* (p. 181), by D. Pawson, 2001, London, England: Prospero Books Inc. Copyright 2001 by PRC Publishing Ltd.

4. Carry on making two or three more complete turns around the two poles, pulling tight after each turn.



Figure 28 Step 4

*Note.* From *Pocket Guide to Knots and Splices* (p. 181), by D. Pawson, 2001, London, England: Prospero Books Inc. Copyright 2001 by PRC Publishing Ltd.

5. After passing the clove hitch, bring the cord around the horizontal pole from behind and start to wrap around the junction between the two poles. These are frapping turns—pull them as tight as possible.

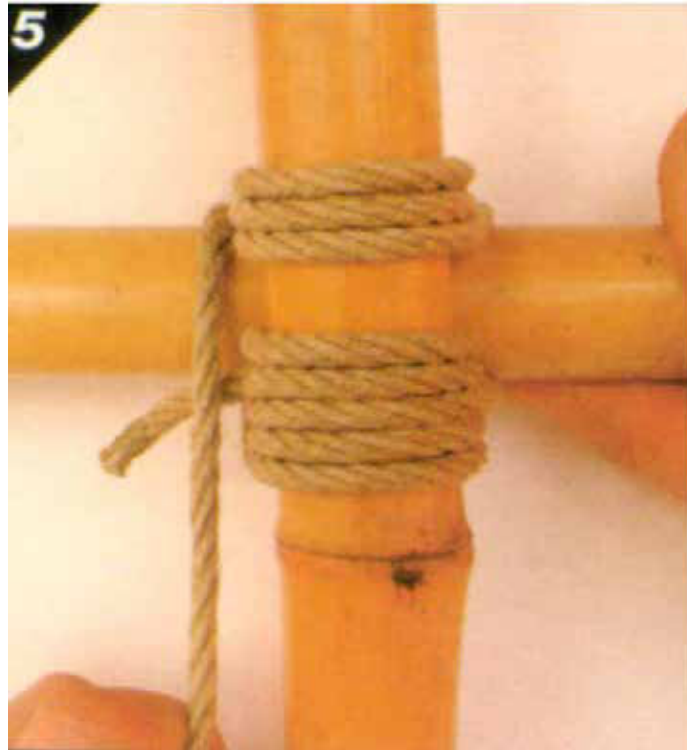

Figure 29 Step 5

*Note.* From *Pocket Guide to Knots and Splices* (p. 181), by D. Pawson, 2001, London, England: Prospero Books Inc. Copyright 2001 by PRC Publishing Ltd.

6. Make two frapping turns.



Figure 30 Step 6

*Note.* From *Pocket Guide to Knots and Splices* (p. 181), by D. Pawson, 2001, London, England: Prospero Books Inc. Copyright 2001 by PRC Publishing Ltd.

7. Finish off with a clove hitch around the horizontal pole.



Figure 31 Step 7

*Note.* From *Pocket Guide to Knots and Splices* (p. 181), by D. Pawson, 2001, London, England: Prospero Books Inc. Copyright 2001 by PRC Publishing Ltd.

8. Pull tight to complete the square lashing.



Figure 32 Step 8

*Note.* From *Pocket Guide to Knots and Splices* (p. 181), by D. Pawson, 2001, London, England: Prospero Books Inc. Copyright 2001 by PRC Publishing Ltd.

**Figure-of-eight lashing.** The figure-of-eight lashing is used to join three poles together to create a tripod. The tripod can be used for creating signal fires, shelters and camp crafts in a survival situation.

#### Steps to Lashing a Figure-of-Eight Lashing

1. Start with a clove hitch around one of the poles, and lead the rope under and over the other two poles.



Figure 33 Step 1

*Note.* From *Pocket Guide to Knots and Splices* (p. 187), by D. Pawson, 2001, London, England: Prospero Books Inc. Copyright 2001 by PRC Publishing Ltd.

2. Go around the pole furthest away from the start and weave the rope back over and under.



Figure 34 Step 2

*Note.* From *Pocket Guide to Knots and Splices* (p. 187), by D. Pawson, 2001, London, England: Prospero Books Inc. Copyright 2001 by PRC Publishing Ltd.

3. Continue to weave the rope in the figure-of-eight manner for seven or eight full passes before bringing the rope up between two of the poles.

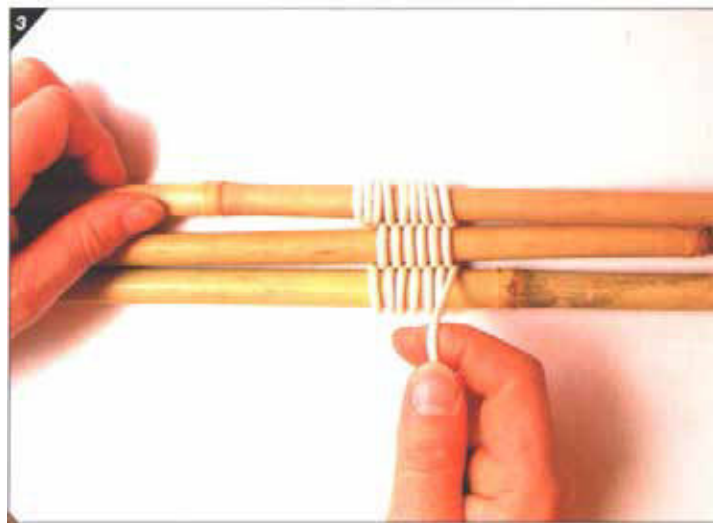

Figure 35 Step 3

*Note.* From *Pocket Guide to Knots and Splices* (p. 187), by D. Pawson, 2001, London, England: Prospero Books Inc. Copyright 2001 by PRC Publishing Ltd.

4. Pull the rope parallel to the poles and start to put in some frapping turns.

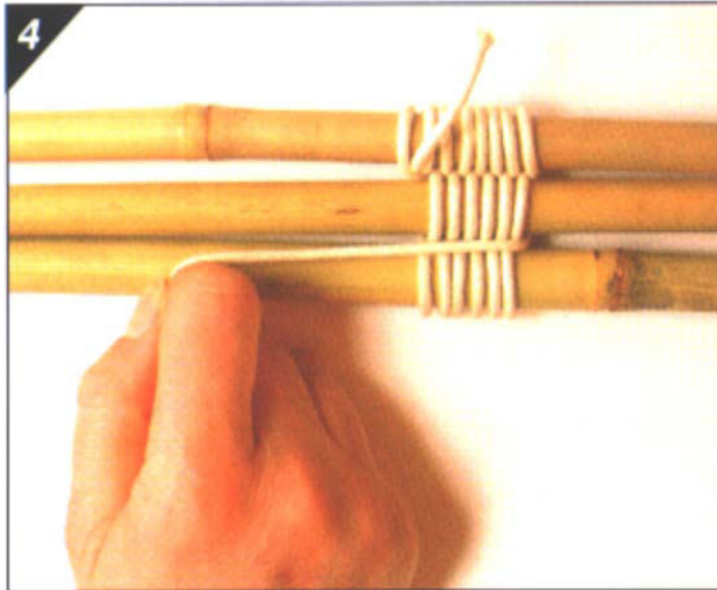

Figure 36 Step 4

*Note.* From *Pocket Guide to Knots and Splices* (p. 188), by D. Pawson, 2001, London, England: Prospero Books Inc. Copyright 2001 by PRC Publishing Ltd.

5. After making frapping turns between the first two poles move on to make frapping turns around the other pair of poles.

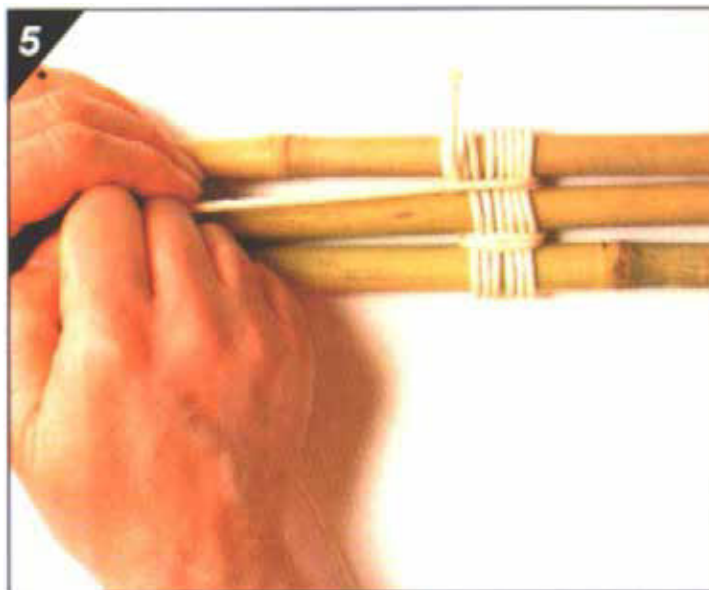

Figure 37 Step 5

*Note.* From *Pocket Guide to Knots and Splices* (p. 188), by D. Pawson, 2001, London, England: Prospero Books Inc. Copyright 2001 by PRC Publishing Ltd.



6. Finish off with a clove hitch around the pole from which you first started.

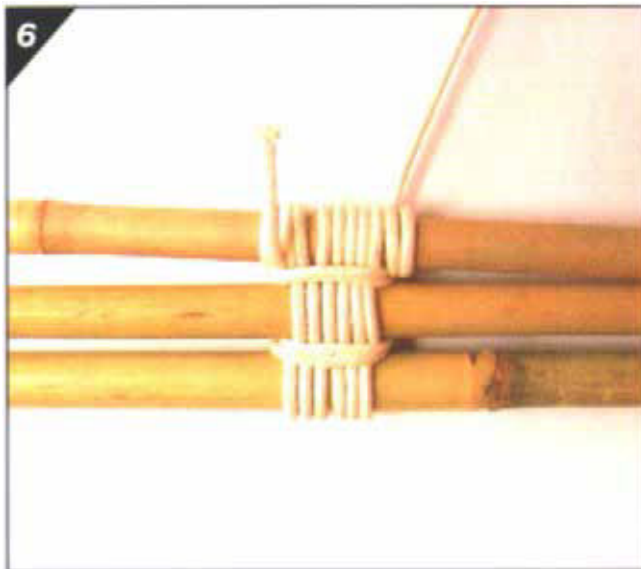

Figure 38 Step 6

*Note.* From *Pocket Guide to Knots and Splices* (p. 188), by D. Pawson, 2001, London, England: Prospero Books Inc. Copyright 2001 by PRC Publishing Ltd.

7. Open to create tripod.



Figure 39 Step 7

*Note.* From *Pocket Guide to Knots and Splices* (p. 188), by D. Pawson, 2001, London, England: Prospero Books Inc. Copyright 2001 by PRC Publishing Ltd.



Distribute Attachment B to the cadets, so they may practice the knots after the lesson.

---

### **CONFIRMATION OF TEACHING POINT 3**

The cadets' participation in tying lashings will serve as the confirmation of this TP.

---

### **END OF LESSON CONFIRMATION**

The cadets' participation in tying knots and lashing will serve as the confirmation of this lesson.

---

### **CONCLUSION**

---

### **HOMEWORK / READING / PRACTICE**

Nil.

### **METHOD OF EVALUATION**

This EO is assessed IAW A-CR-CCP-804/PG-001, *Proficiency Level Four Standard and Plan*, Chapter 3, Annex B, 490 PC.

### **CLOSING STATEMENT**

It is important for the cadets to select the appropriate knot and lashing when constructing shelters, signal fires or camp crafts for safety and quality.

### **INSTRUCTOR NOTES / REMARKS**

Cadets who are qualified Survival Instructor may assist with this instruction.

---

### **REFERENCES**

C3-026 ISBN 1-55267-218-2 Pawson, D. (2001). *Pocket guide to knots and splices*. London, England: PRC Publishing.

## KNOT-TYING INSTRUCTIONS

### REEF KNOT

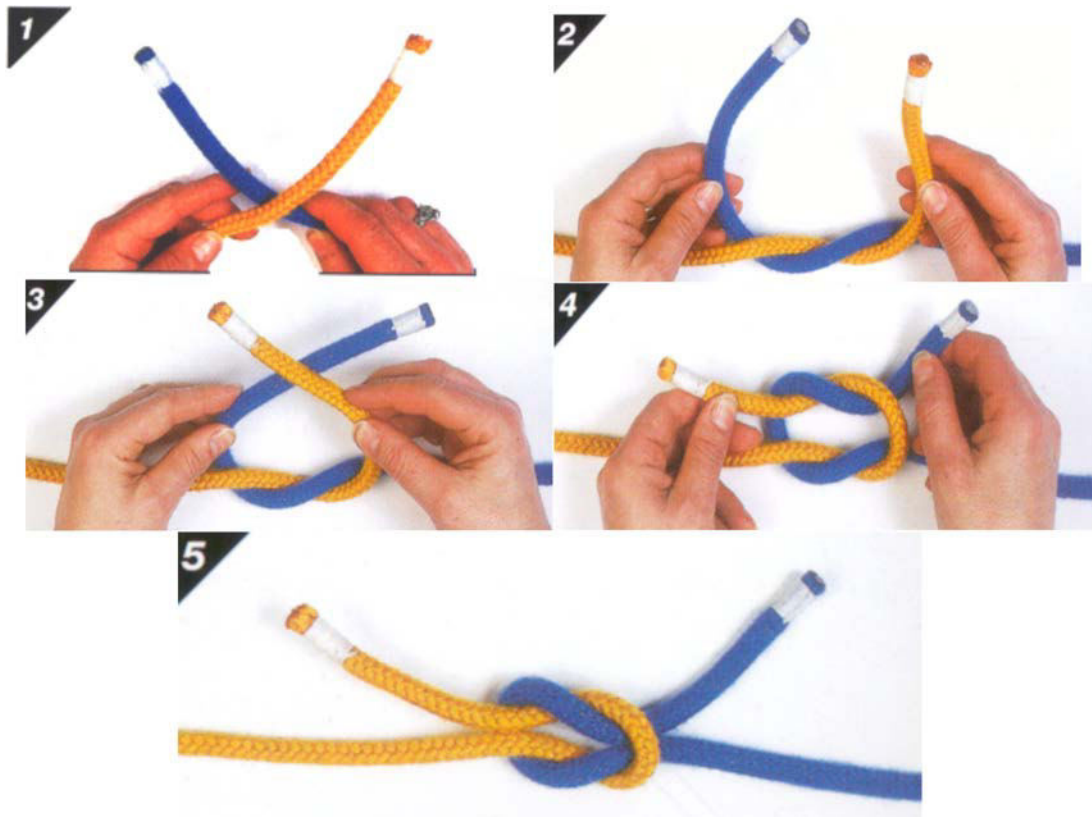

Figure A-1 Steps 1–5

*Note. From *Pocket Guide to Knots and Splices* (p. 98), by D. Pawson, 2001, London, England: Prospero Books Inc. Copyright 2001 by PRC Publishing Ltd.*

1. Place the left-hand working end on the top of the right-hand working end.
2. Bring the left-hand working end under the right-hand working end.
3. Place the working end that is now on the right on top of the working end that is now on the left.
4. Bring the working end that is on top under the other working end so that working end that is moving comes out at the same place it entered the knot.
5. Pull tight to complete the reef knot.

## KNOT-TYING INSTRUCTIONS

### FIGURE-OF-EIGHT KNOT



Figure A-2 Steps 1–3

*Note.* From *Pocket Guide to Knots and Splices* (p. 44), by D. Pawson, 2001, London, England: Prospero Books Inc. Copyright 2001 by PRC Publishing Ltd.

1. Make a crossing turn with the working end passing under the standing part of the rope and then bring the working end over the standing part.
2. Now tuck the working end up through the loop from behind, forming a figure-of-eight.
3. Pull tight to complete the figure-of-eight knot.

## KNOT-TYING INSTRUCTIONS

### CLOVE HITCH

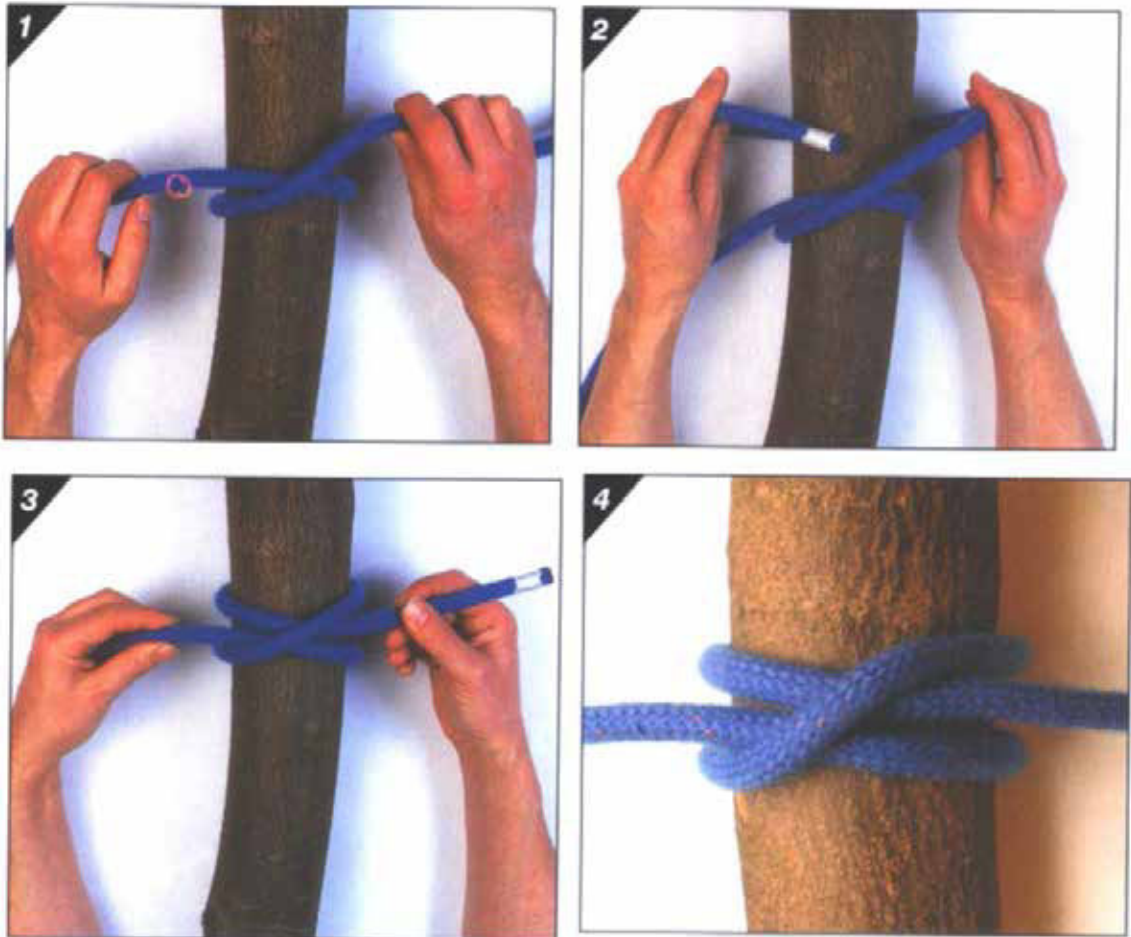

Figure A-3 Steps 1–4

*Note.* From *Pocket Guide to Knots and Splices* (p. 106), by D. Pawson, 2001, London, England: Prospero Books Inc. Copyright 2001 by PRC Publishing Ltd.

1. Make a turn around the pole / tree bringing the working end of the rope over and trapping the standing part of the rope. This makes the first half hitch.
2. Bring the working end round behind the pole / tree, above the first half hitch.
3. Put the working end under the turn just made. This gives the second half hitch and forms the clove hitch.
4. Pull tight to complete the clove hitch.

## KNOT-TYING INSTRUCTIONS

### BOWLINE

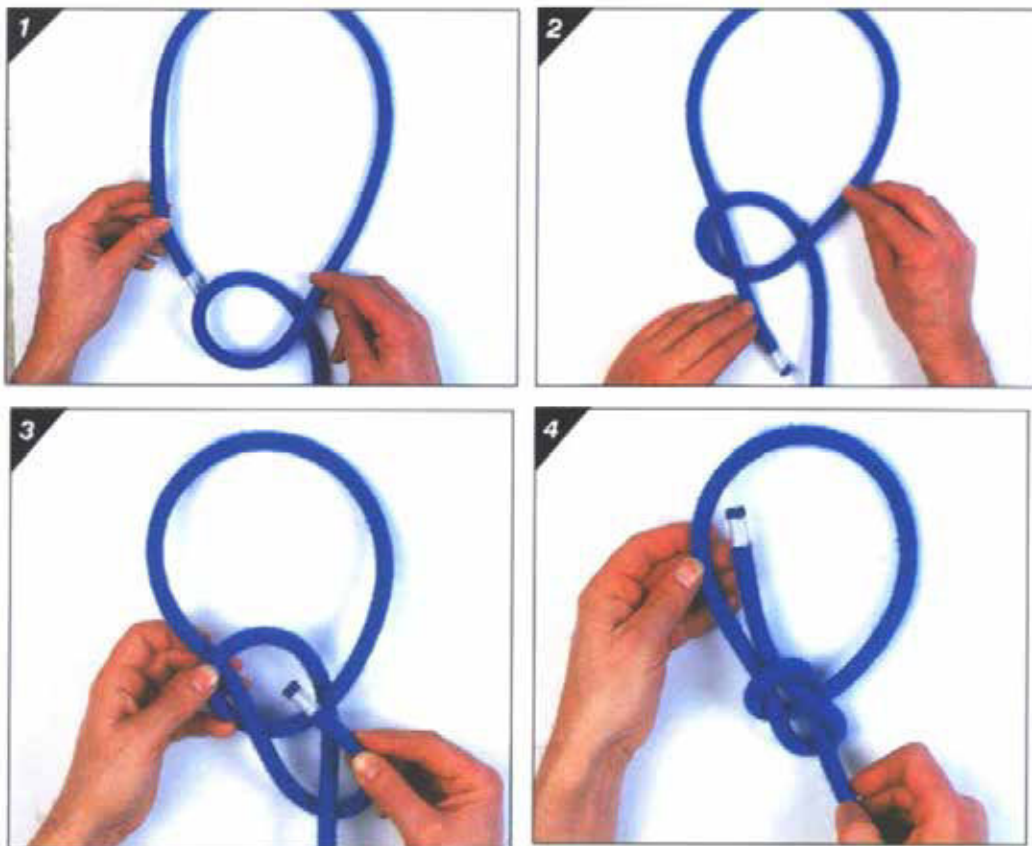

Figure A-4 Steps 1–4

*Note.* From *Pocket Guide to Knots and Splices* (p. 163), by D. Pawson, 2001, London, England: Prospero Books Inc. Copyright 2001 by PRC Publishing Ltd.

1. A short distance back from the working end, make a crossing turn with the working part on top. Go on to form the size of the loop you require.
2. Bring the working end up through the crossing turn. It will go under first, and then lie on top of the other part of the turn.
3. Bring the working end around behind the standing part and down through the crossing turn. A good way to remember this is: “the rabbit comes out of the hole, around the tree and back down the hole again”.
4. Pull tight by holding the working end and pulling on the standing part to complete the bowline.



## LASHING INSTRUCTIONS

### ROUND LASHING

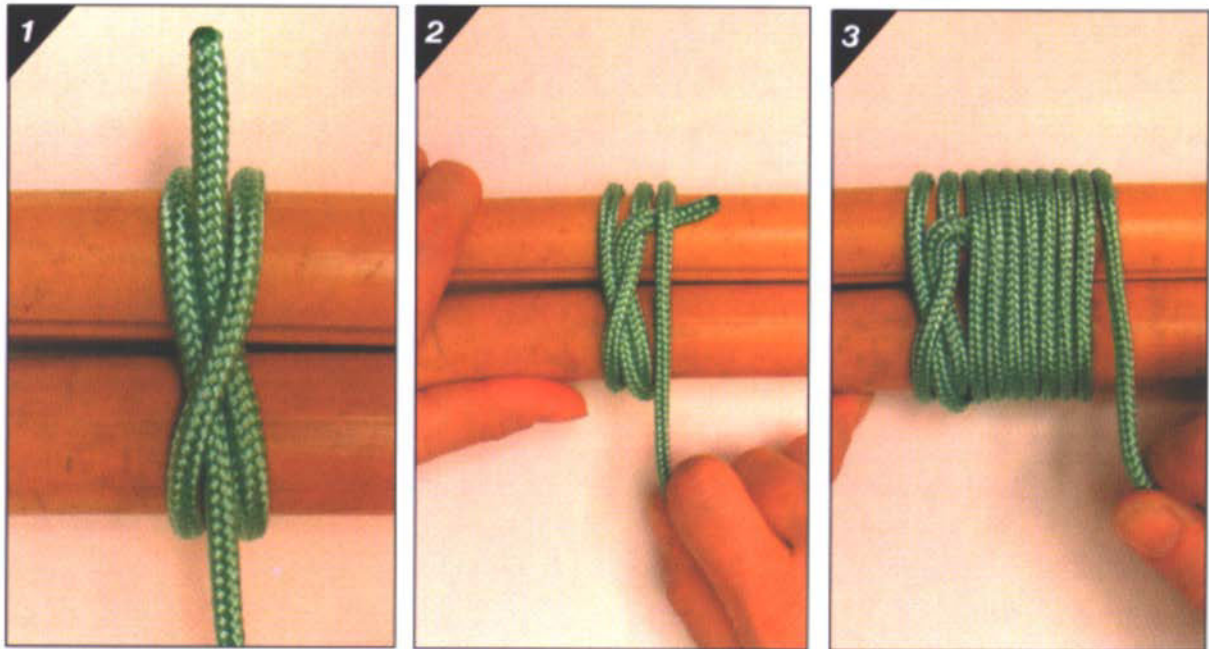

Figure B-1 Steps 1–3

*Note.* From *Pocket Guide to Knots and Splices* (p. 184), by D. Pawson, 2001, London, England: Prospero Books Inc. Copyright 2001 by PRC Publishing Ltd.

1. Start by making a clove hitch around both poles.
2. Wrap around both poles, trapping the end of the clove hitch.
3. Carry on making eight to ten more turns round the pair of poles.

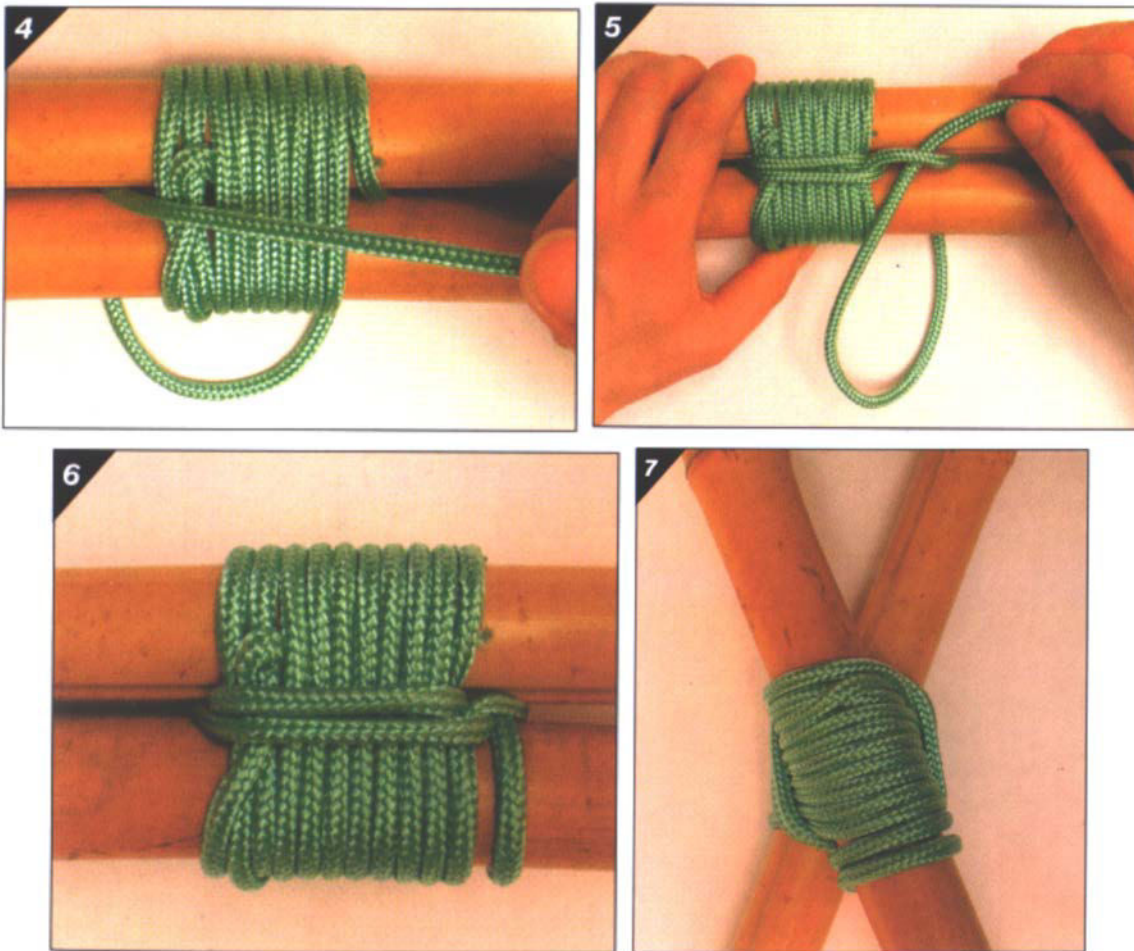

Figure B-2 Steps 4–7

*Note.* From *Pocket Guide to Knots and Splices* (p. 185), by D. Pawson, 2001, London, England: Prospero Books Inc. Copyright 2001 by PRC Publishing Ltd.

4. The lashing could now be finished with a clove hitch around both poles or put in a couple of frapping turns by bringing the end of the rope between the two poles.
5. Finish off with a clove hitch around one of the poles.
6. Pull tight to finish the round lashing with the poles parallel.
7. If being used for an "A" frame then open the poles.



## LASHING INSTRUCTIONS

### SQUARE LASHING

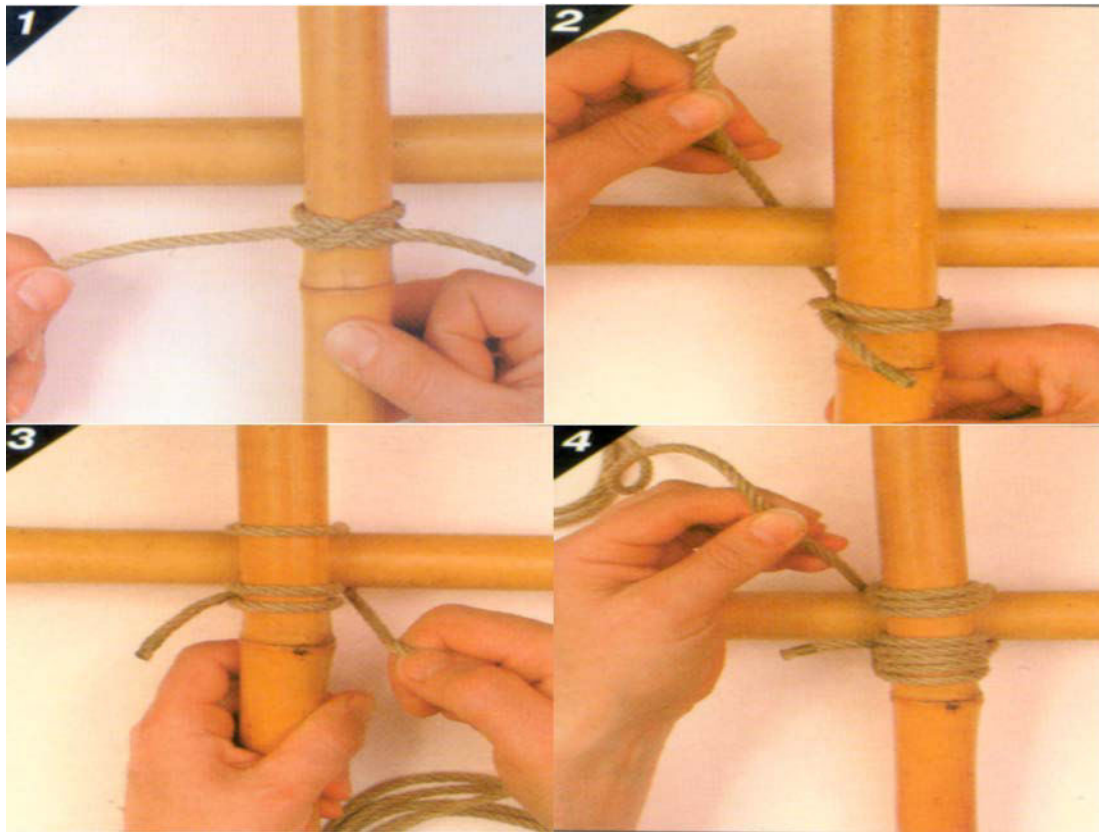

Figure B-3 Steps 1–4

*Note.* From *Pocket Guide to Knots and Splices* (p. 181), by D. Pawson, 2001, London, England: Prospero Books Inc. Copyright 2001 by PRC Publishing Ltd.

1. With the vertical pole on top of the horizontal pole, make a clove hitch on the vertical pole just below the horizontal pole.
2. Bring all the cord around behind the horizontal pole.
3. Bring the cord over the vertical pole and back behind the horizontal pole to the clove hitch. Pull tight.
4. Carry on making two or three more complete turns around the two poles, pulling tight after each turn.

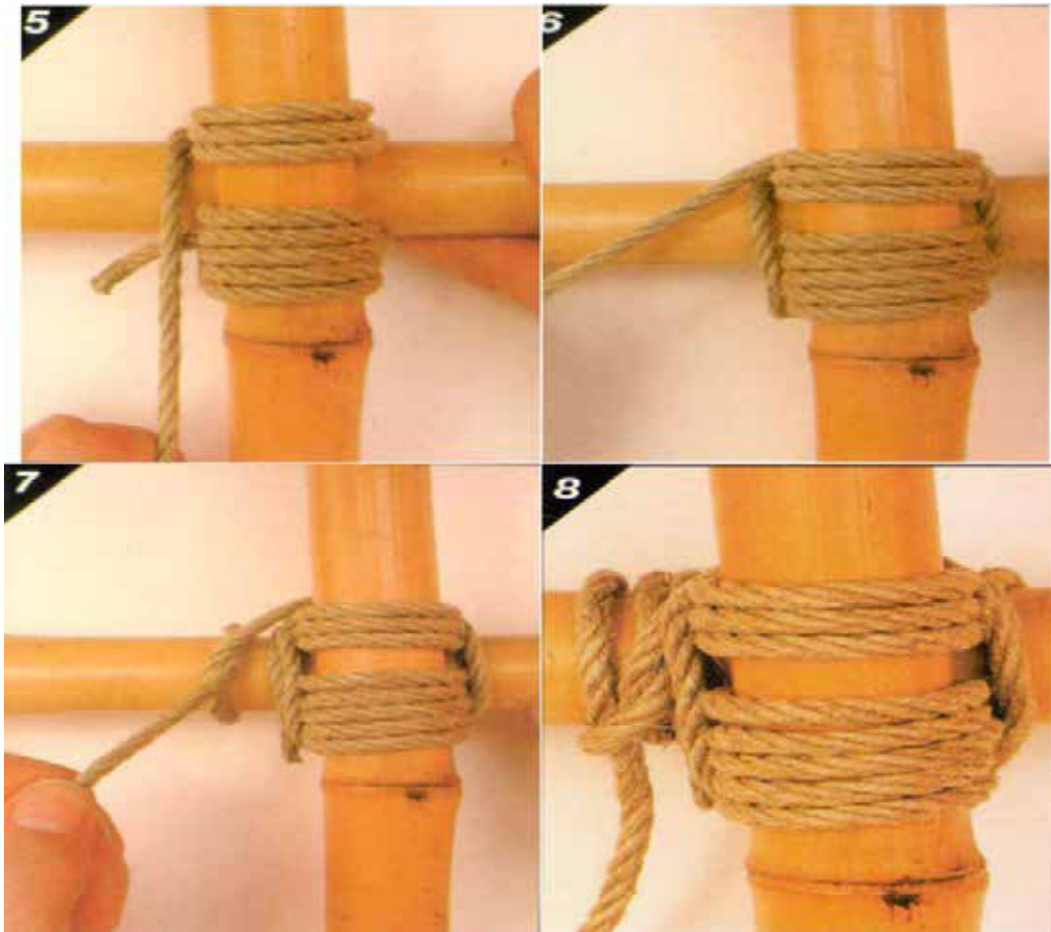

Figure B-4 Steps 5–8

*Note.* From *Pocket Guide to Knots and Splices* (p. 181), by D. Pawson, 2001, London, England: Prospero Books Inc. Copyright 2001 by PRC Publishing Ltd.

5. After passing the clove hitch, bring the cord around the horizontal pole from behind and start to wrap around the junction between the two poles. These are frapping turns—pull them as tight as possible.
6. Make two frapping turns.
7. Finish off with a clove hitch around the horizontal pole.
8. Pull tight to complete the square lashing.

## LASHING INSTRUCTIONS

### FIGURE-OF-EIGHT LASHING

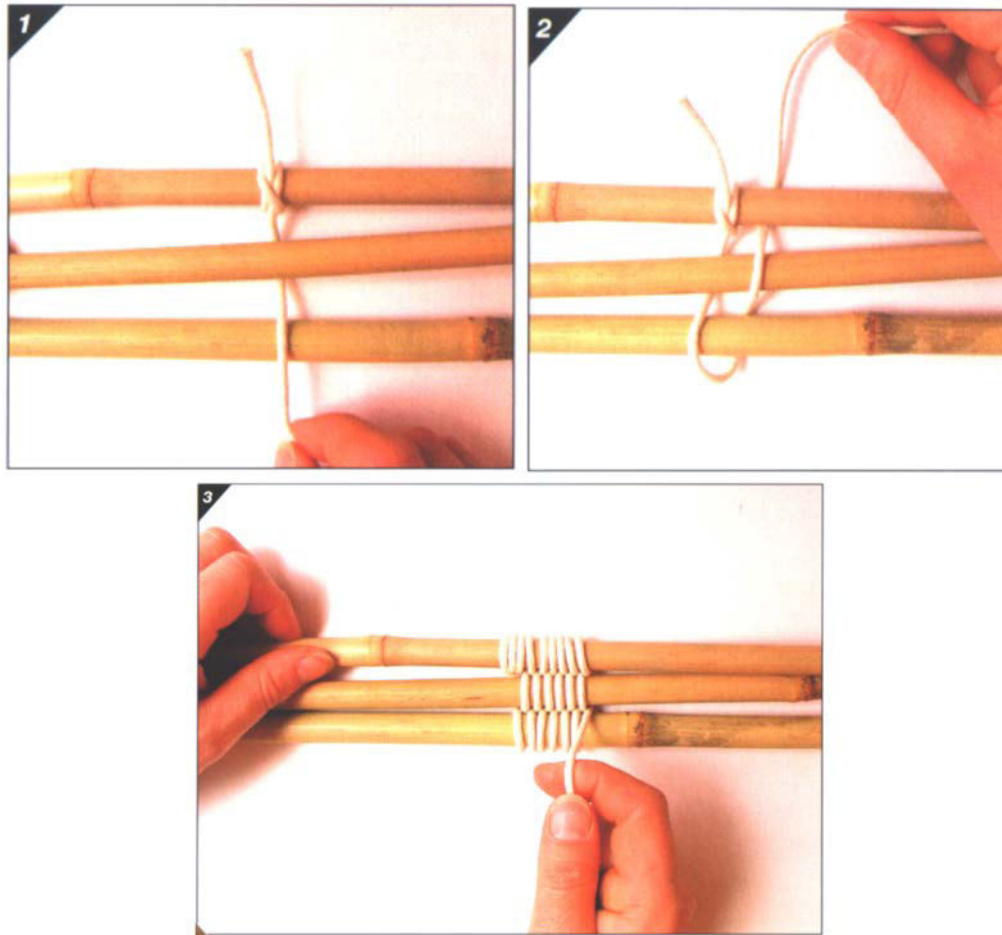

Figure B-5 Steps 1–4

*Note.* From *Pocket Guide to Knots and Splices* (p. 187), by D. Pawson, 2001, London, England: Prospero Books Inc. Copyright 2001 by PRC Publishing Ltd.

1. Start with a clove hitch around one of the poles, and lead the rope under and over the other two poles.
2. Go around the pole furthest away from the start and weave the rope back over and under.
3. Continue to weave the rope in the figure-of-eight manner for seven or eight full passes before bringing the rope up between two of the poles.

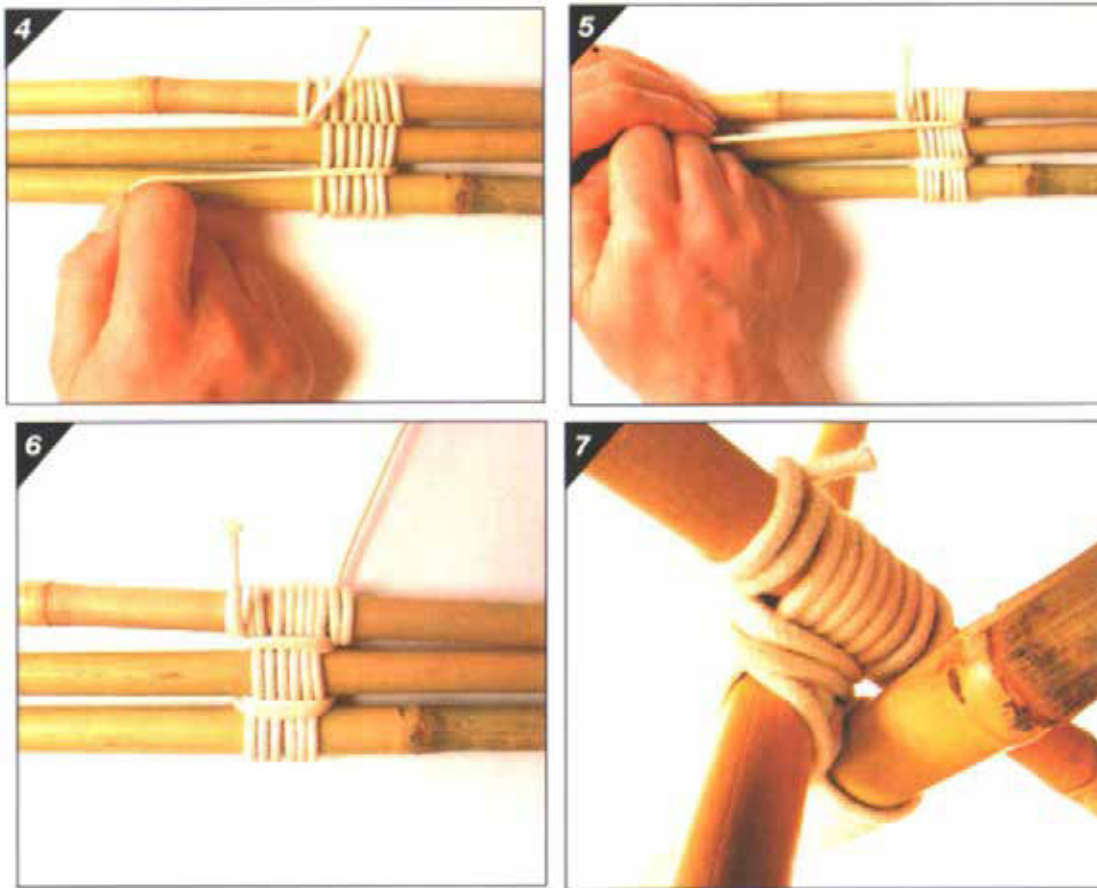

Figure B-6 Steps 4–7

*Note.* From *Pocket Guide to Knots and Splices* (p. 188), by D. Pawson, 2001, London, England: Prospero Books Inc. Copyright 2001 by PRC Publishing Ltd.

4. Pull the rope parallel to the poles and start to put in some frapping turns.
5. After making frapping turns between the first two poles move on to make frapping turns around the other pair of poles.
6. Finish off with a clove hitch around the pole from which you first started.
7. Open to create tripod.



**ROYAL CANADIAN AIR CADETS**  
**PROFICIENCY LEVEL FOUR**  
**INSTRUCTIONAL GUIDE**



**SECTION 4**

**EO M490.04 – NAVIGATE TO A WAYPOINT USING A  
 GLOBAL POSITIONING SYSTEM (GPS) RECEIVER**

---

Total Time:	120 min
-------------	---------

---

**PREPARATION**

---

**PRE-LESSON INSTRUCTIONS**

Resources needed for the delivery of this lesson are listed in the lesson specification located in A-CR-CCP-804/PG-001, *Proficiency Level Four Qualification Standard and Plan*, Chapter 4. Specific uses for said resources are identified throughout the instructional guide within the TP for which they are required.

Review the lesson content and become familiar with the material prior to delivering the lesson.

Photocopy the GPS receiver's Functions Image and the GPS receiver's Function Key Uses pages from the GPS manual for each cadet.

Photocopy the Waypoint Form located at Attachment A and cut it in two.

Mark off five specific waypoints. The waypoints should be at a physical object (eg, tree, fence post, street marker, telephone booth, etc.). Each waypoint should have a small container or plastic bag containing an object or written clue. The waypoint should be marked to indicate it is part of this lesson. The waypoints should be between 200–500 m apart.

Test and ensure the GPS receivers and hand-held radios are functional and have fully-charged batteries.

**PRE-LESSON ASSIGNMENT**

Nil.

**APPROACH**

A demonstration was chosen for TP 1 as it allows the instructor to demonstrate and explain how to navigate to a waypoint using a GPS receiver.

A practical activity was chosen for TP 2 as it allows the instructor to introduce the GPS receiver while providing an opportunity for the cadets to practice navigating to a waypoint using a GPS receiver under supervision.

---

**INTRODUCTION**

---

**REVIEW**

Nil.

**OBJECTIVES**

By the end of this lesson the cadet shall have navigated to a waypoint using a GPS receiver.

**IMPORTANCE**

It is important for cadets to experience navigating with a GPS receiver so that they have basic knowledge of how a GPS receiver works, enabling them to use a GPS in a survival situation. The skills learned in this lesson parallel the civilian sport of geocaching.

**Teaching Point 1**

**Explain and demonstrate turning on the GPS receiver, selecting the waypoint list, selecting a waypoint, and using the GPS receiver to move to a waypoint.**

Time: 30 min

Method: Demonstration



Due to the variety of available GPS receivers, the information in this TP should reflect the model used by the cadets.



Distribute a photocopy of the GPS receiver's Functions Image and GPS receiver's Function Key Uses and explanations to each cadet.

**TURNING ON A GPS RECEIVER, SELECTING THE WAYPOINT LIST AND SELECTING A WAYPOINT**

Follow the GPS manual for instructions on how to turn on, select a waypoint list and select a waypoint.



Demonstrate to the cadets how to turn on the GPS and select a waypoint.

**USING THE GPS TO MOVE TO A WAYPOINT**

Follow the GPS manual for instructions on how to move to a waypoint.



Have the cadets practice using the GPS receiver, to include:

- turning the unit on;
- selecting the waypoint list;
- selecting a waypoint; and
- moving to the waypoint.

**CONFIRMATION OF TEACHING POINT 1**

The cadets' participation in using the GPS receiver will serve as the confirmation of this TP.



---

**Teaching Point 2**

**Have the cadets practice navigating to a waypoint using a GPS receiver.**

Time: 80 min

Method: Practical Activity

---

**ACTIVITY**

**OBJECTIVE**

The objective of this activity is to have the cadets practice navigating to a waypoint using a GPS receiver.

**RESOURCES**

- GPS receiver,
- Waypoint containers,
- Waypoint locations,
- Hand-held radio (one per group),
- Waypoint Form located at Attachment A (one per group), and
- Pen / pencil.

**ACTIVITY LAYOUT**

Prepared waypoints as per pre-lesson instructions.

**ACTIVITY INSTRUCTIONS**

1. Divide the cadets into groups of four.
2. Distribute the equipment to the cadets.
3. Have the cadets perform a radio check.
4. Demonstrate to the cadets how to complete the Waypoint Form. A sample is located at Attachment B.



The waypoints may be indicated on the Waypoint Form as either the actual waypoint or the title of a waypoint that was previously entered into the GPS (eg. Lat / Lon, or Alpha Seven).

5. Have each cadet lead the group to one of the waypoints using the GPS receiver. It is possible that one or more cadets will lead to more than one waypoint.
6. Before moving to the next waypoint, have the cadets indicate the object or written clue on the Waypoint Form.
7. Have the cadets move through the five waypoints.
8. Gather the equipment.
9. Debrief the cadets on the activity.



**SAFETY**

- Each group will have a separate instructor during the navigation activity.
- Ensure cadets observe pedestrian safety during the navigation activity.

---

**CONFIRMATION OF TEACHING POINT 2**

The cadets' participation in the activity will serve as the confirmation of this TP.

---

**END OF LESSON CONFIRMATION**

The cadets' participation in navigating to a waypoint along a predetermined route using a GPS receiver will serve as the confirmation of this lesson.

---

**CONCLUSION**

---

**HOMEWORK / READING / PRACTICE**

Nil.

**METHOD OF EVALUATION**

This EO is assessed IAW A-CR-CCP-804/PG-001, *Proficiency Level Four Standard and Plan*, Chapter 3, Annex B, 490 PC.

**CLOSING STATEMENT**

The GPS receiver is a very powerful navigational tool which, like so many current technologies, continues to appear in other endeavours with a revolutionary effect. If a GPS is available in a survival situation, you can move effectively to safety or rescue.

**INSTRUCTOR NOTES / REMARKS**

Several waypoints should be set up before this lesson.

The waypoints should be indicated on the ground or object by a marker.

The waypoints should be 200 m–500 m apart.

Cadets who are qualified Survival Instructor may assist with this instruction.

---

**REFERENCES**

---

C2-143 ISBN 1-58923-145-7 Featherstone, S. (2004). *Outdoor guide to using your GPS*. Chanhassen, MN: Creative Publishing International, Inc.

THIS PAGE INTENTIONALLY LEFT BLANK

**WAYPOINT FORM**

TEAM				
NO	WAYPOINT	CLUE	START TIME	END TIME
1				
2				
3				
4				
5				

..... Cut Here .....

**WAYPOINT FORM**

TEAM				
NO	WAYPOINT	CLUE	START TIME	END TIME
1				
2				
3				
4				
5				

THIS PAGE INTENTIONALLY LEFT BLANK

**EXAMPLE OF COMPLETED WAYPOINT FORM**

**WAYPOINT FORM**

TEAM				
NO	WAYPOINT	CLUE	START TIME	END TIME
<b>1</b>	60° 40' 30"N 135° 08' 30"W	Purple plastic elephant	1400 hrs	1412 hrs
<b>2</b>	48° 19' 50" N 070° 59' 47" W	Grey plastic army man	1415 hrs	1424 hrs
<b>3</b>	54° 24' 18" N 110° 16' 46" W	The word yellow	1429 hrs	1437 hrs
<b>4</b>	44° 16' 18" N 079° 54' 43" W	Orange peel	1445 hrs	1455 hrs
<b>5</b>	44° 59' 04" N 064° 55' 01" W	Blue plastic airplane	1458 hrs	1505 hrs

THIS PAGE INTENTIONALLY LEFT BLANK



**ROYAL CANADIAN AIR CADETS  
PROFICIENCY LEVEL FOUR  
INSTRUCTIONAL GUIDE**



**SECTION 5**

**EO M490.05 – LIGHT FIRES USING IMPROVISED IGNITION**

---

Total Time:	120 min
-------------	---------

---

**PREPARATION**

---

**PRE-LESSON INSTRUCTIONS**

Resources needed for the delivery of this lesson are listed in the lesson specification located in A-CR-CCP-804/PG-001, *Proficiency Level Four Qualification Standard and Plan*, Chapter 4. Specific uses for said resources are identified throughout the instructional guide within the TP for which they are required.

Review the lesson content and become familiar with the material prior to delivering the lesson.

TPs 4 and 6 should be conducted on a sunny day.

For TPs 3–6, the cadets are only required to light the tinder.

**PRE-LESSON ASSIGNMENT**

Nil.

**APPROACH**

A demonstration was chosen for TPs 1 and 2 to allow the cadets to observe lighting a fire with a bow drill and a fire piston, and to stimulate interest in lighting fires using improvised ignition.

A demonstration and performance was chosen for TPs 3–6 as it allows the instructor to explain and demonstrate lighting fires with improvised ignition and permits the cadets to practice lighting fires under supervision.

---

**INTRODUCTION**

---

**REVIEW**

Nil.

**OBJECTIVES**

By the end of this lesson the cadet shall be expected to light fires using improvised ignition.

**IMPORTANCE**

It is important for cadets to light fires using improvised ignition to demonstrate the basics for achieving the ignition of tinder. This is a fundamental skill that will enable the cadet to be warm and dry in any survival situation. Practicing these skills will enable the cadet to demonstrate these techniques to other cadets at the squadron.

**Teaching Point 1****Explain and demonstrate lighting a fire using a bow drill.**

Time: 15 min

Method: Demonstration

**BOW DRILL**

The bow drill is one of the oldest known methods of starting a fire.

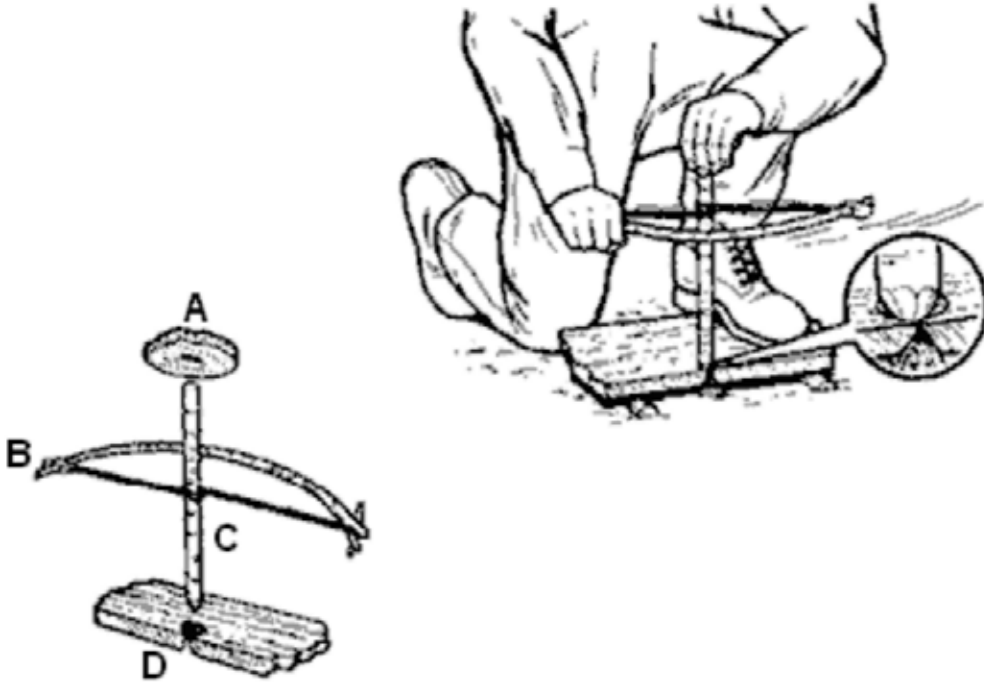

Figure 1 The Bow Drill

*Note.* From *U.S. Army Survival Handbook* (p. 132), by Department of the Army, 2002, Guilford, CT: The Lyons Press.

The parts of a bow drill are:

- A.** The bearing block or handhold,
- B.** The bow,
- C.** The spindle or drill, and
- D.** The hearth or fire board.

The spindle is held at one end by the bearing block and at the other by the hearth. The middle of the bow string is wrapped around the spindle one or more times. Moving the bow back and forth causes the spindle to spin. This spinning movement and pressure on the bearing block causes friction at the spindle hearth contact point.

**The Bearing Block or Handhold**

The bearing block can be made of anything that will protect the hand and apply pressure to the top of the spindle. Hardwood is easiest to procure, but bone, antler and stone work best as they can be easily lubricated, do not create as much friction, and do not burn. An indentation should be cut into the bottom of the block, matching the top of the spindle. The handhold can be lubricated with fat, grease, mud, soap or oil from the hair or face.

**The Bow**

The bow is constructed from a piece of wood and cordage. The bow string should be approximately 6 mm (1/4 inch) diameter cord. The bow should be approximately 60–75 cm (24–30 inches) long and have a curve



that measures 8–10 cm (3–4 inches) high when the ends are placed on a flat surface. The bow should be constructed from green wood or dry hardwood approximately the thickness of the thumb. Notches cut into the ends of the bow will help keep the bow string in place. A clove hitch should be used to fasten the cordage to the ends of the bow. The bow should maintain the proper tension on the bow string, allowing it to spin the spindle between the bearing block and the hearth. When using natural cordage, use less tension on the cord to prevent breakage.

### The Spindle or Drill

The spindle is a piece of hard or softwood, about thumb thickness, usually 15–20 cm (6–8 inches) long. To create a properly shaped hole in the hearth, the spindle should be pointed on the bottom. To reduce friction at the top of the spindle, it should be chamfered (bevelled all around the edge) to a 45-degree angle.

### The Hearth or Fire Board

The hearth is a rectangular piece of softwood, approximately 30 cm (12 inches) long, 6 cm (2 1/2 inches) wide and 1 cm (1/2 inch) thick. An indentation should be carved into the hearth, one spindle thickness in (from the edge), on the long edge of the hearth.

### Using the Bow Drill

The position that a person assumes while operating the bow drill is as follows:

1. Place the right knee on the ground (assuming a right-handed operator) with the hearth located under the arch of the left foot, and the carved indentation to the right of the left foot.
2. Place the left wrist, holding the handhold, in front of the left shin to brace the hand and the handhold.
3. Hold the bow, with the cordage wrapped around the middle of the spindle, in the right hand. Place the spindle between the hearth and the handhold. Friction is achieved by pushing down on the handhold with the left hand and spinning the drill by pulling and pushing the bow with the right hand.

The hearth and spindle must be broken in before a glowing ember can be obtained. The heat of the friction between the hearth and the spindle creates charred dust. This dust will appear light brown at first. Continue spinning the spindle until the dust is dark brown. The spindle and indentation in the hearth now have matching profiles.

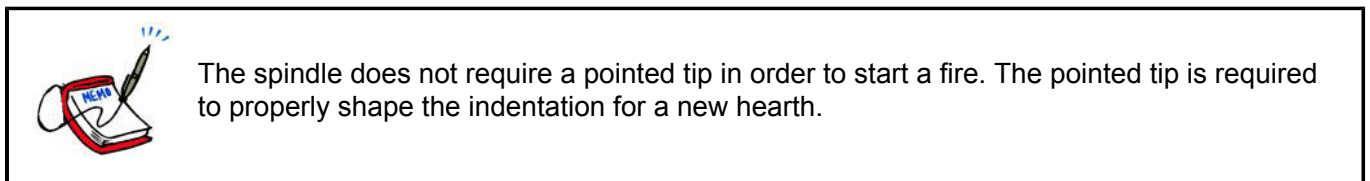

Cut a notch in the edge of the hearth perpendicular to the indentation created by the spindle. It should be wide enough to allow the dust to fall and collect in the notch. Place flat material under the notch to catch the dust and eventually the ember. Continue to spin the spindle with the bow and the dust will turn black and begin to smoke. Carefully watch for a glowing ember on the tinder. Carefully blowing on the ember will ignite the tinder.

---

## CONFIRMATION OF TEACHING POINT 1

### QUESTIONS:

- Q1. What are the four parts of a bow drill?
- Q2. What is the easiest material to find to use as a handhold?
- Q3. What is the usual position for using a bow drill?

**ANTICIPATED ANSWERS:**

A1. The four parts of a bow drill are:

- the bearing block or handhold,
- the bow,
- the spindle or drill, and
- the hearth or fire board.

A2. Hardwood.

A3. The usual position that a person assumes operating the bow drill is as follows:

1. Place the right knee on the ground (assuming a right-handed operator) with the hearth located under the arch of the left foot and the carved indentation to the right of the left foot.
2. Place the left wrist, holding the handhold, in front of the left shin to brace the hand and the handhold.
3. Hold the bow, with the cordage wrapped around the middle of the spindle, in the right hand. Place the spindle between the hearth and the handhold. Friction is achieved by pushing down on the handhold with the left hand and spinning the drill by pulling and pushing the bow with the right hand.

---

**Teaching Point 2**

**Explain and demonstrate lighting a fire using a fire piston.**

Time: 15 min

Method: Demonstration

---

**FIRE PISTON**

The fire piston is an ancient method of starting fires. It is believed to have originated in areas that developed blowguns in East Asia.

The fire piston is a unique method of producing fire. Fire pistons rely on the principle that compressing a volume of air raises its temperature. This is the same principle that is used in diesel engines. If air is compressed quickly enough, it can ignite tinder.

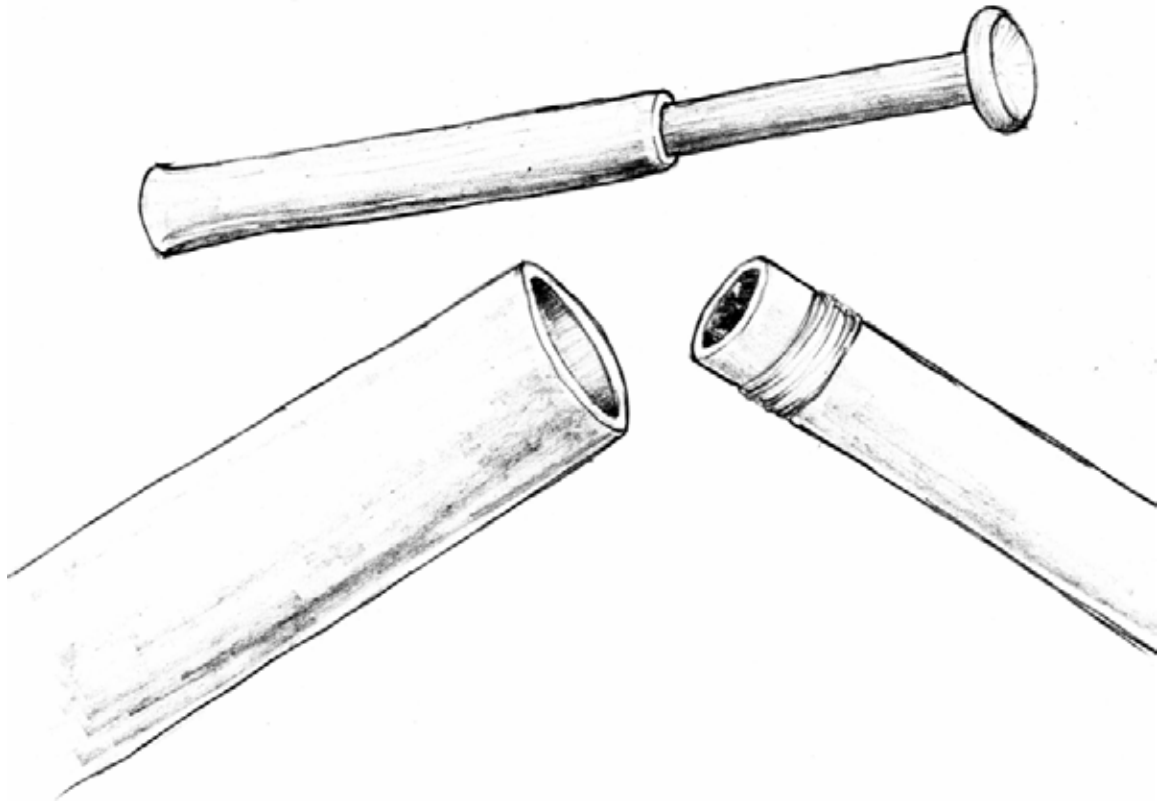

Figure 2 Fire Piston

*Note.* Created by Director Cadets 3, 2009, Ottawa, ON Department of National Defence.

A fire piston consists of a closed end cylinder and a plunger. The plunger should fit into the cylinder with an airtight seal. Tinder is placed into the cylinder (or in a hole on the end of the plunger) and the plunger is inserted a short way into the cylinder. The plunger is quickly forced down into the cylinder, compressing the air and raising its temperature, igniting the tinder and creating an ember. The movement is similar to smacking the plunger into the cylinder. The compressed air in the cylinder pushes the plunger outward. The plunger is quickly removed and the ember carefully removed and placed into a larger bundle of tinder and then blown into flame.

Traditionally, bamboo was used to construct fire pistons but they can be crafted from metal tubing salvaged from an aircraft or vehicle or carefully carved from hardwood.

---

## CONFIRMATION OF TEACHING POINT 2

### QUESTIONS:

- Q1. What principle does the fire piston use?
- Q2. What are the two main parts of a fire piston?
- Q3. From what material can fire pistons be crafted?

**ANTICIPATED ANSWERS:**

- A1. Fire pistons rely on the principle that compressing a volume of air raises its temperature.
- A2. The cylinder and plunger.
- A3. Traditionally, bamboo was used to construct fire pistons but they can be crafted from metal tubing salvaged from an aircraft or vehicle or carefully carved from hardwood.

---

**Teaching Point 3**

**Explain, demonstrate and have the cadets light a fire using a magnesium fire starter.**

Time: 20 min

Method: Demonstration and Performance

---



For this skill lesson, it is recommended that instruction take the following format:

1. Explain and demonstrate the complete skill while cadets observe.
2. Explain and demonstrate each step required to complete the skill. Monitor cadets as they imitate each step.
3. Monitor the cadets' performance as they practice the complete skill.

Note: Assistant instructors may be employed to monitor cadet performance.

Magnesium is a metal, that when powdered or shaved, will ignite from a spark. It burns at a very high temperature, making it an effective way to light a fire.

A magnesium fire starter consists of a piece of magnesium and a striking rod. Shaved off pieces of magnesium can be used with a rock or steel object to strike a spark onto the shavings.



Figure 3 Magnesium Fire Starter

*Note.* Created by Director Cadets 3, 2009, Ottawa, ON, Department of National Defence

The steps to use a magnesium fire starter are:

1. Prepare the area for the fire by assembling tinder and wood for the fire.
2. Place the bottom edge of the magnesium block on a small rock or piece of wood next to the tinder. The small rock or piece of wood will prevent the magnesium block from sinking into soft ground during the shaving process.
3. Using a knife blade, scrape the magnesium, making a small pile approximately the size of a quarter, at the base of the block.



The magnesium shavings are very light in weight. When experiencing high wind conditions, use your body or an object as a wind block and create a small depression where the block is resting on to catch the shavings.

4. Support the edge of the tool on the small rock or piece of wood approximately 25 cm (1 inch) from the pile of magnesium shavings. Using a piece of steel or a sharp rock, strike the sparking side of the magnesium

block. Position the magnesium block so the spray of sparks is directed onto the pile of magnesium shavings. This will ignite the magnesium shavings.



Always move the tinder to the magnesium. The burning magnesium is too hot to handle. Carefully place pieces of tinder on the pile of burning magnesium shavings.

---

### ACTIVITY

Time: 5 min

#### OBJECTIVE

The objective of this activity is to have the cadets light a fire using a magnesium fire starter.

#### RESOURCES

- Magnesium fire starter,
- Knife,
- Tinder, and
- Pails of sand.

#### ACTIVITY LAYOUT

Nil.

#### ACTIVITY INSTRUCTIONS

1. Distribute the magnesium fire starters, knives, and tinder to each cadet.
2. Have each cadet scrape the magnesium block to produce a pile of shavings.
3. Have each cadet ignite the shavings and then add tinder to the burning magnesium.
4. After confirmation that the tinder has been lit, have the cadets extinguish the burning tinder using sand.
5. Gather the equipment.
6. Debrief the cadets on the activity.

#### SAFETY

Magnesium burns at a temperature of approximately 2200 degrees Celsius. The flames from burning magnesium seldom pass 30 cm in height. It will only burn as shavings or dust.

Burning magnesium is hard to extinguish as it can burn in nitrogen and carbon dioxide.

Under no circumstances should water be used to extinguish a magnesium fire.

A carbon dioxide (CO<sub>2</sub>) fire extinguisher will not extinguish a magnesium fire.

Sand can be used to extinguish a magnesium fire.

---

#### CONFIRMATION OF TEACHING POINT 3

The cadets' participation in the activity will serve as the confirmation of this TP.

**Teaching Point 4****Explain, demonstrate and have the cadets light a fire using an aluminium can and a bar of chocolate.**

Time: 20 min

Method: Demonstration and Performance



Dark tinted sunglasses will help alleviate eye strain and allow visual confirmation of the focal point.



For this skill lesson, it is recommended that instruction take the following format:

1. Explain and demonstrate the complete skill while cadets observe.
2. Explain and demonstrate each step required to complete the skill. Monitor cadets as they imitate each step.
3. Monitor the cadets' performance as they practice the complete skill.

Note: Assistant instructors may be employed to monitor cadet performance.

When the Sun's rays are focused, either through a lens or a concave reflector, they can generate enough heat to ignite tinder. The bottom of an aluminum can may have a concave shape suitable for focusing the Sun's rays. Polishing this concave shape with a compound will allow it to focus the Sun's rays. Possible polishing compounds can include:

- toothpaste,
- sink cleaner,
- chocolate, or
- very fine steel wool.

Toothpaste and sink cleaner have an aggressive grit and will polish the concave bottom quickly but will be less reflective. Chocolate has a fine grit and can take up to one hour to polish the concave bottom. The type of chocolate used can affect the time required to polish the bottom. Pure dark chocolate is best. Chocolate with nuts or raisins may take longer to polish the can. White chocolate usually does not have an abrasive quality. If more than one type of polish is available, start the process with the coarsest polishing compound and finish with the finest.



The aluminum particles removed from the can's bottom are considered harmful. They appear as a blackening of the polishing compound. Do not put any substance used in polishing in the mouth. Wash hands before eating. Do not eat the chocolate used to polish the can's bottom.



Figure 4 Polishing the Aluminum Can Bottom

*Note.* From "Fire from a can of coke and a chocolate bar", by W. Muma, 2003, *Wildwood Survival*, Copyright 2003 by W. Muma. Retrieved April 6, 2009, from <http://www.wildwoodsurvival.com/survival/cokecanandchocolatebar/index.html>

### **Polishing the Aluminium Can Base**

Apply some polishing compound to a soft cloth. If using chocolate, the wrapper can be used as the polishing cloth. Polish the bottom of the can in a circular motion until the bottom has a mirror finish. The polishing will remove any evidence of printed information on the can's bottom. Embossed numbers or letters will not affect the can's ability to focus the Sun's rays.





Figure 5 Verifying the Polish

*Note.* From "Fire from a can of coke and a chocolate bar", by W. Muma, 2003, *Wildwood Survival*, Copyright 2003 by W. Muma. Retrieved April 6, 2009, from <http://www.wildwoodsurvival.com/survival/cokecanandchocolatebar/index.html>

The state of polish can be verified by examining the reflection of an object in the centre of the bottom of the can. Look for a clear reflection.

### **Igniting Tinder with the Focused Rays of the Sun**

Several factors must be addressed when using this method. Full sun is required to use the can's polished bottom to ignite the tinder. The tinder must be very dry and sized to allow as much of the sun's rays as possible to enter the concave bottom of the can. The tinder must be centred at the focal point of the sun's rays. The can bottom and the tinder should be held still and close to the face to allow blowing on the tinder. Some types of tinder will smoke but will not ignite unless air is added. This is done by blowing gently on the tinder while the sun's rays are focused on it.



Figure 6 Large Ring of Light

Note. From "Fire from a can of coke and a chocolate bar", by W. Muma, 2003, *Wildwood Survival*, Copyright 2003 by W. Muma. Retrieved April 6, 2009, from <http://www.wildwoodsurvival.com/survival/cokecanandchocolatebar/index.html>



Figure 7 Medium Ring of Light

Note. From "Fire from a can of coke and a chocolate bar", by W. Muma, 2003, *Wildwood Survival*, Copyright 2003 by W. Muma. Retrieved April 6, 2009, from <http://www.wildwoodsurvival.com/survival/cokecanandchocolatebar/index.html>



Figure 8 Focused Spot of Light

*Note.* From "Fire from a can of coke and a chocolate bar", by W. Muma, 2003, *Wildwood Survival*, Copyright 2003 by W. Muma. Retrieved April 6, 2009, from <http://www.wildwoodsurvival.com/survival/cokecanandchocolatebar/index.html>



Figure 9 Using the Aluminum Can and Tinder

*Note.* From "Fire from a can of coke and a chocolate bar", by W. Muma, 2003, *Wildwood Survival*, Copyright 2003 by W. Muma. Retrieved April 6, 2009, from <http://www.wildwoodsurvival.com/survival/cokecanandchocolatebar/index.html>

The focal point of the Sun's rays passing through a convex lens or reflected by a concave reflector is the hottest point. This is where the tinder will ignite. To find the focal point, hold the can in one hand with the bottom pointed directly to the sun. The tinder can be placed on the end of a twig to avoid blocking the Sun's rays from the can's bottom.

To determine the best position for the can, hold the twig with the tinder so that the tinder is approximately three cm from the bottom of the centre of the can. Keep fingertips to the side of the can. The tinder can also be long and thin to avoid blocking sunlight (eg, birch bark, dry grass, slice of shelf mushroom).

Adjust the angle of the can by looking at the ring of light projected onto the underside of the tinder until the oval of sunlight becomes a circle. Sunglasses are recommended for this operation. Bring the tinder closer to or further from the bottom of the can until the circle of sunlight becomes the smallest dot possible. In a few moments, the tinder will start to smoke.

---

## ACTIVITY

Time: 10 min

### OBJECTIVE

The objective of this activity is to have the cadets light tinder using the polished concave bottom of an aluminum can and polishing compound.

### RESOURCES

- Dark tinted sunglasses (one per cadet),
- Aluminum can (one per cadet),
- Chocolate,
- Toothpaste,
- Tinder, and
- Pails of sand.

### ACTIVITY LAYOUT

Nil.

### ACTIVITY INSTRUCTIONS



Polishing the bottom of the aluminum can with chocolate may take up to one hour. Toothpaste is preferred as a polish for this TP. If the cadets cannot finish in the allocated time, polishing of the aluminum can be done on their own time.

1. Distribute an aluminum can, piece of cloth and a dab of toothpaste to each cadet.
2. Have the cadets polish the bottom of the can with the polishing compound.
3. Wearing sunglasses, have the cadets practice establishing the focal point on the tinder.
4. After confirmation that the tinder has been lit, have the cadets extinguish all glowing / lit tinder using sand.
5. Gather the equipment.
6. Debrief the cadets on the activity.

**SAFETY**

A fire extinguisher and pails of sand shall be available at the site.

---

**CONFIRMATION OF TEACHING POINT 4**

The cadets' participation in the activity will serve as the confirmation of this TP.

---

**Teaching Point 5**

**Explain, demonstrate and have the cadets light a fire using a battery, wire and steel wool.**

Time: 20 min

Method: Demonstration and Performance

---

Like magnesium, steel is another metal that can burn when it is shaved or in powder form. Steel wool is made by shaving thin strands of iron off iron wire. It is used in wood and metal manufacturing as a mild abrasive and polish.



Figure 10 Using Batteries and Steel Wool

*Note.* From "Steel wool and a battery", 2003, *Practicalsurvivor.com*, Copyright 2003. Retrieved April 7, 2009, from <http://www.practicalsurvivor.com/node/32>





Figure 11 Battery and Steel Wool Ignition

*Note.* From "Steel wool and a battery", 2003, *Practicalsurvivor.com*, Copyright 2003. Retrieved April 7, 2009, from <http://www.practicalsurvivor.com/node/32>

When an electrical current passes through the strands of steel wool, the electrical resistance of the steel strands causes them to oxidize quickly enough to ignite and burn. The size and shape of the wool allows it to burn. Fine steel wool works best. Adding oxygen to the steel wool by blowing on it will increase the rate of oxidation, causing greater heat. Steel wool will burn when wet. The finer the grade of steel wool, the faster it will burn.

One battery (AA, C and D cell) does not have enough voltage and amperage to ignite the steel wool by itself. Two batteries (AA, C and D cell), a nine volt battery, cell phone or radio battery will ignite the steel wool but this will drain the batteries quickly. This use of batteries should be evaluated carefully as the batteries may be more useful in an object like a GPS, cell phone or radio.

To use steel wool and batteries:

1. Pull the steel wool into a multi-strand bundle long enough to reach both battery terminals.
2. Prepare tinder where the fire will be lit.
3. Place one end of the bundle on one terminal of the batteries.
4. Place the other end of the bundle on the opposite battery terminal.

The bundle of steel wool will ignite immediately and can be added to the tinder.

Steel wool can also be ignited by a spark from flint (hard rock) and steel, the flint of a empty lighter or any other source of spark.

---

## ACTIVITY

Time: 10 min

The objective of this activity is to have the cadets light a fire using a battery and steel wool.

### RESOURCES

- AA batteries (two per cadet),
- Tinder,
- Pails of sand, and
- Steel wool.

### ACTIVITY LAYOUT

Nil.

### ACTIVITY INSTRUCTIONS

1. Distribute the batteries, steel wool and tinder to the cadets.
2. Have the cadets crouch down to the ground and ignite the steel wool with the batteries.
3. Have the cadet place the tinder on the burning steel wool and blow gently on it to ignite the tinder.
4. After confirmation that the tinder is lit, have the cadets extinguish the tinder using sand.
5. Gather the equipment.
6. Debrief the cadets on the activity.

### SAFETY

A fire extinguisher and pails of sand shall be available at the site.

---

### CONFIRMATION OF TEACHING POINT 5

The cadets' participation in the activity will serve as the confirmation of this TP.

---

### Teaching Point 6

**Explain, demonstrate and have the cadets light a fire using a magnifying lens.**

Time: 20 min

Method: Demonstration and Performance

A magnifying lens will accomplish the same objective as the bottom of the aluminum can. It will focus the sun's rays into one point that will ignite tinder. It can be made of glass, plastic, ice or water.

Glass or plastic lenses can be obtained from:

- a magnifying glass,
- binoculars,

- a camera, or
- eyeglasses.

The type of tinder will dictate how much effort will be required to ignite it. Average tinder and a small lens will require additional air to ignite.



Figure 12 Using Binoculars to Ignite Tinder

*Note.* From "Magnifying lens", by W. Muma, 2003, *Wildwood Survival*, Copyright 2003 by W. Muma. Retrieved April 6, 2009, from <http://www.wildwoodsurvival.com/survival/fire/magnifier.html>

Larger and thicker lenses will generate higher temperatures at the focal point but the point may be too far from the lens to be effective. Most eyeglasses will prove difficult to use lighting fires as they do not have the magnification necessary to ignite tinder. Experimentation is necessary to find the focal point of a lens or set of lenses. Before disassembling an object containing lenses, evaluate its worth during the survival situation.



## Fire From Ice



Figure 13 Rough Carved Sphere of Ice

*Note.* From "Fire from ice", by W. Muma, 2003, *Wildwood Survival*, Copyright 2003 by W. Muma. Retrieved April 6, 2009, from <http://www.wildwoodsurvival.com/survival/fire/ice/rb/rbfirefromice4b.html>



Figure 14 Polishing a Sphere of Ice

*Note.* From "Fire from ice", by W. Muma, 2003, *Wildwood Survival*, Copyright 2003 by W. Muma. Retrieved April 6, 2009, from <http://www.wildwoodsurvival.com/survival/fire/ice/rb/rbfirefromice4b.html>



Figure 15 Using a Piece of Tubing to Shape an Ice Sphere

*Note.* From "Fire from ice", by W. Muma, 2003, *Wildwood Survival*, Copyright 2003 by W. Muma. Retrieved April 6, 2009, from <http://www.wildwoodsurvival.com/survival/fire/ice/rb/rbfirefromice4b.html>





Figure 16 Igniting Tinder with an Ice Sphere

*Note.* From "Fire from ice", by W. Muma, 2003, *Wildwood Survival*, Copyright 2003 by W. Muma. Retrieved April 6, 2009, from <http://www.wildwoodsurvival.com/survival/fire/ice/rb/rbfirefromice4b.html>

Spherical ice lenses can be made in cold climates. A sphere of ice used as a lens will give a usable focal point that can be used to ignite tinder. Ice from a lake or shore of a river that is free of air bubbles and crystal clear is necessary for this method of fire lighting. The sphere should be larger than 4 cm (1 1/2 inches) to be effective.

To make a spherical lens of ice:

1. Start by cutting the rough shape from a larger block of ice.
2. Once the spherical shape has been established, turn the sphere in bare hands to smooth and polish the surface. If a metal tube is available (eg. aircraft exhaust or spar tubing) spinning the sphere on the end of the tube will shave it almost perfectly round. The tubing must be slightly smaller in diameter than the ice sphere.
3. The sphere can be held by wrapping a strip of cloth or bootlace around its circumference and twisting it tight.

### Fire From Water



Figure 17 Igniting Tinder with Plastic Wrap and Water

*Note.* From "Fire from ice", by W. Muma, 2003, *Wildwood Survival*, Copyright 2003 by W. Muma.  
Retrieved April 6, 2009, from <http://www.wildwoodsurvival.com/survival/fire/ice/rb/rbfirefromice4b.html>

A clear piece of plastic wrap, balloon or condom can also be used if partially filled with water. The object is to make a perfect sphere by twisting the open end tight so the plastic takes a spherical shape. The Sun's rays can then be focused on the tinder.

1. Place some water in the plastic. The sphere should be larger than 4 cm (1 1/2 inches) to be effective.
2. Twist the opening tightly to form a sphere.

3. Hold the sphere between the tinder and the sun.
4. Locate the focal point and ignite the tinder.



Figure 18 Igniting Tinder with a Broken Light Bulb and Water

*Note.* From "Fire from ice", by W. Muma, 2003, *Wildwood Survival*, Copyright 2003 by W. Muma.  
Retrieved April 6, 2009, from <http://www.wildwoodsurvival.com/survival/fire/ice/rb/rbfirefromice4b.html>

A piece of broken light bulb, wine glass or any other round clear object holding some water can also be used to focus the Sun's rays.

---

### ACTIVITY

Time: 10 min

### OBJECTIVE

The objective of this activity is to have the cadets ignite tinder using a magnifying lens.

**RESOURCES**

- Magnifying lens,
- Clear plastic bag,
- Water,
- Tinder, and
- Pails of sand.

**ACTIVITY LAYOUT**

Nil.

**ACTIVITY INSTRUCTIONS**

1. Have the cadet select a method of ignition from:
  - a. magnifying lens, or
  - b. clear plastic bag.
2. Distribute lens or clear plastic bag and water and tinder to the cadets.
3. Have the cadets ignite the tinder with the selected lens.
4. After confirmation that the tinder is lit, extinguish the tinder using sand.
5. Gather the equipment.
6. Debrief the cadets on the activity.

**SAFETY**

A fire extinguisher and pails of sand shall be available at the site.

---

**CONFIRMATION OF TEACHING POINT 6**

The cadets' participation in the activity will serve as the confirmation of this TP.

---

**END OF LESSON CONFIRMATION**

The cadets' participation in the activities will serve as the confirmation of this lesson.

---

**CONCLUSION**

---

**HOMEWORK / READING / PRACTICE**

Nil.

**METHOD OF EVALUATION**

This EO is assessed IAW A-CR-CCP-804/PG-001, *Proficiency Level Four Standard and Plan*, Chapter 3, Annex B, 490 PC.

## **CLOSING STATEMENT**

There are many methods for igniting tinder in a survival situation. The ones demonstrated in this lesson should be practiced often. The heat and warmth of a fire can be a necessity in a survival situation.

## **INSTRUCTOR NOTES / REMARKS**

Petroleum products such as gasoline should be handled with care due to its combustible properties. Avoid skin contact. Refer to Material Safety Data Sheet (MSDS).

Cadets who are qualified Survival Instructor may assist with this instruction.

---

## **REFERENCES**

---

C3-002 ISBN 0-00-653140-7 Wiseman, J. (1999). *The SAS survival handbook*. Hammersmith, London: HarperCollins Publishers.

C3-003 ISBN 1-896713-00-9 Tawrell, P. (1996). *Camping and wilderness survival: The ultimate outdoors book*. Green Valley, ON: Author.

C3-314 Wildwood Survival. (2009). *Fire from a can of coke and a chocolate bar*. Retrieved February 9, 2009, from <http://www.wildwoodsurvival.com/survival/fire/cokeandchocolatebar/index.html>

C3-315 Primitive Ways. (1996). *The fire piston: Ancient firemaking machine*. Retrieved February 9, 2009, from [http://www.primitiveways.com/fire\\_piston.html](http://www.primitiveways.com/fire_piston.html)





**ROYAL CANADIAN AIR CADETS**  
**PROFICIENCY LEVEL FOUR**  
**INSTRUCTIONAL GUIDE**



**SECTION 6**

**EO C490.01 – DESCRIBE CLIMATIC AND SEASONAL CONCERNS**

---

Total Time: 30 min

---

**PREPARATION**

---

**PRE-LESSON INSTRUCTIONS**

Resources needed for the delivery of this lesson are listed in the lesson specification located in A-CR-CCP-804/PG-001, *Proficiency Level Four Qualification Standard and Plan*, Chapter 4. Specific uses for said resources are identified throughout the instructional guide within the TP for which they are required.

Review the lesson content and become familiar with the material prior to delivering the lesson.

**PRE-LESSON ASSIGNMENT**

Nil.

**APPROACH**

An interactive lecture was chosen for TP 1 to give an overview of climate concerns.

A group discussion was chosen for TP 2 as it allows the cadets to interact with their peers and share knowledge, experiences, opinions, and feelings about seasonal concerns associated with spring, summer, autumn, and winter weather. This helps develop rapport by allowing the instructor to evaluate the cadets' responses in a non-threatening way while helping them refine their ideas. A group discussion also helps the cadets improve their listening skills and develop as members of a team.

---

**INTRODUCTION**

---

**REVIEW**

Nil.

**OBJECTIVES**

By the end of this lesson the cadet shall have described climatic and seasonal factors that affect survival situations.

**IMPORTANCE**

It is important for cadets to describe seasonal concerns, so they can apply the knowledge in a survival situation.

**Teaching Point 1****Describe climate associated with regions and climate change.**

Time: 15 min

Method: Interactive Lecture

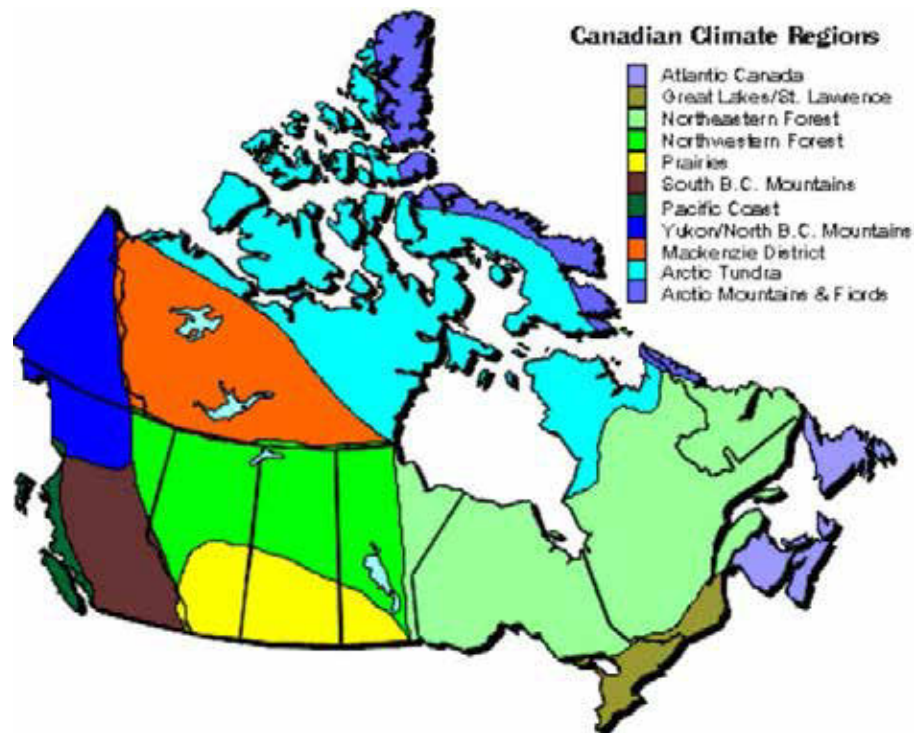

Figure 1 Climate Map

*Note.* From *Canadian Regional Climates*, 2002, by Environment Canada. Retrieved April 17, 2009, from [http://www.msc-smc.ec.gc.ca/ccrm/bulletin/figclimate\\_e.html](http://www.msc-smc.ec.gc.ca/ccrm/bulletin/figclimate_e.html)

It is important to understand each regional climate zone. If an individual is lost or in a survival situation, it is good to know the climate of the region they are surviving in. Canada has 11 regional climates (as illustrated in Figure 1).

**CANADIAN REGIONAL CLIMATE****The West Coast**

British Columbia's coast has the most temperate climate in Canada. It rarely snows in the low-lying areas of the coastal range and the Rocky Mountains block the Pacific air from the Prairies. The valleys between the mountain ranges experience hot summers, almost completely precipitation free.

**The Prairies**

The Prairies extend east of the Rocky Mountains to the Great Lakes. The Prairies has predominant climate, with the cold winters and humid, hot summers.

**The Great Lakes–St. Lawrence**

More than half of the population of Canada lives here. The winters have a lot of snowfall and wind and the summers are humid and longer than anywhere else in Canada.

## **Atlantic Canada**

It has one of the most rugged and variable climates in Canada. In the winter, temperatures can vary as the arctic air is replaced by maritime air from passing storm systems. The snowfall is heavy and fog is often present in the spring and at the beginning of summer. The warmest time of the year is in July, as temperatures average 16–18 degrees Celsius.

## **The North**

The North is mostly covered in snow during the year. The summer lasts for two months and the temperatures rise above freezing for only a few weeks of the year. The temperatures are so cold that the ground is frozen all year long.

## **CLIMATE CHANGE**

### **Environmental Impact**

Canada's climate has increased by 1.3 degrees Celsius since 1948, with the Arctic experiencing the greatest changes of all regions. The warming in the Arctic has led to a decrease in snow cover and sea ice, a degradation of permafrost, and a retreat of glaciers and ice caps. To the south of the Arctic, the winter snow is melting earlier and glaciers are disappearing.

The water levels of the Great Lakes are dropping and sea levels are rising. The temperature increase is causing a longer growing season for plant vegetation.

The climate change is causing increases in related hazards, such as heat waves, droughts, floods, forest fires, storm surges, and coastal erosion. These hazards are not only costly (damage to property and infrastructure) but can be life threatening if climate change increases significantly.

A warming climate in Canada impacts water quantity and quality across the country. Frequent downpours in the Great Lakes could lead to localized flooding and overwhelm current sewage treatment facilities with increases in sewage and stormwater runoff.

The Prairies may see a decline in water levels on ponds, lakes and dugouts, leading to changes in water chemistry, which means less water for crop irrigation.

### **Health Impact**

The health and well-being of Canadians could be affected by the climate change. Some of the health impacts are related to:

- an increasing number of smog and extreme heat events,
- the spread of infectious diseases from insects migrating northward, and
- a decline in the quality and the quantity of drinking water in some areas because of drought.

The health impact varies from one location to another and changes over time, as temperatures and other climatic conditions continue to change.

---

## CONFIRMATION OF TEACHING POINT 1

### QUESTIONS:

- Q1. How many regional climate zones are there in Canada?
- Q2. What are the health impacts related to the climate change in Canada?
- Q3. How does a changing climate impact health?

### ANTICIPATED ANSWERS:

- A1. There are 11 regional climate zones in Canada.
- A2. The health impacts related to climate change in Canada are:
- an increasing number of smog and extreme heat events,
  - the spread of infectious diseases from insect migrating northward, and
  - a decline in the quality and the quantity of drinking water in some areas because of drought.
- A3. The health impact changes from one location to another and over time, as temperatures and other climatic conditions continue to change.

---

### Teaching Point 2

**Conduct a group discussion on seasonal concerns in a survival situation.**

Time: 10 min

Method: Group Discussion

---

## BACKGROUND KNOWLEDGE

---



The point of the group discussion is to draw the following information from the group using the tips for answering / facilitating discussion and the suggested questions provided.

There are four seasons in Canada: spring, summer, autumn and winter.

The following are typical features of seasons in the southern part of Canada:

### Spring

The season starts in March and ends in May. During this period, the snow begins to melt. It is known to be the rainy season in most parts of Canada. The days become warmer, but the nights are still cool. Vegetation starts growing; however, trees remain bare until April or May.

### Summer

The season starts in June and ends in August, though in some parts of Canada the season can last until mid-September. The temperatures in summer may reach 30 degrees Celsius or higher. The season is known to be typically hot and dry with occasional rainstorms / thunderstorms. Humidity is a factor around the Great Lakes region. This is the season of mosquitoes and blackflies.

## Autumn

The season starts in September and ends in November with days becoming shorter. As the days become shorter, temperatures start to fall, and during the night, frost starts to appear. The vegetation starts to die off and leaves start to change colour. During this season, weather is unpredictable with rain and the first signs of snow usually appear in November.

## Winter

The season starts in December and ends in February, sometimes later in some regions of Canada. This season is known for snow and ice. Snow can start as early as October and continue to late March. The temperatures are below zero degrees Celsius from December to mid-March, especially at night. The wind is a factor as well and wind chill can make it feel even colder. The only parts of Canada where temperatures appear to be milder are on the East and West Coasts, where there is more precipitation.

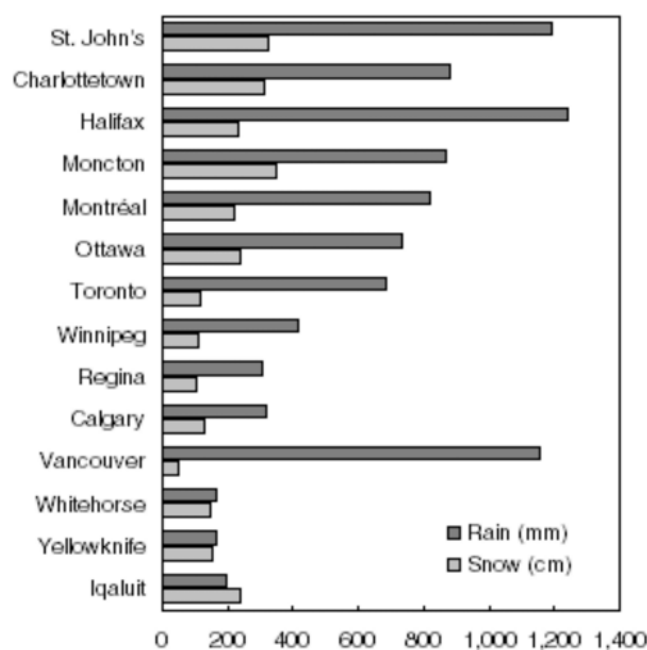

Figure 2 Annual Average Precipitation (1971 to 2000)

Note. From *Canadian Climate Normals*, by Environment Canada (2004). Retrieved April 22, 2009, from [http://www.climate.weatheroffice.ec.gc.ca/climate\\_normals/index\\_e.html](http://www.climate.weatheroffice.ec.gc.ca/climate_normals/index_e.html)

---

## GROUP DISCUSSION

---



### TIPS FOR ANSWERING / FACILITATING DISCUSSION:

- Establish ground rules for discussion, eg, everyone should listen respectfully; don't interrupt; only one person speaks at a time; no one's ideas should be made fun of; you can disagree with ideas but not with the person; try to understand others as much as you hope they understand you; etc.
- Sit the group in a circle, making sure all cadets can be seen by everyone else.
- Ask questions that will provoke thought; in other words avoid questions with yes or no answers.
- Manage time by ensuring the cadets stay on topic.
- Listen and respond in a way that indicates you have heard and understood the cadet. This can be done by paraphrasing their ideas.
- Give the cadets time to respond to your questions.
- Ensure every cadet has an opportunity to participate. One option is to go around the group and have each cadet answer the question with a short answer. Cadets must also have the option to pass if they wish.
- Additional questions should be prepared ahead of time.

### SUGGESTED QUESTIONS:

- Q1. How do the seasonal concerns in the spring affect an individual in a survival situation?
- Q2. How do the seasonal concerns in the summer affect an individual in a survival situation?
- Q3. How do the seasonal concerns in autumn affect an individual in a survival situation?
- Q4. How do the seasonal concerns in the winter affect an individual in a survival situation?



Other questions and answers will develop throughout the group discussion. The group discussion should not be limited to only those suggested.



Reinforce those answers given and comments made during the group discussion, ensuring the teaching point has been covered.

---

### CONFIRMATION OF TEACHING POINT 2

The cadets' participation in the group discussion will serve as the confirmation of this TP.

---

**END OF LESSON CONFIRMATION**

The cadets' participation in the group discussion will serve as the confirmation of this lesson.

---

**CONCLUSION**

---

**HOMEWORK / READING / PRACTICE**

Nil.

**METHOD OF EVALUATION**

Nil.

**CLOSING STATEMENT**

It is important to describe climatic and seasonal concerns so you can apply the knowledge when in a survival situation.

**INSTRUCTOR NOTES / REMARKS**

Cadets who are qualified Survival Instructor may assist with this instruction.

---

**REFERENCES**

---

C3-341 Environment Canada.(2009). *Environmental impacts*. Retrieved April 16, 2009, from <http://www.ec.gc.ca/cc/default.asp?lang=En&n=4630D154-1>

C3-342 Environment Canada. (2009). *Health impacts*. Retrieved April 16, 2009, from <http://www.ec.gc.ca/cc/default.asp?lang=En&n=0B072979-1>

C3-343 O Canada. (2009). *Canadian regional climate*. Retrieved April 16, 2009, from <http://www.ocanada.ca/climate/regional.php>

C3-344 Government of Canada. (2008). *Four seasons*. Retrieved April 22, 2009, from <http://www.goingtocanada.gc.ca/CIC/display-afficher.do?id=000000000039&lang=eng>

THIS PAGE INTENTIONALLY LEFT BLANK





**ROYAL CANADIAN AIR CADETS  
PROFICIENCY LEVEL FOUR  
INSTRUCTIONAL GUIDE**



**SECTION 7**

**EO C490.02 – IMPROVISE TOOLS FOR USE IN A SURVIVAL SITUATION**

---

Total Time:	60 min
-------------	--------

---

**PREPARATION**

---

**PRE-LESSON INSTRUCTIONS**

Resources needed for the delivery of this lesson are listed in the lesson specification located in A-CR-CCP-804/PG-001, *Proficiency Level Four Qualification Standard and Plan*, Chapter 4. Specific uses for said resources are identified throughout the instructional guide within the TP for which they are required.

Review the lesson content and become familiar with the material prior to delivering the lesson.

The following examples of improvised tools should be constructed before this lesson:

- a knife,
- a needle,
- a compass, and
- a hammer.

**PRE-LESSON ASSIGNMENT**

Nil.

**APPROACH**

A group discussion was chosen for TP 1 to allow the cadets to interact with their peers and share knowledge and experiences about the potential of the materials at hand during a survival situation.

A demonstration and performance was chosen for TPs 2 and 3 as it allows the instructor to explain and demonstrate the skill of improvising tools while providing an opportunity for the cadets to practice the skill under supervision.

A demonstration was chosen for TP 4 as it allows the cadets to observe how to construct a hammer.

---

**INTRODUCTION**

---

**REVIEW**

Nil.

**OBJECTIVES**

By the end of this lesson the cadet shall be expected to improvise tools for use in a survival situation.

**IMPORTANCE**

It is important for cadets to improvise tools for use in a survival situation as this skill enables the cadet to adapt to most survival situations. These skills give the survivor purpose and help build morale and spirit.

---

**Teaching Point 1****Discuss the potential of the materials at hand for use in a survival situation.**

Time: 10 min

Method: Group Discussion

---

---

**BACKGROUND KNOWLEDGE**

---



The point of the group discussion is to draw the following information from the group using the tips for answering / facilitating discussion and the suggested questions provided.

A survival situation demands improvisation depending on what tools are available. Even simple tools can have multiple uses. If tools are not available, the surrounding area should be surveyed for possibilities.

Safety is paramount when using any tool or item as a tool. Injuries incurred during a survival situation deplete precious resources and energy and can be demoralizing to the survivor or survivors.

Using what is available should be one of the first things considered for all survival situations.

Usable items may be procured from the environment, vehicles, and buildings.

Vehicles, including cars, bicycles, trucks, heavy machinery, boats, snowmobiles and motorcycles offer some of the same items found on aircraft. Vehicles and buildings may be used as shelter.

Some suggested items that can be used from vehicles are:

- wires,
- mirrors,
- hubcaps,
- control cables,
- leatherette seat covers, and
- antennae.

Some suggested items that can be used from buildings are:

- wires,
- wood,
- glass,
- plastic, and
- various metal and plastic pipes and tubing.

Primitive man has survived in almost all environments on the planet. He has made use of the materials available.

Some suggested items that can be used from the surrounding environment are:

- trees,
- grasses and plants,
- stones,
- dirt,
- sand, and
- animal parts, to include:
  - fat,
  - skin,
  - organs,
  - bones, and
  - sinew.

---

### GROUP DISCUSSION

---



#### **TIPS FOR ANSWERING / FACILITATING DISCUSSION:**

- Establish ground rules for discussion, eg, everyone should listen respectfully; don't interrupt; only one person speaks at a time; no one's ideas should be made fun of; you can disagree with ideas but not with the person; try to understand others as much as you hope they understand you; etc.
- Sit the group in a circle, making sure all cadets can be seen by everyone else.
- Ask questions that will provoke thought; in other words avoid questions with yes or no answers.
- Manage time by ensuring the cadets stay on topic.
- Listen and respond in a way that indicates you have heard and understood the cadet. This can be done by paraphrasing their ideas.
- Give the cadets time to respond to your questions.
- Ensure every cadet has an opportunity to participate. One option is to go around the group and have each cadet answer the question with a short answer. Cadets must also have the option to pass if they wish.
- Additional questions should be prepared ahead of time.

#### **SUGGESTED QUESTIONS:**

- Q1. Why is safety important when using tools in a survival situation?
- Q2. What are some items that can be taken from vehicles?

Q3. What are some items that can be taken from buildings?

Q4. What are some items that can be taken from the surrounding environment?



Other questions and answers will develop throughout the group discussion. The group discussion should not be limited to only those suggested.



Reinforce those answers given and comments made during the group discussion, ensuring the teaching point has been covered.

---

### CONFIRMATION OF TEACHING POINT 1

The cadets' participation in the group discussion will serve as the confirmation of this TP.

---

#### Teaching Point 2

**Explain, demonstrate and have the cadets construct a cutting or piercing tool.**

Time: 15 min

Method: Demonstration and Performance



For this TP, it is recommended that instruction take the following format:

1. Explain and demonstrate the complete skill while cadets observe.
2. Explain and demonstrate each step required to complete the skill. Monitor cadets as they imitate each step.
3. Monitor the cadets' performance as they practice the complete skill.

Note: Assistant instructors may be employed to monitor the cadets' performance.

Cutting and piercing tools can make everyday life in a survival situation easier. They are used to prepare food, assemble shelter and create other tools.

Most purchased cutting and piercing tools are made of stainless or tool steel. Even if these materials are available, they are difficult to work without a forge, machine shop or special metal working tools. Therefore, softer materials like aluminum, bone or plastic should be considered.

A safety razor contains one or more thin blades. These are removed by disassembling the razor's head. Although small and thin, these blades are extremely sharp. The opposite edge should be covered with tape or mounted in wood.

Stone may be shaped into cutting tools, but the technique, called flint knapping, is difficult to master. The sharp edge of broken stones may be used as a cutting tool. Smashing two stones together may leave sharp fragments that will serve as a cutting tool. Use caution when breaking stones as sharp fragments will fly off the broken stone, potentially causing injury.

Broken glass can be used but is brittle and difficult to use without inflicting wounds on the user. A piece of broken glass has cutting edges on all sides. Covering the opposite edge of the tool with thick tape or in a grooved stick may prevent injury. Glass is very fragile and will not endure hard use as a cutting tool.

Bone, metal or plastic can be used to fashion cutting or piercing tools but the edge or point will not remain sharp. Adding small teeth to the edge of a cutting tool will help during cutting. Aluminum and other soft metal cutting edges can be formed by pounding the edge between two stones. The edge of a cutting tool and size of the blade should not exceed 10 cm. Longer edges become unwieldy in use.

Bone can be fashioned into a sewing needle. Strike the bone with a stone to create splinters. These splinters can be smoothed and shaped by rubbing on a stone. To pierce a hole for the eye of the needle, a sharp chip of stone can be set and bound in a split stick and spun between the hands to create a drill.

Handle material can be wood, with wire, strong material (seat cover, or leather) or cord wrapping. The handle should be comfortable in the hand and securely fastened to the blade.

When not being used, a protective cover can be fashioned from strong material to protect the knife and user.

---

## CONFIRMATION OF TEACHING POINT 2

The cadets' construction of a cutting / piercing tool will serve as the confirmation of this TP.

---

### Teaching Point 3

**Explain, demonstrate and have the cadets construct a compass.**

Time: 15 min

Method: Demonstration and Performance



For this skill lesson, it is recommended that instruction take the following format:

1. Explain and demonstrate the complete skill while cadets observe.
2. Explain and demonstrate each step required to complete the skill. Monitor cadets as they imitate each step.
3. Monitor the cadets' performance as they practice the complete skill.

Note: Assistant instructors may be employed to monitor the cadets' performance.

A compass needle points north because the needle is magnetized and becomes aligned by the earth's magnetic field. An improvised compass can be created from a small strip of ferrous metal and a container of water.

To magnetize the ferrous metal several methods may be employed. A sewing needle is an excellent piece of ferrous metal to magnetize as it is light in weight and easily magnetized.

#### Method 1:

Stroke a piece of silk fabric repeatedly in one direction (from the eye end to the point).

#### Method 2:

Stroke a magnet in one direction along the length of the needle (from the eye end to the point) repeatedly.

#### Method 3:

Heat the needle red hot and allow it to cool in an approximate north-south direction will. Use caution, as moving the red hot needle around to align it may prove difficult and dangerous in a survival situation.

## Constructing the Compass

Once magnetized, the needle needs to be able to pivot freely to locate north.

There are several ways to allow the needle to pivot freely. One method is to float the needle on a liquid. If the needle floats on a liquid such as water it can rotate. A buoyant object (eg, cork, leaf, Styrofoam, plastic cling wrap, etc.) can be used to support the needle on the surface of the water. Surface tension supports a small needle, but any disturbance to the container and the needle will sink.

Another method of allowing the needle to rotate is to attach it to a fine string, cord, long strand of hair, fishing line or other fine cordage. The cordage is attached exactly in the middle of the needle to keep it horizontal. The needle points north when allowed to dangle at the bottom of the cordage. North is found by slowly turning the cordage left or right and observing when the needle is rotating the least. This method proves difficult in windy conditions.

To verify which end of the needle is pointing north, use basic navigational skills (eg, North Star, Sun's position during the day, etc.).

### ACTIVITY

Time: 5 min

#### OBJECTIVE

The objective of this activity is to have the cadets a construct compass.

#### RESOURCES

- sewing needle,
- silk cloth, and
- small magnet.

#### ACTIVITY LAYOUT

Nil.

#### ACTIVITY INSTRUCTIONS

Have the cadets:

1. select a method of magnetizing the needle;
2. magnetize the needle;
3. select a method for allowing the needle to pivot;
4. determine north with the constructed compass; and
5. discuss the process of making a compass.



Cadets using the liquid method should improvise the float and container of water. Cadets using the cordage method should improvise the cordage.

**SAFETY**

Nil.

**CONFIRMATION OF TEACHING POINT 3**

The cadets' construction of an improvised compass will serve as the confirmation of this TP.

**Teaching Point 4****Explain and demonstrate how to construct a hammer.**

Time: 10 min

Method: Demonstration



Using the hammer constructed prior to this lesson, explain and demonstrate how the hammer was made.

A hammer is one of the most basic and fundamental tools. It is perhaps the oldest human tool known. The earliest evidence of stone used as a hammer dates to about 2.4 million years ago. 30 000 years ago, humans adapted handles to stones to create hammers.

A stone can be used as a hammer for driving sticks into the ground, dispatching fish and small animals. If unhandled, the stone fits comfortably in the hand, with the finger tips extending just past the midpoint of the stone. Using smaller stones risks smashing fingers.

To make a split stick hammer, use the following steps:

1. Wrap the handle 15–20 cm from end with cordage.
2. Split the handle to the wrap.
3. Open tines and insert the stone hammer head.
4. Securely lash the stone to the handle.
5. Pull tines together at the top of the stone head and lash securely.

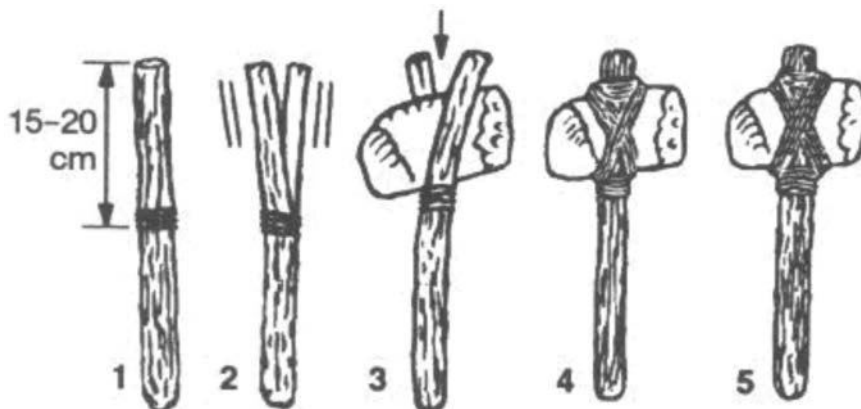

Figure 1 Split Stick Hammer

Note. From *U.S. Army Survival Handbook* (p. 134), by Department of the Army, 2002, Guilford, CT: The Lyons Press.



To make a forked stick hammer:

1. Find a suitable green wood forked branch and trim it to the correct length. Leave the tines long enough to be lashed above the stone.
2. Lash the base of the fork in the stick to prevent it from splitting when the tines are attached above the stone. A groove in the stone will help keep it from moving in use.
3. Set the stone in the crotch of the forked stick and start pulling the tines together with cordage. Secure the tines with cordage.

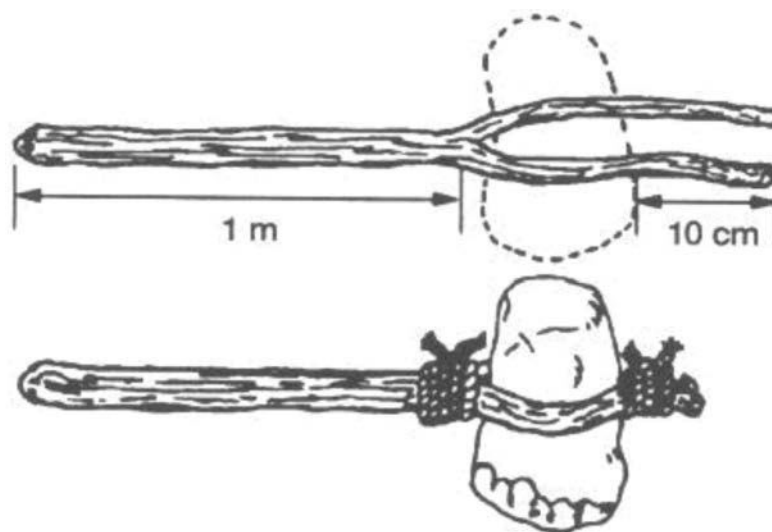

Figure 2 Forked Stick Hammer

*Note.* From *U.S. Army Survival Handbook* (p. 134), by Department of the Army, 2002, Guilford, CT: The Lyons Press.

To make a thinned stick hammer use the following steps:

1. Using a small stone, chip the hammer stone to create a shallow groove around its circumference for the wood to wrap.
2. Shave the end to half the diameter, long enough to wrap around the stone and meet the handle.
3. Wrap the wood around the stone head and lash securely.

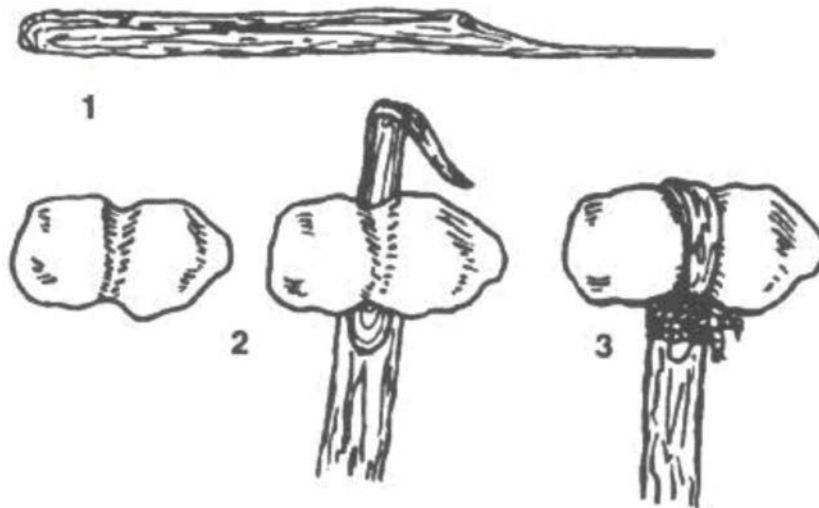

Figure 3 Thinned Stick Hammer

*Note.* From *U.S. Army Survival Handbook* (p. 134), by Department of the Army, 2002, Guilford, CT: The Lyons Press.

Wooden sticks can be attached to a stone to act as a handle. The handle increases the length of the swing radius, increasing the speed of the hammer head and the force delivered to the object being struck. It also keeps the user's hand away from the point of impact and reduces the shock of the blow to the user's hands. It is important to size the handle to the stone and the task. A handle that is too long results in an unwieldy tool and too short is inefficient.

The handle should be carefully constructed from green wood and attached securely to the stone. The diameter of the handle should be the same size as the user's index and middle finger combined. A split stick, Y-shape stick with the tines wrapped around or a stick thinned where it wraps around the stone will be more secure (as illustrated in Figures 1–3). The joint is strengthened by grooving the stone by chipping around its circumference, and lashing using a wet leather thong, wire, strong cordage or sinew for the binding.

Be conscious of the arc of the striking tool. If the stone separates from the handle, it has the potential to strike anything in that arc.

A piece of wood can also be used as a striking implement. The handle sizing remains the same as for a stone hammer. Larger diameter sections of log are reduced in the handle area to the proper handle size. This hammer or club is used either split or cut a piece of wood by hitting the back of the knife held in the opposite hand. This type of hammer or club does not last long in use as the objects being struck are usually wood, stone, or metal, which are harder than the club, causing it to splinter.

---

#### CONFIRMATION OF TEACHING POINT 4

##### QUESTIONS:

- Q1. What are some uses for a stone hammer?
- Q2. How should the stone be attached to the handle?
- Q3. Why will a wooden club not last long?

**ANTICIPATED ANSWERS:**

- A1. A stone can be used as a hammer for driving sticks into the ground, dispatching fish and small animals.
- A2. The stone should be attached to the handle by lashing using a wet leather thong, wire, strong cordage or sinew for the binding
- A3. A hammer or club will not last long in use as the objects being struck are usually wood, stone or metal which is harder than the club, causing it to splinter.
- 

**END OF LESSON CONFIRMATION**

The cadets' improvisation of tools will serve as the confirmation of this lesson.

---

**CONCLUSION**

---

**HOMEWORK / READING / PRACTICE**

Nil.

**METHOD OF EVALUATION**

Nil.

**CLOSING STATEMENT**

The ability to improvise tools using found material can make the task of surviving easier. There will always be material in the area around the survivor. Identifying what they can be used for to assist in a survival situation is an asset.

**INSTRUCTOR NOTES / REMARKS**

Cadets who are qualified Survival Instructor may assist with this instruction.

---

**REFERENCES**

---

A3-016 B-GA-217-001/PT-001 Director Air Operations and Training. (1978). *Down but not out*. Ottawa, ON: Department of National Defence.

THIS PAGE INTENTIONALLY LEFT BLANK



**ROYAL CANADIAN AIR CADETS  
PROFICIENCY LEVEL FOUR  
INSTRUCTIONAL GUIDE**



**SECTION 8**

**EO C490.03 – MOVE A CASUALTY TO SHELTER**

Total Time:

90 min

**PREPARATION**

**PRE-LESSON INSTRUCTIONS**

Resources needed for the delivery of this lesson are listed in the lesson specification located in A-CR-CCP-804/PG-001, *Proficiency Level Four Qualification Standard and Plan*, Chapter 4. Specific uses for said resources are identified throughout the instructional guide within the TP for which they are required.

Review the lesson content and become familiar with the material prior to delivering the lesson.

There is no requirement for a qualified first aid instructor to teach the material contained in this lesson; however, the instructor should be a qualified first-aider.

Samples of improvised stretchers should be fabricated before conducting this lesson to use as examples.

**PRE-LESSON ASSIGNMENT**

Nil.

**APPROACH**

A practical activity was chosen for TP 1 as it is an interactive way to allow cadets to experience emergency scene management skills in a safe, controlled environment. This activity contributes to the development of first aid skills and knowledge in a fun and challenging setting.

A demonstration and performance was chosen for TPs 2 and 3 as it allows the instructor to explain and demonstrate moving a casualty to shelter and fabricating an improvised stretcher while providing an opportunity for the cadets to practice and develop these skills under supervision.

An interactive lecture was chosen for TP 4 to introduce the cadets to assessing the situation and caring for a casualty.

**INTRODUCTION**

**REVIEW**

Nil.

**OBJECTIVES**

By the end of this lesson the cadet shall have moved a casualty to shelter.

## **IMPORTANCE**

It is important for the cadets to be able to perform first aid skills as injuries are a common occurrence in field settings. Having an understanding of moving a casualty to shelter, using proper carrying techniques and improvised stretchers, as well as, performing ongoing care will allow the cadets to take action in an emergency during a survival situation.

---

**Teaching Point 1**

**Conduct an activity where the cadets will practice emergency scene management.**

Time: 15 min

Method: Practical Activity

---



Qualified first-aiders must assist in the conduct of this TP.

## EMERGENCY SCENE MANAGEMENT

### Scene Survey

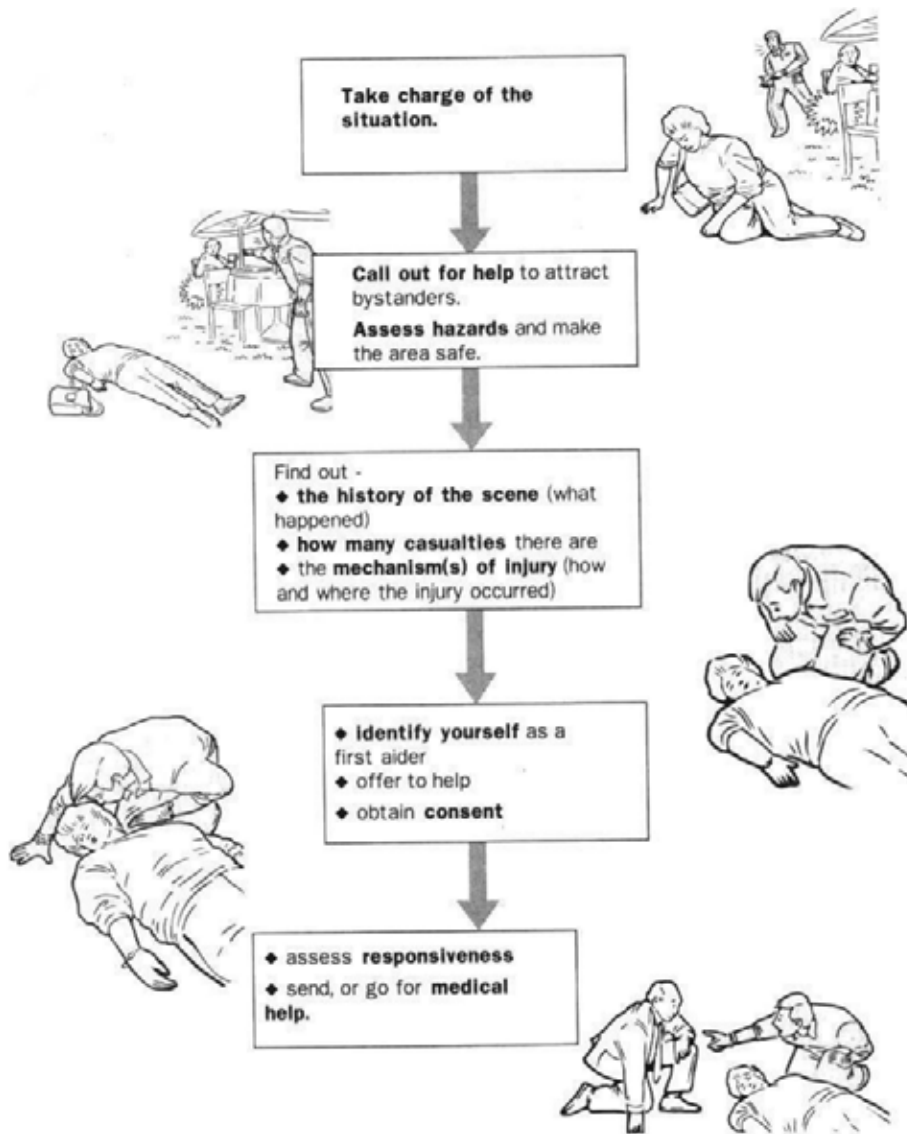

Figure 1 Scene Survey

Note. From *Military First Aid Safety Oriented Basic and Standard Levels Student Reference Guide* (p. 1-12), by St. John Ambulance, 2006, Ottawa, ON: National Defence Headquarters. Copyright 2006 by Priory of Canada of the Most Venerable Order of the Hospital of St. John Jerusalem.



## Primary Survey

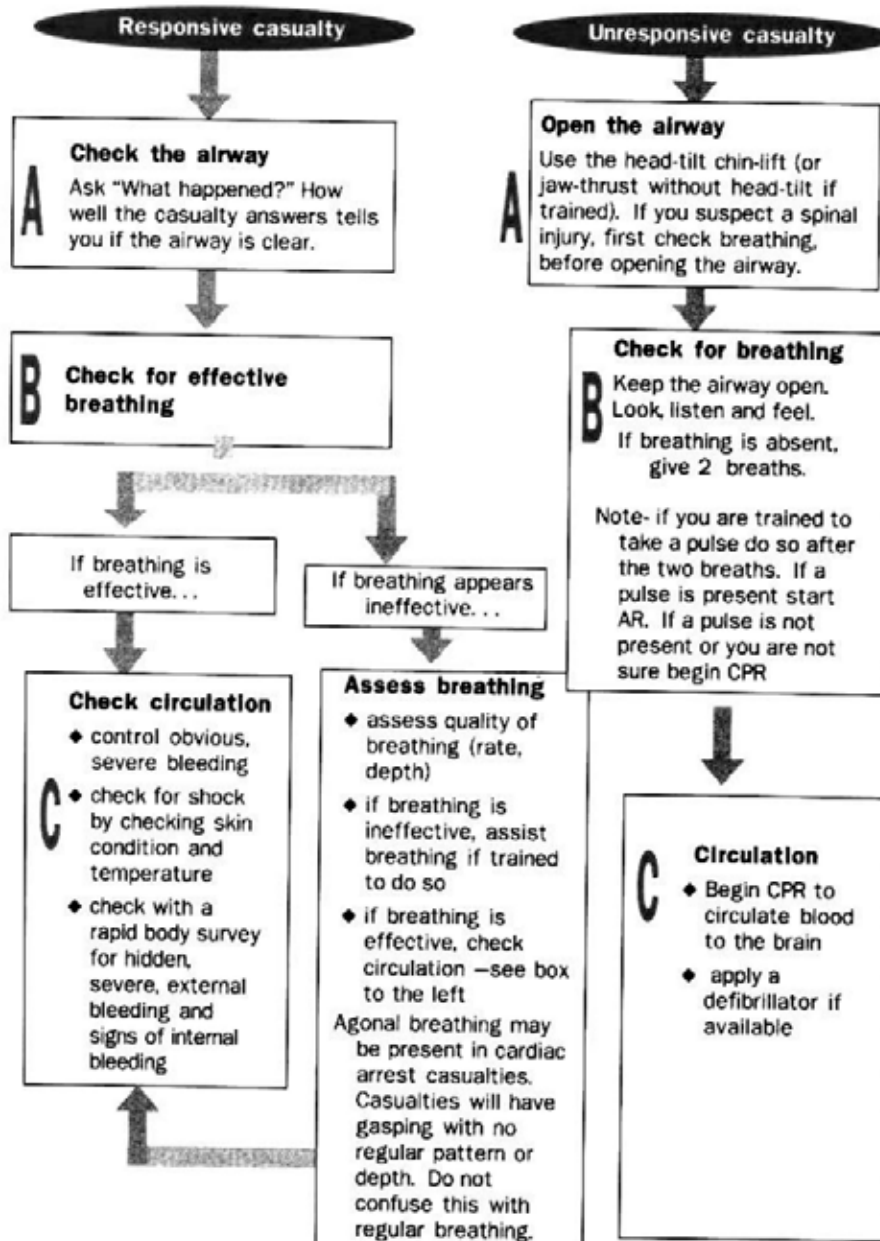

Figure 2 Primary Survey

Note. From *Military First Aid Safety Oriented Basic and Standard Levels Student Reference Guide* (p. 1-13), by St. John Ambulance, 2006, Ottawa, ON: National Defence Headquarters. Copyright 2006 by Priory of Canada of the Most Venerable Order of the Hospital of St. John Jerusalem.

**Secondary Survey**

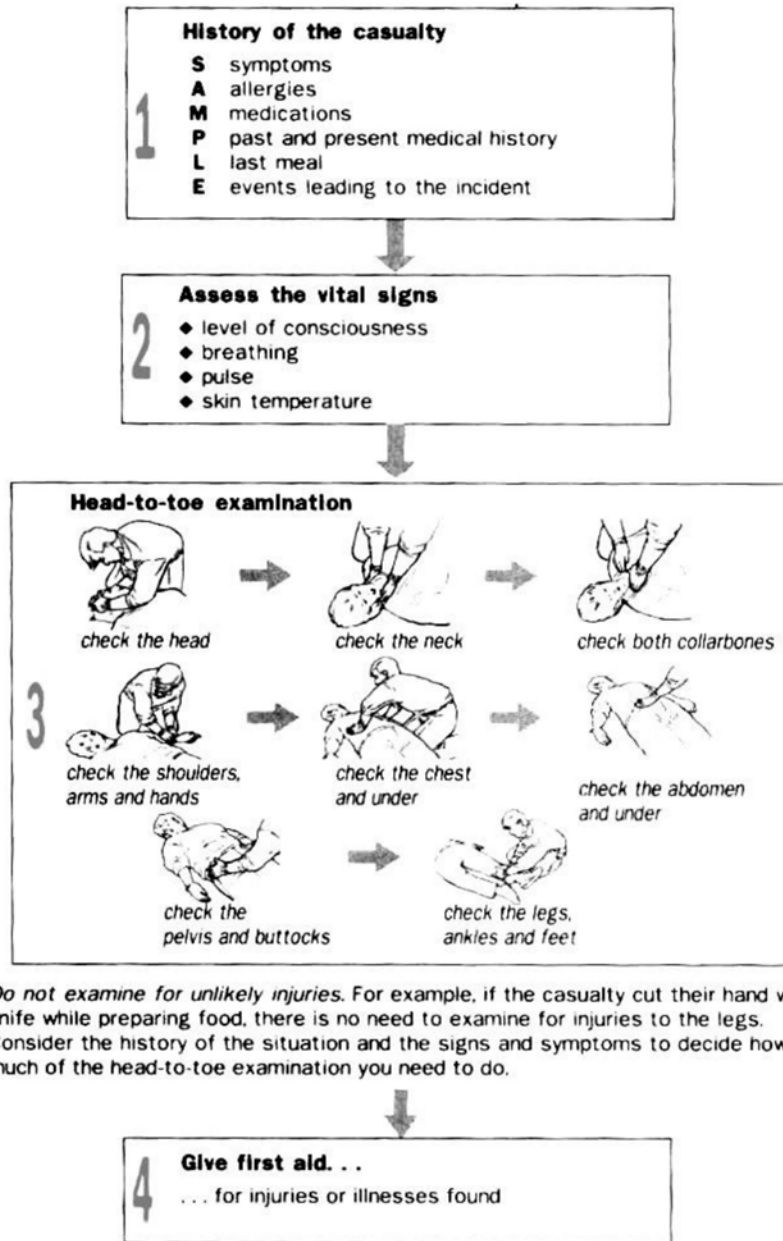

Figure 3 Secondary Survey

*Note. From Military First Aid Safety Oriented Basic and Standard Levels Student Reference Guide (p. 1-14), by St. John Ambulance, 2006, Ottawa, ON: National Defence Headquarters. Copyright 2006 by Priory of Canada of the Most Venerable Order of the Hospital of St. John Jerusalem.*

## Ongoing Casualty Care

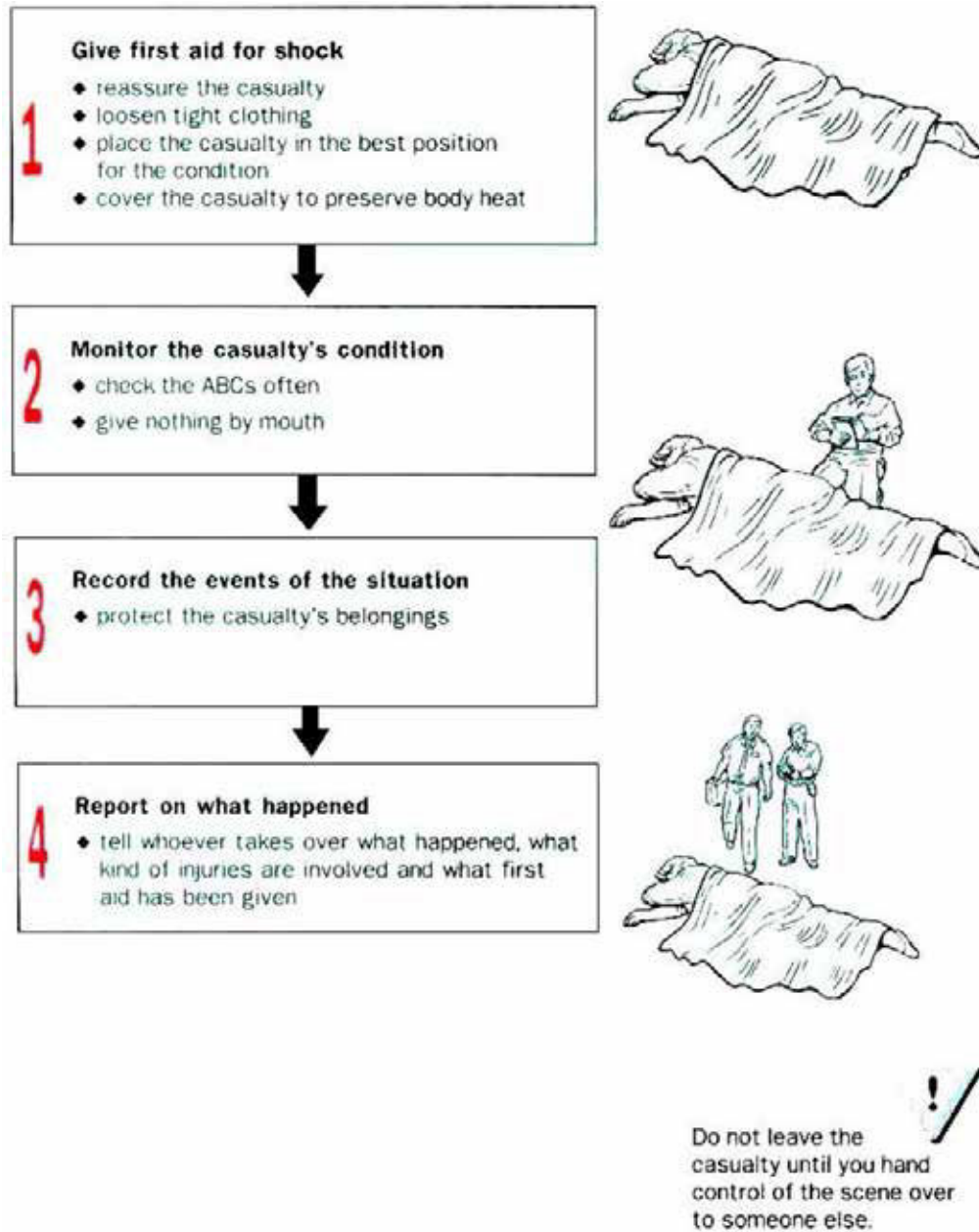

Figure 4 Ongoing Casualty Care

*Note. From Military First Aid Safety Oriented Basic and Standard Levels Student Reference Guide (p. 1-15), by St. John Ambulance, 2006, Ottawa, ON: National Defence Headquarters. Copyright 2006 by Priory of Canada of the Most Venerable Order of the Hospital of St. John Jerusalem.*

---

## ACTIVITY

### OBJECTIVE

The objective of this activity is to have the cadets review emergency scene management.

## RESOURCES

Scenarios located at Attachment A.

## ACTIVITY LAYOUT

Nil.

## ACTIVITY INSTRUCTIONS

1. Divide the cadets into a group of three.
2. Assign a casualty, a first-aider and a bystander for each group.
3. Distribute a scenario to each group.
4. Have the cadets use the steps of emergency scene management to simulate providing first aid to the casualties.
5. Debrief the cadets on their performance during the scenario.



If time allows, cadets may change roles within the group.

## SAFETY

Nil.

---

## CONFIRMATION OF TEACHING POINT 1

The cadets' participation in the activity will serve as the confirmation of this TP.

---

### Teaching Point 2

**Explain, demonstrate and have the cadets, in pairs / groups of three, move a casualty to shelter.**

Time: 20 min

Method: Demonstration and Performance

---



For this skill TP, it is recommended that the instruction take the following format:

1. Explain and demonstrate each carry while the cadets observe.
2. Explain and demonstrate each step required to complete the skill. Monitor the cadets as they imitate each step in pairs / groups of three.
3. Monitor the cadets' performance as they practice the complete skill.

Note: Assistant instructors may be used to assist with carries and monitor the cadets' performance.

## MOVING AND CARRYING OVER SHORT DISTANCES

Many wilderness survival emergencies require moving or carrying a casualty a short distance, with usually only one or two rescuers. It is difficult to carry an adult for any distance and it is easy to injure them further while carrying. The following methods are used to minimize the chance of causing further injury while moving a casualty to shelter.

### Drags

A casualty should be dragged only if they must be moved quickly out of danger, severe cold, strong winds, blowing snow or water. It is important to assess the casualty before attempting a drag because some injuries, if not yet stabilized, may be aggravated by premature movement. If there is only one rescuer, dragging may be the only means of moving a casualty.

When dragging a casualty, observe the following rules:

- Drag a casualty headfirst. This allows the head and neck to be supported and keeps the body straight.
- Keep the body in-line. The casualty's body must not twist or bend. Avoid major bumps.
- The neck should not bend sharply, nor should the head fall forward, back or to the side.

Steps to drag a casualty:

1. If possible, secure the casualty's hands before beginning the drag.
2. Reach under the casualty's body and grip their clothing just below their shoulder on either side while supporting the head and neck using the forearms.
3. Crouch or kneel and walk backwards (as illustrated in Figure 5).
4. Stop when the casualty is out of danger.



This drag is hard on the rescuer's back, so be careful.



Figure 5 Drag

*Note.* From *St. John Ambulance: The Official Wilderness First Aid Guide* (p. 21), by W. Merry, 1994, Toronto, ON: McClelland & Stewart Inc. Copyright 1997 by St. John Ambulance.

5. If the casualty's clothing pulls up too much or tears, place a shirt or jacket over their chest and bring the sleeves under their back to provide a firm grip (as illustrated in Figure 6).



The first-aider can use cuff buttons or Velcro, mitten ties or a piece of cord to assist in this drag.



Figure 6 Modified Drag

*Note. From St. John Ambulance: The Official Wilderness First Aid Guide (p. 21), by W. Merry, 1994, Toronto, ON: McClelland & Stewart Inc. Copyright 1997 by St. John Ambulance.*

### Tarp Drag Method



Rarely should lifts or carries be done on snow because of the possibility of the rescuer slipping; it is safer and easier to drag a casualty on a tarp or sled.

The tarp drag method works well on snow. A rescuer may make a ramp of snow and slide a casualty onto a sled. This drag is also a good way to move a casualty onto insulating material to protect them from the cold ground or snow.

One may wish to leave the tarp under the casualty to aid in another lift. Always put the casualty into a basket stretcher with a backboard, blanket or tarp under them, as it is otherwise difficult to remove them without excessive movement.



Be careful when using the tarp drag method on sloping snow as control may be lost on a downhill slope.

Dragging a casualty on a tarp, blanket, sail, tent or large hide can be accomplished by following these steps:

1. Place the tarp next to the casualty.
2. Fold the tarp into accordion folds of about 1 m (3 feet) wide.
3. Log-roll the casualty by:
  - a. assigning a person to the head, torso, and foot of the casualty;
  - b. having the person at the head of the casualty control the roll and signal the start by counting to the three;
  - c. having the first-aiders roll the casualty towards the person who is at the torso;

- d. placing half of the tarp underneath the casualty while holding them securely on their side;
  - e. having the person at the head of the casualty count to three to signal the other first-aiders to roll the casualty back to their back.
4. Take the tarp that has been coiled underneath the casualty and pull it taut until the tarp is flat.



Figure 7 Rolling Onto a Tarp

*Note.* From *St. John Ambulance: The Official Wilderness First Aid Guide* (p. 21), by W. Merry, 1994, Toronto, ON: McClelland & Stewart Inc. Copyright 1997 by St. John Ambulance.

5. Grip the tarp and hold the casualty's head and shoulders off the ground and drag carefully.



Figure 8 Tarp Drag

*Note.* From *St. John Ambulance: The Official Wilderness First Aid Guide* (p. 21), by W. Merry, 1994, Toronto, ON: McClelland & Stewart Inc. Copyright 1997 by St. John Ambulance.

### **Single-Rescue Carries**

Most single-rescue carries are for short distances and cannot be used to transport a casualty with major injuries. All are extremely strenuous. They are often used to transport casualties with injuries of the lower extremities but care must be taken as it is easy to cause further injuries.



### Packstrap Carry

This is a quick, easy carry for very short distances. The casualty must be able to stand to get into position with their arms across the shoulders like packstraps. Bring the casualty's arms across the shoulders, crossing their wrists in front. Hold their wrists while bending forward and lift the casualty's feet off the ground. Be sure their arms are bent at the elbow.



Figure 9 Packstrap Carry

*Note.* From *St. John Ambulance: The Official Wilderness First Aid Guide* (p. 23), by W. Merry, 1994, Toronto, ON: McClelland & Stewart Inc. Copyright 1997 by St. John Ambulance.

## Piggyback Carry

This familiar carry is good for short-distance transport of conscious casualties with minor injuries and may be used to carry children for long distances.



Figure 10 Piggyback Carry

*Note.* From *St. John Ambulance: The Official Wilderness First Aid Guide* (p. 23), by W. Merry, 1994, Toronto, ON: McClelland & Stewart Inc. Copyright 1997 by St. John Ambulance.

## Carrying Seat

A quick and easy backpack seat to assist the piggyback system may be made with a simple loop of wide strap. It may be necessary to adjust the length once or twice for maximum comfort. This seat is best used if the casualty is lighter than the rescuer, otherwise it may put pressure on the rescuer's neck and shoulders.



Figure 11 Carrying Seat With Wide Strap

*Note.* From *St. John Ambulance: The Official Wilderness First Aid Guide* (p. 23), by W. Merry, 1994, Toronto, ON: McClelland & Stewart Inc. Copyright 1997 by St. John Ambulance.

## CARRYING OVER LONG DISTANCES USING TWO-PERSON CARRIES

Lifting is half as strenuous if there are two rescuers; however carrying for any distance is usually not easier because two carriers must compensate for each other's movements to keep balanced. The chance of error is multiplied with each added person in a lifting team and injury to the casualty often occurs if lifts are poor. Whenever more than one person lifts, observe the following rules:

- One person must be clearly designated as the leader and be responsible for giving all of the commands.
- The partner(s) must be told exactly what is to be done and what the commands will be.
- The lift should first be practiced without the casualty or on an uninjured person.
- Rescuers should maintain eye contact while lifting.

### The Fore-and-Aft Lift and Carry

This should be used only if the casualty has minor injuries. On uneven terrain, it may be the easiest method of lifting a casualty onto a stretcher or another means of transport. As it produces some pressure against the chest, it will restrict the casualty's air flow. Follow these steps:

1. If the casualty is conscious, help them sit up. If the casualty is unconscious, have a partner take the casualty's hands and pull them into the sitting position.

2. Cross the casualty's arms on their chest.
3. Crouch behind them, reach under their arms and grasp the casualty's wrist.
4. Have your partner crouch between the casualty's knees, facing the casualty's feet and take a leg under each arm.
5. At the leader's signal, rise, keeping your back straight.



Figure 12 Fore-and-Aft Lift and Carry

*Note.* From *St. John Ambulance: The Official Wilderness First Aid Guide* (p. 26), by W. Merry, 1994, Toronto, ON: McClelland & Stewart Inc. Copyright 1997 by St. John Ambulance.

### **Two-Hand Seat**

This two-person lift and carry is good for casualties who cannot hold onto the rescuer's shoulders for support, or who are not fully alert.

1. Rescuers crouch on either side of the casualty.
2. Each rescuer will slide one hand under the casualty's thighs and lock fingers over a pad or while wearing mittens or gloves so that fingernails do not dig into each other (as illustrated in Figure 13).

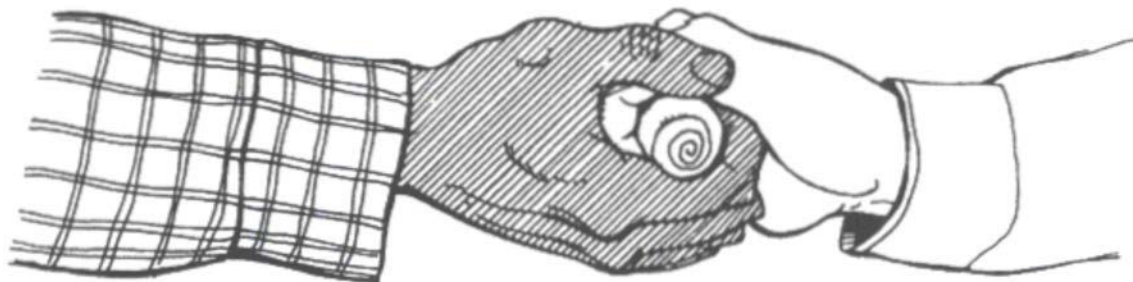

Figure 13 Hand Grip

*Note.* From *St. John Ambulance: The Official Wilderness First Aid Guide* (p. 26), by W. Merry, 1994, Toronto, ON: McClelland & Stewart Inc. Copyright 1997 by St. John Ambulance.

3. Reach across the casualty's back and grip their belt and pants at the opposite hip; the rescuers' arms are crossed (as illustrated in Figure 14).
4. At the leader's signal, raise and step off with the inside foot. This supports the casualty's back; however, the fingers of the gripping hands will tire quickly.



Figure 14 Two-Person Lift

*Note.* From *St. John Ambulance: The Official Wilderness First Aid Guide* (p. 26), by W. Merry, 1994, Toronto, ON: McClelland & Stewart Inc. Copyright 1997 by St. John Ambulance.

For longer carries, try gripping your partner's wrists rather than their fingers. If wearing mittens, gripping the wrist will be more secure than gripping the hand. If the casualty is unconscious, they may be lifted easily to a sitting position. One rescuer pulls on the casualty's hands while the other lifts and supports their head; then the rescuers move into position while supporting the casualty's head and back.



Figure 15 Two-Person Carry

*Note.* From *St. John Ambulance: The Official Wilderness First Aid Guide* (p. 26), by W. Merry, 1994, Toronto, ON: McClelland & Stewart Inc. Copyright 1997 by St. John Ambulance.

---

## CONFIRMATION OF TEACHING POINT 2

The cadets' performing the rescue carries will serve as the confirmation of this TP.

---

## Teaching Point 3

**Explain, demonstrate and have the cadets, as members of a group, fabricate an improvised stretcher.**

Time: 30 min

Method: Demonstration and Performance

---

## FABRICATE AN IMPROVISED STRETCHER

If a person is injured and the situation requires that the casualty be moved, an improvised stretcher may be required. When fabricating an improvised stretcher, follow these steps:

1. **Inventory the available resources.** What materials are available to fabricate a stretcher? Any materials may be used, from natural resources to parts of a downed aircraft. Roots to wiring may be used as cordage and wooden poles to a section of a wing of an aircraft as the frame. Materials that make the casualty comfortable; from spruce boughs to blankets. Examine everything that may be of use.
2. **Fabricate the improvised stretcher.** Once the materials have been gathered, they need to be fabricated into the stretcher. Care should be made to ensure both the strength of the stretcher and the comfort of the casualty.
3. **Test the durability of the stretcher before use.** Before placing the casualty on the stretcher, it should be tested to ensure it is both strong and comfortable. If the stretcher comes apart, dropping the casualty,

it may make a bad situation worse. If the stretcher is not comfortable, it may cause further injury or make the casualty move around, trying to get comfortable, making the stretcher more difficult to carry.



For this skill TP, it is recommended that instruction take the following format:

1. Explain and demonstrate each type of improvised stretcher while the cadets observe.
2. Explain and demonstrate each step required to complete the skill. Monitor the cadets as they imitate each step in groups.
3. Monitor the cadets' performance as they practice the complete skill.

Note: Assistant instructors may be used to assist with fabricating of the improvised stretchers and to monitor the cadets' performance.

## EXAMPLES OF IMPROVISED STRETCHERS

### Pole Stretcher

A very stable stretcher, but the casualty may need to be secured to prevent their sliding off.

### RESOURCES

- Two poles approximately 3 m long,
- 10–12 sticks approximately 60 cm long,
- Cordage, and
- Blanket.

### ACTIVITY INSTRUCTIONS

1. Lay the two long poles approximately 50 cm apart.
2. Using the cordage, tie the short sticks across the gap to create a bed approximately 2 m long.
3. Lay the blanket over the stretcher.
4. Test the stretcher by having one cadet at the head and one cadet at the foot of a volunteer, standing between the poles, using their legs (not their backs), in unison, lift the volunteer.

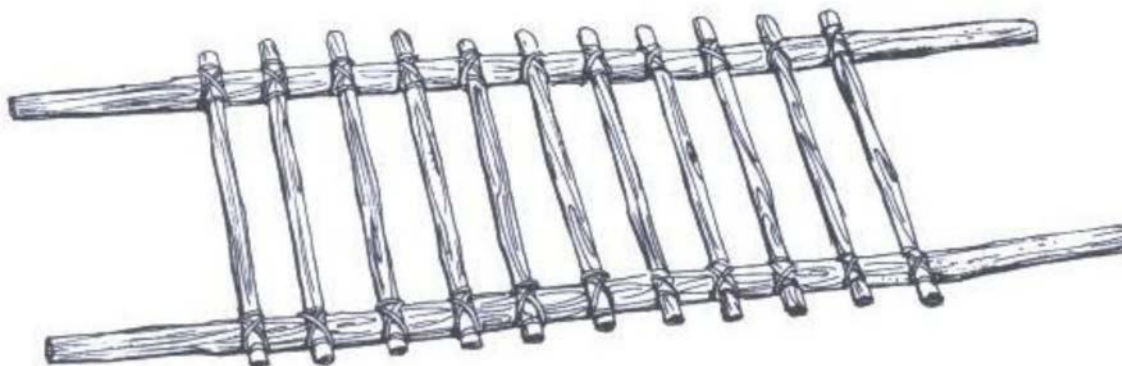

Figure 16 Pole Stretcher

Note. From *St. John Ambulance: The Official Wilderness First Aid Guide* (p. 31), by W. Merry, 1994, Toronto, ON: McClelland & Stewart Inc. Copyright 1997 by St. John Ambulance.



### **Rolled Pole Stretcher**

Easy to fabricate and requires minimal resources. However, there is a possibility of the casualty being compressed within the stretcher, which may cause further injury.

#### **RESOURCES**

- Two poles approximately 3 m long, and
- One tarp.

#### **ACTIVITY INSTRUCTIONS**

1. Lay the casualty on the centre of the tarp.
2. Roll each pole into the tarp, one on each side, parallel to the casualty (see Figure 17).
3. Test the stretcher by having one cadet at the head and one cadet at the foot of a volunteer, standing between the poles, using their legs (not their backs), in unison, lift the volunteer.



Figure 17 Rolled Pole Stretcher

*Note.* From *St. John Ambulance: The Official Wilderness First Aid Guide* (p. 29), by W. Merry, 1994, Toronto, ON: McClelland & Stewart Inc. Copyright 1997 by St. John Ambulance.

### **Shirt Stretcher**

Easy to fabricate and requires minimal resources. However, there is a possibility of the casualty being compressed within the stretcher, which may cause further injury. There is also the possibility of the casualty falling between a gap between two shirts.

#### **RESOURCES**

- Two poles approximately 3 m long, and
- Two to four shirts.

#### **ACTIVITY INSTRUCTIONS**

1. Insert the poles into the sleeves and bodies of the shirts to create a bed approximately 2 m long. Ensure that any fasteners (eg, buttons, zippers) are fastened.
2. Test the stretcher by having one cadet at the head and one cadet at the foot of a volunteer, standing between the poles, using their legs (not their backs), in unison, lift the volunteer.



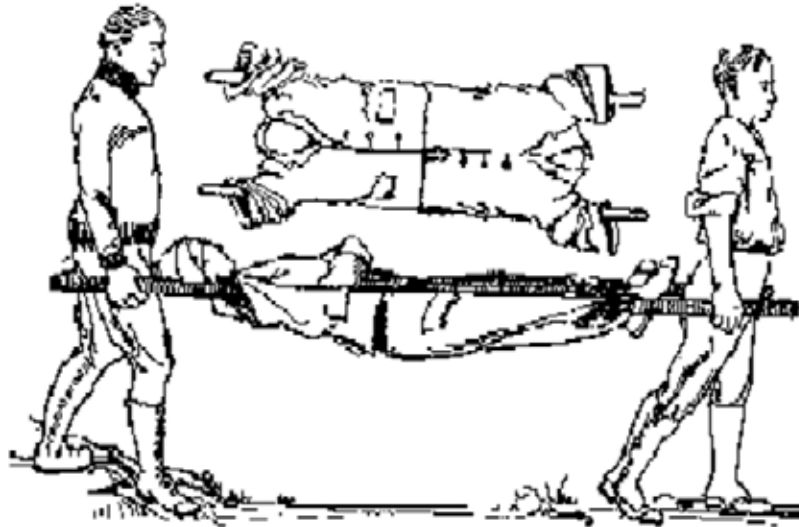

Figure 18 Shirt Stretcher

*Note.* From "Soil and Health Library", by S. Solomon, 2007, *First Aid in Accidents*. Retrieved March 17, 2009, from <http://www.soilandhealth.org/02/0201hyglibcat/020146.lindlahr.nat.therap/Nat.Thera.Pt5.htm>

---

### CONFIRMATION OF TEACHING POINT 3

The cadets' fabricating improvised stretchers will serve as the confirmation of this TP.

---

#### Teaching Point 4

Time: 15 min

**Discuss casualty care.**

Method: Interactive Lecture

---

### DISCUSS CASUALTY CARE

In a survival situation, there may be a long time between administering first aid and getting the casualty to medical help. The first-aider is required to administer ongoing casualty care until rescued / found. The first-aider should focus on the following:

#### Breathing

When someone is inactive deep breaths are rarely, if ever, taken. Shallow breathing may allow fluids and mucus to build up in the lungs. This promotes the growth of bacteria and for the possibility of the casualty catching pneumonia. It is important for the casualty to take deep breaths and to cough, even if it hurts. If the injury permits, place the casualty in a semi-sitting position to make it easier to take deeper breaths / cough. Semi-sitting also makes it easier for the casualty to hold their sides, which may make taking deeper breaths / coughing less painful.

#### Warmth

The body, when injured, uses energy to try to heal itself. This results in less energy to maintain body heat which means an injured person can take twice as long to replace lost body heat.



Never assume that because you are warm, a casualty is also warm.

It is easier to cool a person down than to warm them up, therefore it is better to keep a casualty warm. Keep the casualty dry, if possible wearing layers or in a sleeping bag. Put extra padding / insulation between the casualty's body and the ground. Care must be taken when using clothing that does not breathe as condensation will form from the casualty's body as this will make the inner layers damp, however, it should be used to protect from the rain and the wind.

Rocks warmed by the fire and wrapped in cloth will act as a portable heater; however, ensure that the rock is not as hot as to burn. If the casualty is unconscious, check the casualty often and move / replace the heated rock as required.

### **Body's Position**

Body position may have a profound effect on the casualty. Often, a casualty may want to get into a different position. If the injury is not affected, allow the casualty to get into their own comfortable position. Certain positions will produce specific results, as follows:

- **Recovery position.** This position should be used if the casualty is unconscious, or not fully alert.
- **Semi-sitting position.** This position makes it easier for the casualty to breathe as it reduces the pressure of the abdomen on the lungs.
- **Knees raised position.** This position reduces tension on the chest and abdomen making injuries there less painful.
- **Shock position (on the back with legs slightly raised).** This position is used if the casualty is in shock or faint.
- **Elevation of injured arms / legs.** These positions will help reduce swelling / bleeding to the injured limb.
- **Most comfortable position.** Sometimes it may be necessary to place a casualty into a position that they find to be the most comfortable.

If a casualty maintains the same position for several days, watch out for bedsores. If bedsores develop, treated them the same as an infected wound and do not place the casualty back into the same position. This will only aggravate the treated bedsores.

### **Morale**

Reassurance is important during every moment of a casualty's care. As in a survival situation, fear greatly reduces a person's will to survive. A survival situation combined with an injury multiplies the effect of fear. Ways to maintain a casualty's morale include:

- Staying cheerful and optimistic even if personally discouraged.
- Reassuring the casualty often.
- Always explaining to the casualty what is being done to them.
- Touching the casualty often in an appropriate, comforting and companionable way. Warm human contact is a major part of reassurance.
- Not discussing the casualty's condition in their hearing unless it is optimistic.
- Involving the casualty in their own care by encouraging them to do as much as possible for themselves.
- Keeping the casualty informed of / part of any plans. For example, if someone is leaving the survival site to gather berries, tell the casualty so they do not worry about the possibility that they are being abandoned.

**Rest**

Rest promotes healing, reduces tendencies to bleed or swell, and often reduces pain and stress. Sometimes, pain will prevent adequate rest. If pain medications are available and are used as prescribed, they will help the casualty to rest.

**Fluid Intake**

Maintaining fluid levels is very important, especially for an injured person. Fluids should not be given to a person with internal injuries or who is vomiting. Unfortunately, dehydration over a day or two may cause more damage than small amounts of fluids, even when they are not recommended in normal first aid practice. The following should be considered:

- Give no fluids if the casualty is unconscious, feels nauseated or is vomiting, or has abdominal injuries.
- Give only small amounts at first until it can be determined whether the casualty will vomit or not. Always be ready for vomiting.
- Give small amounts often rather than lots at once. If the casualty can barely swallow, give sips every five or ten minutes.
- If possible, give nutritious fluids. However, do not give alcohol, coffee, tea, hot chocolate or any drinks with caffeine as these are diuretics which increase urine output and increase the possibility of dehydration.
- Give water to any shock, burn or dehydration casualty who can tolerate it.
- Maintain liquid intake of at least five to six litres / day. If there are signs of dehydration, encourage the casualty to drink more.

**Urination**

A person normally urinates about one litre per day. If there is less than expected, suspect shock / dehydration. If the urine is bloody, discoloured, or has a strong smell, record this information. If the casualty's injury prevents them from urinating on their own, improvise a bedpan / urinal. Always try to maintain the casualty's dignity.

**RECORDING ALL OBSERVATIONS**

It is very important to record all observations, including the date and time. Also record what was done (eg, first aid provided, what drunk / eaten, symptoms, vital signs, bowel movements, urination) and when. Be alert to changes as these are signs of changes in the casualty's condition. This information may be of assistance to the medical personnel who will be taking over the care for the casualty.

---

**CONFIRMATION OF TEACHING POINT 4****QUESTIONS:**

- Q1. Describe three (of the five) body positions discussed.
- Q2. What is the importance of rest?
- Q3. Why should all observations be recorded?

## ANTICIPATED ANSWERS:

A1. The six positions discussed:

- **Recovery position.** This position should be used if the casualty is unconscious, not fully alert, or is nauseated and may vomit.
- **Semi-sitting position.** This position makes it easier for the casualty to breathe as it reduces the pressure of the abdomen on the lungs.
- **Knees raised position.** This position reduces tension on the chest and abdomen making injuries there less painful.
- **Shock position (on the back with legs slightly raised).** This position if used if the casualty is in shock or faint. However, if the is breathing problems or a chest / abdominal injury, make sure just the legs, and not the whole body, is raised to reduce pressure on the abdomen / lungs.
- **Elevation of injured arms / legs.** These positions will help reduce swelling / bleeding to the injured limb.
- **Most comfortable position.** Sometimes it may be necessary to place a casualty into a position that they find to be the most comfortable.

A2. Rest promotes healing, reduces tendencies to bleed or swell, and often reduces pain and stress.

A3. Alerts the caregiver to changes as these may be signs of changes in the casualty's condition. This information may be of assistance to the medical personnel who will be taking over the care for the casualty.

---

## END OF LESSON CONFIRMATION

The cadets' moving a casualty to shelter will serve as the confirmation of this lesson.

---

## CONCLUSION

---

## HOMEWORK / READING / PRACTICE

Nil.

## METHOD OF EVALUATION

Nil.

## CLOSING STATEMENT

It is important for the cadets to be able to perform first aid skills as injuries are a common occurrence in field settings. Having an understanding of moving a casualty to shelter, using proper carrying techniques and improvised stretchers, as well as, performing ongoing casualty care will allow the cadets to take action in an emergency during a survival situation.

## INSTRUCTOR NOTES / REMARKS

Cadets who are qualified Survival Instructor or qualified first-aiders in Proficiency Level Four may assist in the conduct of this EO.

The assessment of the casualty in order to move the casualty will be conducted by the qualified first-aider.

Samples of improvised stretchers should be fabricated before conducting this lesson to use as examples.

---

### REFERENCES

---

A0-134 A-MD-050-072/PW-001 Canadian Forces (2006). *Military first aid: Safety oriented: Basic and standard levels: Activity book*. Ottawa: Department of National Defence.

C2-030 ISBN 0-7710-8250-9 Merry, W. (1994). *St. John Ambulance: The official wilderness first aid guide*. Toronto, ON: McClelland & Stewart Inc.

THIS PAGE INTENTIONALLY LEFT BLANK

## **EMERGENCY SCENE MANAGEMENT SCENARIOS**

### **Scenario 1**

A shopper has fallen while slipping on the wet floor and hits his/her head and is unconscious. There is one employee trained in first aid and another shopper is willing to assist until medical help arrives.

### **Scenario 2**

A spectator in an arena falls down a set of stairs. You are a St. John Ambulance volunteer who must respond and perform Emergency Scene Management for the casualty who has suspected head / spinal injuries.

### **Scenario 3**

Three first year cadets are inside of a modular tent during a thunderstorm. The first cadet is leaning against the pole and lightning strikes the tent. The first cadet receives burns to his back. The second cadet is trained in first aid and the third cadet will assist with the casualty until officers and medical help arrives.

### **Scenario 4**

A cadet is using a knife to cut a piece of wood, while the cadet is doing this, another cadet close by bumps into the cadet. The cadet has cut their hand.. A few cadets are in the general area and hear the screams of the two cadets. One of them is trained in first-aid and assists until medical help arrives.

THIS PAGE INTENTIONALLY LEFT BLANK





**ROYAL CANADIAN AIR CADETS  
PROFICIENCY LEVEL FOUR  
INSTRUCTIONAL GUIDE**



**SECTION 9**

**EO C490.04 – PRACTICE SAFE TOOLCRAFT**

Total Time:

90 min

**PREPARATION**

**PRE-LESSON INSTRUCTIONS**

Resources needed for the delivery of this lesson are listed in the lesson specification located in A-CR-CCP-804/PG-001, *Proficiency Level Four Qualification Standard and Plan*, Chapter 4. Specific uses for said resources are identified throughout the instructional guide within the TP for which they are required.

Review the lesson content and become familiar with the material prior to delivering the lesson.

**PRE-LESSON ASSIGNMENT**

Nil.

**APPROACH**

A demonstration and performance was chosen for this lesson as it allows the instructor to explain and demonstrate the skills. The cadets are expected to sharpen a knife and an axe, and to cut wood while providing an opportunity for the cadets to practice the skills under supervision.

**INTRODUCTION**

**REVIEW**

Nil.

**OBJECTIVES**

By the end of this lesson the cadet shall be expected to practice safe toolcraft.

**IMPORTANCE**

It is important for the cadets to be able to safely use tools on an aircrew survival exercise. Tools support aircrew survival training by assisting the cadets in setting up an aircrew survival exercise site, erecting tents and starting fires. The cadets need to know how to safely use tools to prevent accidents.

**Teaching Point 1****Explain, demonstrate and have the cadets handle, pass and store tools.**

Time: 25 min

Method: Demonstration and Performance



For this skill lesson it is recommended that the instruction take the following format:

1. Explain and demonstrate handling, passing and storing tools while the cadets observe.
2. Explain and demonstrate each step required to complete each skill. Monitor the cadets as they imitate each step.
3. Monitor the cadets' performance as they practice the complete skill.

Note: Assistant instructors may be used to monitor the cadets' performance.

**HANDLING TOOLS**

All tools need to be handled with great care and control. For this lesson, focus on the safe handling and passing of a knife, an axe and a bow saw, since these tools are most dangerous when used incorrectly.

These safety considerations should transfer to all other tools that are used during an aircrew survival training exercise.

**Axe**

A blade cover protects the user from injury, the cutting edge from damage and should be used if available. Always carry an axe by its head. Place two fingers on one side, and grip the neck with the other fingers and thumb on the other side. The handle should point horizontally to the ground and the blade should face outward.



Figure 1 Axe

Note. Created by Director Cadets 3, 2009 Ottawa, ON: Department of National Defence.

## Bow Saw

A bow saw has a sharp long blade that should be covered when carrying for long distances. When the bow saw is carried short distances, the carrier should be aware of where the blade is at all times. Keep the blade facing away from the body and hold the handle firmly. It can be carried in hand, with the blade facing down.



Figure 2 Bow Saw

*Note.* Created by Director Cadets 3, 2009 Ottawa, ON: Department of National Defence.

## Shovel

The shovel is to be handled at the upper part of the shaft toward the shoulder when carrying. The shovel blade should be facing the ground with the cutting edge pointing downward.



Figure 3 Spade Shovel

*Note.* Created by Director Cadets 3, 2009 Ottawa, ON: Department of National Defence.

## Knives



Using a knife improperly can cause injuries and damage the knife. It is important to remember what the knife is designed to do. It is not designed to pry. This may damage the tip of the blade. The handle or butt is not a hammer.

A dull knife requires more energy to use and increases the risk of injury.

A knife can assist greatly during a survival situation but it is useless if it is broken by using it as a substitute for another tool.

When handling a knife, practice the following principles:

- Always cut away from the body or limbs, never toward.
- If the knife is dropped, let it fall to the ground as trying to catch it may cause serious injury.
- Never point a knife at anybody.
- If the knife is a fixed blade, always return it to the sheath when not in use.
- If the knife is of the folding variety, keep it folded away when not in use or keep it in a sheath.
- Never walk or run around with an open or unsheathed knife.

Ensure the knife is only used when the user can clearly see what they are doing. Use adequate lighting after dark.



Figure 4 Survival Knife

*Note.* From "Military Pictures", *Gerber Infantry Survival Knife*, Retrieved April 28, 2009, from <http://www.militarypictures.info/weapons/gerber.jpg.html>

## **PASSING TOOLS**

When passing tools that have a sharp edge, adhere to the following steps:

1. The passer communicates the intent to pass the tool.
2. The receiver gives both a verbal response and eye contact that they accept.
3. The passer and the receiver stand facing each other.
4. The passer holds out the tool with both hands and the sharp edge down.
5. The passer waits for the recipient to place both hands on the tool.
6. The passer asks the recipient if they have control.
7. The recipient states that they have control.
8. The passer releases control of the tool.



These steps may seem overstated, but most accidents that occur when passing tools are a result of poor communication. It takes very little force for a sharp tool to severely injure.

## STORING TOOLS

When storing tools, adhere to the following:

- Always clean tools before storing.
- Check tools frequently to ensure they are in operating condition.
- Always choose a tree close to the aircrew survival site to store tools or build a tool shelter.
- Store tools in a common area that is clearly identifiable.
- Mask or store axes and bow saws in a secure case when not in use (as illustrated in Figure 6)
- Keep all tools away from rain, snow and dirt.
- Do not leave an axe or a bow saw embedded in a stump as the sap causes the blade or bit to rust.
- Do not leave tools lying on the ground.
- Tools should not be stored against a tree even for a brief time.
- The user is responsible for the tool from the time it is taken from its case or storage area until it is returned.



Figure 5 Tool Rack

*Note.* From *Scoutmaster, Knots and Pioneering*, Copyright 2007 by Amazon.com, Inc. Retrieved November 18, 2007, from [http://scoutmaster.typepad.com/.shared/image.html?/photos/uncategorized/chip5\\_copy\\_copy.jpg](http://scoutmaster.typepad.com/.shared/image.html?/photos/uncategorized/chip5_copy_copy.jpg)

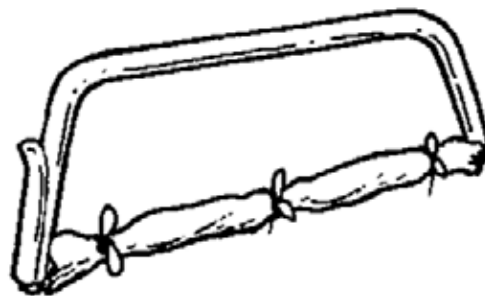

Figure 6 Storing a Bow Saw

*Note* From "Use of Axes and Saws", Copyright 2005 by ScoutBase UK. Retrieved April 28, 2009, from <http://www.scoutbase.org.uk/library/hqdocs/facts/pdfs/fs315070.pdf>

---

## CONFIRMATION OF TEACHING POINT 1

The cadets' participation in handling an axe, a bow saw, a shovel and a knife, and safely passing and storing tools will serve as the confirmation of this TP.



**Teaching Point 2****Explain, demonstrate and have the cadets clean and sharpen a knife and file and sharpen an axe.**

Time: 20 min

Method: Demonstration and Performance



For this skill lesson it is recommended that the instruction take the following format:

1. Explain and demonstrate cleaning and sharpening a knife and an axe while the cadets observe.
2. Explain and demonstrate each step required to complete the skill. Monitor the cadets as they imitate each step.
3. Monitor the cadets' performance as they practice the complete skill.

Note: Assistant instructors may be used to monitor the cadets' performance.

**KNIVES**

To preserve the life of a knife, only use it for its intended purpose. Do not to use blades to pry things, punch holes, as a hammer, or as a screwdriver.

**Cleaning**

To clean a folding knife, open the blade and rinse with warm soapy water and dry well. It may be helpful to scrub it with an old toothbrush. Be careful when handling the knife while the blade is open.

When the knife is completely dry, lightly oil it with machine oil (or cooking oil if the knife is used for food). Wipe off any excess oil and close the blades.

It is important to keep the edge of a knife blade sharp, as a dull knife can be more dangerous than a sharp one. Do not exert too much pressure or use force to make a blade cut through something. By keeping the knife clean, dry and lightly oiled, it will not require sharpening as often.

When sharpening a knife it is important to keep it secure, maintain a uniform sharpening angle on both sides and be careful of cutting fingers. A sharpening stone is most practical for sharpening a knife.

**Sharpening Using a Sharpening Stone and a Honing Stone**

Sharpen a knife as soon as it becomes dull. Use a quality sharpening stone and apply lubricant as specified for the stone. To reshape an edge use a 400 grit sharpening stone. A 1 000 grit sharpening stone and above will sharpen the edge. A honing stone is used to polish the cutting edge and is usually above 2 000 grit. To polish a blade that has stains on it, use wood ash as it will not scratch the blade. Use the following steps when sharpening a knife with a sharpening stone:

1. Apply a light coating of oil (if it is a whetstone or oil stone) to the stone to lubricate and protect the surface. The oil helps keep bits of stone and steel—called slurry—on the surface of the stone. The slurry helps the cutting action of the stone. Ceramic and diamond stones can be used dry or wetted with water.
2. If a combination stone is being used, start with the coarsest grit side.



A hollow ground blade will be sharpened only at the cutting edge at a combined angle 20–30 degrees.

3. To sharpen a hollow ground blade hold the knife with the back edge of the knife off the sharpening stone at 10–15 degrees.
4. To sharpen a flat ground blade, place the bevel flat on the stone. This will register the blade at the proper angle for sharpening.
5. Start where the blade meets the handle and draw the full length of the blade across the stone while moving the blade from one end of the stone to the other. Apply steady pressure. Repeat this eight times on each side.
6. Repeat the process using the fine side of the sharpening stone.
7. Using a honing stone and honing oil, hone the blade, alternate each stroke with the opposite side of the blade for eight strokes maintaining the same angle as before.
8. If a wire edge forms—a thin wire of steel at the very edge of the blade—repeat the same motion on a piece of card board or honing stone until the wire edge falls off.
9. Test for sharpness by cutting something or by looking at the edge of the blade for reflections from unsharpened areas, not by drawing the fingers across the blade.
10. Clean and dry the stone following the manufacturers' instructions.

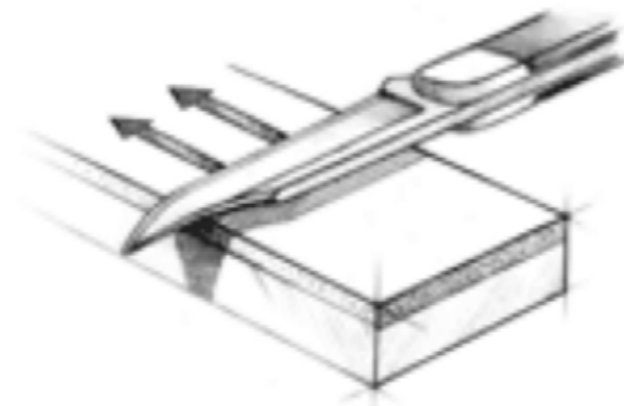

Figure 7 A Sharpening Stone

*Note.* From *Chesapeakeknifeandcutlery.com*, Copyright 2007 by PAX River Enterprises. Retrieved November 19, 2007, from <http://www.chesapeakeknifeandcutlery.com/index.asp?PageAction=Custom&ID=49>

## AXES

If the axe's cutting edge is chipped or misshaped from repeated honing, filing will be necessary. If the edge has the proper profile but is dull, honing is all that is required.

### Filing an Axe Head

Placing the axe in a vice or clamp it securely to a work surface. Facing the axe head, hold the handle of the file with the right hand and the tip of the file with the left hand. Reverse if left handed. Thick leather gloves are



recommended for this procedure. File towards the edge at a 10-degree angle, moving from the top of the blade to the bottom. The file must bite only in the push movement and not to touch the axe when returning to the start position. Only remove enough material to shape the cutting edge. Once a side is done then turn the blade over in the vice and repeat the process.



Figure 8 Filing an Axe

*Note.* From “U.S. Department of Transportation Federal Highway Administration”, 2004, *An Axe to Grind: A Practical Ax Manual*,

### Sharpening Using a Sharpening Stone and Honing Stone

With the axe in the vice, sharpen the edge using a sharpening stone. Use a circular motion starting from the top of the blade to the bottom. Make sure the stone remains in contact with the blade at the proper angle of 20 degrees. Finish sharpening with a honing stone and honing oil to polish the edge, using the same circular motion as with the sharpening stone.



The best way to keep an axe sharp is to use and store it properly. Do not stick it in the dirt or leave it in a tree. Always clean it after each use and apply oil to the blade. Always keep the original shape of the bit and the bevel. An axe that is given the wrong shape and bevel can bounce off the wood uncontrolled.

---

### CONFIRMATION OF TEACHING POINT 2

The cadets' cleaning and sharpening of a knife and filing and sharpening an axe will serve as confirmation of this TP.

**Teaching Point 3****Explain, demonstrate and have the cadets cut wood.**

Time: 20 min

Method: Demonstration and Performance



For this skill lesson, it is recommended that instruction take the following format:

1. Explain and demonstrate how to cut wood using tools skill while cadets observe.
2. Explain and demonstrate each step required to complete the skill. Monitor cadets as they imitate each step.
3. Monitor the cadets' performance as they practice the complete skill.

Note: Assistant instructors may be employed to monitor the cadets' performance.

**SAFE WOOD CUTTING**

An axe and a saw can be dangerous tools if mishandled. If the tools are in a poor condition—either dull, rusted or damaged—they should not be used. Using cutting tools requires proper attitude and concentration. Avoid using tools when tired or angry. Always be conscious of where the blade is.

**Clothing**

Avoid loose clothing, scarves or anything that may become entangled with the tool. Thick leather boots with steel toes are recommended.

**Site**

The site should be clear of ground obstructions and people. Overhanging branches should be trimmed away from the cutting site. Ensure all people know that wood is being cut and that they stay 10 m back. An axe held at arms length will indicate the minimum area that should be cleared for chopping. Cordon off the area used for chopping.

Inspect the axe before use. Do not use an axe if the head and handle do not line up straight, if the handle is split, chipped or otherwise damaged or broken, or if the head is loose. Never use a blunt axe as it can slip or bounce off wood uncontrolled.

**Splitting Wood**

Always use a chopping block below the wood to be chopped and do not let the axe go into the ground. The chopping block should be the largest round available and placed upright so the top surface is level and parallel to the ground.

Chop directly over the chopping block. The part to be cut should be resting at the centre of the chopping block and standing on its own.

Always stop when feeling tired, because there is a greater chance of missing and causing a serious injury.

Use an axe within a marked out chopping area. A bow saw is a safer tool to use away from the chopping area.

The chopping area is out of bounds for anyone not properly clothed or trained.

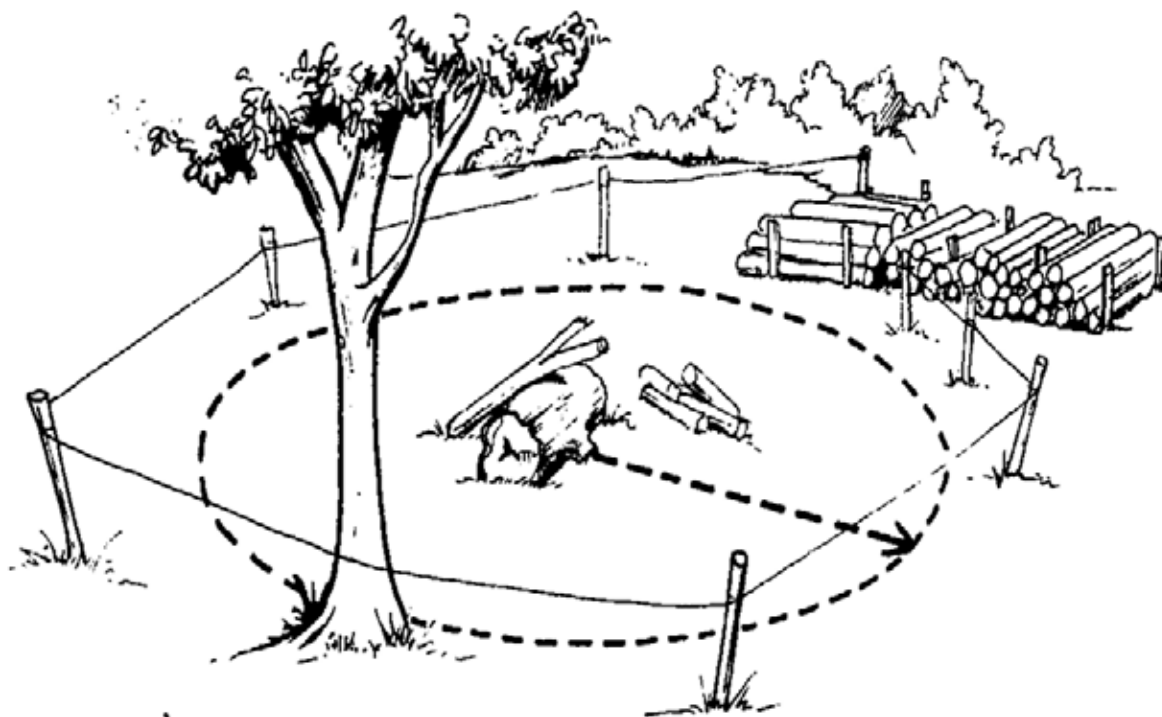

Figure 9 Chopping Area

*Note.* From [Scoutingresources.org/camping](http://www.scoutingresources.org/camping), Copyright 2007 by Scouting Resources.  
Retrieved November 19, 2007, from [http://www.scoutingresources.org.uk/camping\\_axe.html](http://www.scoutingresources.org.uk/camping_axe.html)

## USING AN AXE

### On a Chopping Block



Before starting to use an axe, ensure that there is no one in the chopping area.

To chop wood with an axe:

1. Place a round of wood on the chopping block on its widest end, aligning the round so no knots face the person chopping.
2. Stand facing the chopping, legs spread shoulder width apart, the axe head centred on the chopping block at arms length.
3. Raise the axe above the head and bring it down onto the round. Let the momentum of the swing and weight of the axe do the work. To verify the distance from the block is correct, check the swing by chopping into the chopping block. Adjust the position as necessary.



To split larger logs, use a wedge and a mallet (as illustrated in Figure 15).

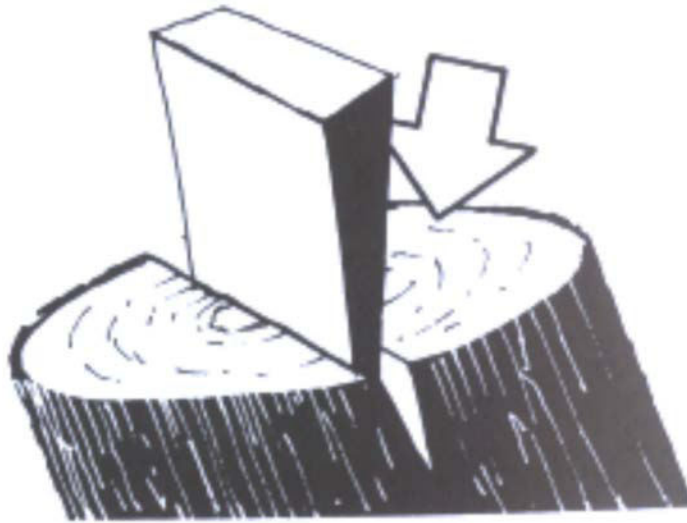

Figure 10 Wedge

*Note.* From *The SAS Survival Handbook* (p. 306), by J. Wiseman, 1999, Hammersmith, London: HarperCollins Publishers. Copyright 1986 by John Wiseman.

## Cutting Logs



Before starting to use an axe, ensure that there is no one in the work area.

To remove branches, chop on the outside of the fork (as illustrated in Figure 11). Make sure to stand on the other side of the log to prevent injury (as illustrated in Figure 12). Always cut towards the tip of the tree.

To chop a log into shorter pieces, stand facing the log, feet wider than shoulder width, axe in hand, arm and axe length from the log. If is too close to the log, the axe head may pass over the log causing the axe handle to strike the log and break. If the person cutting the log is too far from the log, the axe head may strike the ground. Start the cut by striking the log a few times at a 45 degree angle left of the center of the cut. Create a V shape as wide as the log is round. Repeat this on the right side of the center of the cut. Alternate blows to either side of the cut. When possible, cut past the half way point, roll the log over and continue chopping from that side. The final blows should be done with caution as hitting the ground with the axe will dull it immediately.



Figure 11 Removing Branches 1

*Note.* From *The SAS Survival Handbook* (p. 306), by J. Wiseman, 1999, Hammersmith, London: HarperCollins Publishers. Copyright 1986 by John Wiseman.

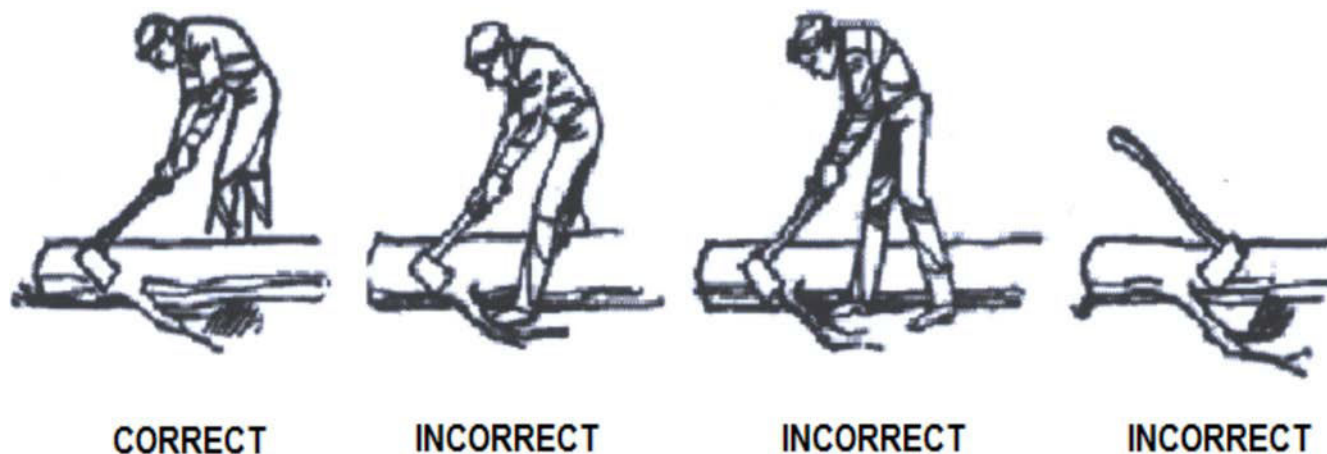

Figure 12 Removing Branches 2

*Note.* From [Scoutingresources.org/camping](http://www.scoutingresources.org/camping), Copyright 2007 by Scouting Resources. Retrieved November 19, 2007, from [http://www.scoutingresources.org.uk/camping\\_axe.html](http://www.scoutingresources.org.uk/camping_axe.html)



Figure 13 Log Chopping 1

*Note.* From *The SAS Survival Handbook* (p. 306), by J. Wiseman, 1999, Hammersmith, London: HarperCollins Publishers. Copyright 1986 by John Wiseman.

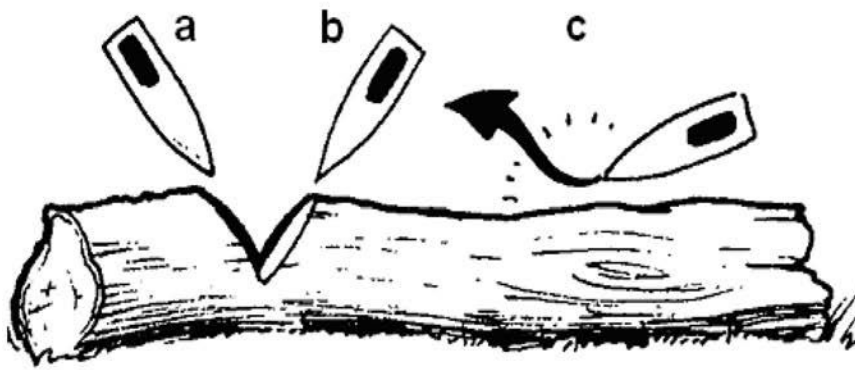

a. First few chops at 45 degrees.

b. Opposite angle chops at 45 degrees.

c. Wrong angle resulting in the axe bouncing off the wood.

Figure 14 Log Chopping 2

*Note.* From [scoutingresources.org/camping](http://scoutingresources.org/camping), Copyright 2007 by Scouting Resources. Retrieved November 19, 2007, from [http://www.scoutingresources.org.uk/camping\\_axe.html](http://www.scoutingresources.org.uk/camping_axe.html)



Always look at the place the axe will hit. When practicing it is a good idea to put a chalk mark on the log and try to hit it.

After each swing make sure to look around and check for people close by.

Clear chippings away regularly and use them for kindling.

### USING A BOW SAW



Before beginning, ensure that there is no one in the immediate area.

A bow saw is an efficient wood cutting tool when used properly. The wood being sawn must be supported so it cannot move. The saw should be held by one hand at the handle just above the blade. The other hand is placed at the top of the bow. The hand holding the handle supplies the power to the stroke. The upper hand guides the saw without applying any downward pressure.

To start the cut, place the saw blade where the wood is to be cut and pull the saw backward. At first it may be difficult to push and pull the blade as very few teeth are in contact with the wood causing the teeth to dig in. As the saw cuts deeper, it will be easier to push and pull as more teeth become supported by the wood. Avoid pushing down on the bow as this will cause the teeth to dig deep into the wood stopping the saw. Maintain rhythm while pushing and pulling. The teeth of the saw blade are set, meaning each tooth is alternately bent to the left or right of the blade. This removes chips wider than the blade preventing the saw from sticking in the wood. Ease up and slow down near the end of the cut.

The diameter of the piece of wood being cut should be less than half the length of the blade. This will allow the wood chips to be pushed clear the kerf (the width of the cut).

Avoid using one hand to hold the wood while sawing with the other. The wood being cut can be held down by a helper.





Always cover the blade of the saw after each use by using either a plastic 'clip-on' mask or tie a length of canvas around the blade.

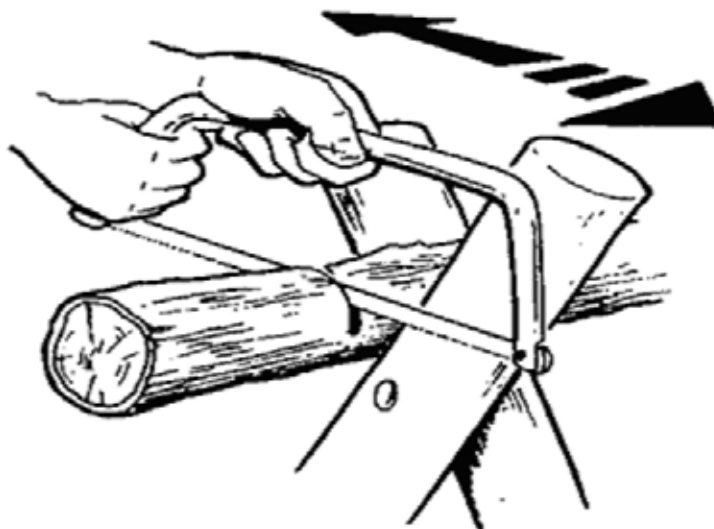

Figure 15 Cutting With a Bow Saw

*Note.* From [scoutingresources.org/camping](http://scoutingresources.org/camping), Copyright 2007 by Scouting Resources. Retrieved November 19, 2007, from [http://www.scoutingresources.org.uk/camping\\_axe.html](http://www.scoutingresources.org.uk/camping_axe.html)

### CONFIRMATION OF TEACHING POINT 3

The cadets' using an axe and a bow saw to cut wood will serve as the confirmation of this TP.

### Teaching Point 4

**Explain, demonstrate and have the cadets use a shovel.**

Time: 15 min

Method: Demonstration and Performance



For this skill lesson, it is recommended that instruction take the following format:

1. Explain and demonstrate the complete skill while cadets observe.
2. Explain and demonstrate each step required to complete the skill. Monitor cadets as they imitate each step.
3. Monitor the cadets' performance as they practice the complete skill.

Note: Assistant instructors may be employed to monitor the cadets' performance.

Ensure that the area where the hole will be dug is marked. Areas with roots and rocks should be avoided.

### DIGGING A HOLE

Place the tip of the shovel on top of the ground. The blade of the shovel should be vertical before digging into the ground. Place one foot on top of the shovel blade and while pushing down, rock the shovel from side to side. Once the blade of the shovel is in the ground pull back 45 degrees to free the soil. If the shovel will not pull back, reposition it around the hole. With one hand midway down the shovel shaft and the other at the top

using the leg muscles, lift the soil from the hole. Place the soil in a pile close to the hole. Continue to dig the hole until it is 30 cm deep into the ground.

### **FILLING THE HOLE**

Holes that are no longer needed should be filled in. To fill the hole, push the blade of the shovel into the soil and then lift the soil into the hole. Repeat until the hole is filled. Pack the soil down to make the soil even with the rest of the earth. Sod should be replaced and the area groomed to remove all signs of the hole.

---

### **CONFIRMATION OF TEACHING POINT 4**

The cadets' participation in using a shovel to dig a hole and to fill a hole will serve as the confirmation of this TP.

---

### **END OF LESSON CONFIRMATION**

The cadets' practicing of safe toolcraft will serve as the confirmation of this lesson.

---

### **CONCLUSION**

---

### **HOMEWORK / READING / PRACTICE**

Nil.

### **METHOD OF EVALUATION**

Nil.

### **CLOSING STATEMENT**

It is important for the cadets to be able to use tools on an aircrew survival exercise. Tools support aircrew survival training by assisting in setting up a field exercise, erecting tents, starting fires. The cadets need to know how to safely use and care for tools to prevent accidents.

### **INSTRUCTOR NOTES / REMARKS**

Sharpening should only be done under close supervision of trained staff members, to prevent unnecessary damage to the equipment and injury to cadets.

Cadets who are qualified Survival Instructor may assist with this instruction.

---

### **REFERENCES**

C3-002 ISBN 0-00-653140-7 Wiseman, J. (1999). *The SAS survival handbook*. Hammersmith, London: HarperCollins Publishers.

C3-003 ISBN 1-896713-00-9 Tawrell, P. (1996). *Camping and wilderness survival: The ultimate outdoors book*. Green Valley, ON: Falcon Distribution.





**ROYAL CANADIAN AIR CADETS**  
**PROFICIENCY LEVEL FOUR**  
**INSTRUCTIONAL GUIDE**



**SECTION 10**

**EO C490.05 – NAVIGATE A ROUTE USING A MAP AND COMPASS**

Total Time:

120 min

**PREPARATION**

**PRE-LESSON INSTRUCTIONS**

Resources needed for the delivery of this lesson are listed in the lesson specification located in A-CR-CCP-804/PG-001, *Proficiency Level Four Qualification Standard and Plan*, Chapter 4. Specific uses for said resources are identified throughout the instructional guide within the TP for which they are required.

Review the lesson content and become familiar with the material prior to delivering the lesson.

Learning stations are a form of group work, where the cadets will be learning by demonstration and performance. When setting up learning stations, ensure that there is enough room for each cadet to be comfortable, and adequate space to work with the equipment. When cadets arrive at a learning station, all materials shall be available. These stations should be placed closely together to minimize time for movement; however far enough apart to avoid interruptions from other groups. For this lesson, four learning stations are required: one station for TPs 1 and 2 and one station each for TPs 3–5.

Based on the topographical map being used, create:

- a list of 10 conventional signs, to be used for TP 2;
- a list of 20 conventional signs for the cadets to determine four- and six-figure grid references (GRs), and a list of 20 four- and six-figure GRs for the cadets to determine the conventional signs, to be used for TP 3;
- two sets of GRs (one set for point-to-point and one set for along-a-route) for the cadets to measure distance on a map, to be used for TP 4;
- a set of GRs for the cadets to determine the bearing on a map, to be used for TP 4; and
- a 100-m straight flat course used to determine personal pace, to be used for TP 5.

A reconnaissance (recce) of the exercise area should be made to determine a site with several distinctive features to be used as prominent objects, to create a bearing course to be used for TP 5.

Create 4–6 three-leg map and compass courses to be used for TP 6. Each course will be listed as a set of four 6-figure GRs (the start point and the endpoint of each leg). Total length of each course should not exceed 2 km.

Determine a safety bearing in the event any groups become disoriented or lost.

**PRE-LESSON ASSIGNMENT**

Nil.

## **APPROACH**

A practical activity was chosen for this lesson as it is an interactive way for the cadets to review the compass, topographical maps, GRs, distance on the map and on the ground, bearings on the map and on the ground, and to navigate a route using a map and compass in a safe and controlled environment. This activity contributes to the development of navigation skills and knowledge in a fun and challenging setting.

---

## **INTRODUCTION**

---

### **REVIEW**

Nil.

### **OBJECTIVES**

By the end of this lesson the cadet shall navigate using a map and compass.

### **IMPORTANCE**

It is important for cadets to navigate using a map and compass because it allows cadets another opportunity to practice skills learned in Proficiency Level Three.



Divide the cadets into four groups. Have the groups rotate between four learning stations: one station for TPs 1 and 2 and one station each for TPs 3–5. After the groups have been to all four stations, have them rendezvous at the designated location for TP 6.

### Teaching Point 1

**Review the compass.**

Time: 10 min

Method: Practical Activity

## BACKGROUND KNOWLEDGE

### PRINCIPLES BEHIND THE WORKINGS OF A COMPASS

Regardless of intended purpose or complexity of construction, most compasses operate on the same basic principle. A small, elongated, permanently magnetized needle is placed on a pivot so that it may rotate freely on the horizontal plane. The earth's magnetic field, which is shaped approximately like the field around a simple bar magnet, exerts forces on the compass needle causing it to rotate until it comes to rest in the same horizontal direction as the magnetic field. Over much of the earth this direction is roughly running between north and south, which accounts for the compass's importance in navigation.

The earth has a north and south magnetic pole. These magnetic poles correspond roughly with the actual geographical poles. The north magnetic pole is located (2005 estimate) at approximately 82.7 degrees N latitude and 114.4 degrees W longitude, which lies over 800 km from the north geographic pole.

The horizontal force of the magnetic field, responsible for the direction in which a compass needle is oriented, decreases in strength as one approaches the north magnetic pole. This decrease is due to the lines of force changing direction towards the vertical as they bend back into the earth at the north magnetic pole towards the south magnetic pole. The compass starts to behave erratically, and eventually as the horizontal force decreases even more, the compass becomes unusable.

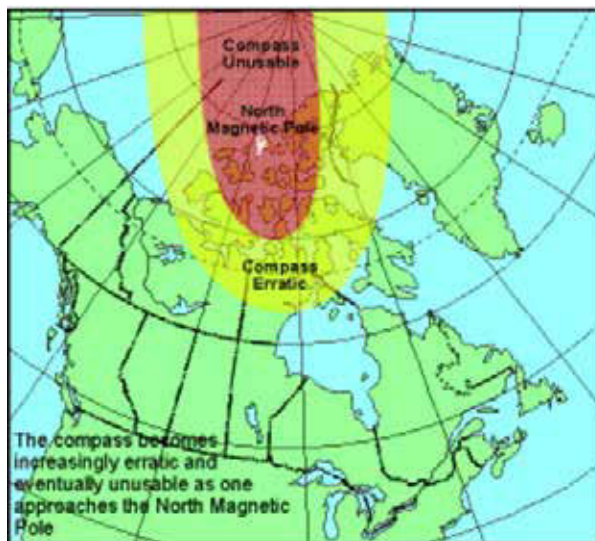

Figure 1 Earth's Magnetic Field

*Note.* From *Royal Canadian Army Cadet Reference Book* (p. 5-33), by Director Cadets 3, 2003, Ottawa, ON: Department of National Defence.

The nature of the earth's magnetic field is such that the magnetic north pole shifts geographic position about 5–10 km per year. Natural phenomena, like earthquakes, may also shift the magnetic field.

### **PARTS OF THE COMPASS**

**A - Sight.** Located at the top of the compass cover. Used to align on an object when taking a bearing or to observe one along a given bearing.

**B - Compass cover.** Protects the compass dial and houses the sighting mirror.

**C - Sighting mirror.** Used to see the compass dial while taking a bearing.

**D - Sighting line.** Used when aligning an object or observing along a bearing.

**E - Luminous index point.** At the top of the compass dial and where a bearing is set or read from.

**F - Compass dial.** Houses the magnetic needle, the orienting arrow, the meridian lines, the declination scale (on the inside) and the dial graduations (on the outside).

**G - Dial graduations.** The compass dial is graduated in 2-degree divisions from 0 to 360 degrees. The dial is rotated by hand.

**H - Orienting arrow.** The black and red orienting arrow is located inside the compass dial and is used to line up with the magnetic needle when taking a bearing on the ground. The orienting arrow is what is adjusted when the magnetic declination is set.

**I - Romer 1 : 25 000.** Used to measure six-figure grid references (GRs) on maps with a 1 : 25 000 scale.

**J - Compass base plate.** A clear piece of flat plastic to which the cover, dial and lanyard are attached.

**K - Declination scale.** Used when adjusting the orienting arrow and while setting the magnetic declination for the map being used. It is graduated in 2-degree divisions.

**L - Compass meridian lines.** Black or red lines inside the compass dial. They are used to line up the compass dial with the grid lines (eastings) on a map.

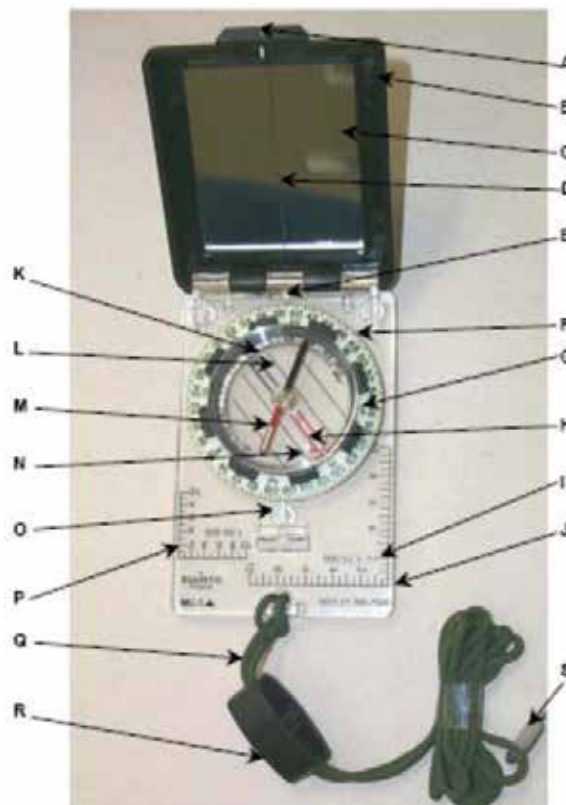

Figure 2 Compass

*Note. From Royal Canadian Army Cadet Reference Book (p. 5-33), by Director Cadets 3, 2003, Ottawa, ON: Department of National Defence.*

**M - Magnetic needle.** Spins freely and points towards magnetic north. The south end of the compass needle is black and the north end, with a luminous patch, is red.



When the magnetic needle is lined up in the red end of the orienting arrow, the mnemonic device "Red in the Bed" is used to remember that the red end of the needle belongs in the red end of the arrow.

**N - Luminous orienting points.** There are two luminous orienting points located on either side of the red end of the orienting arrow.

**O - Luminous index point.** At the bottom of the compass dial; where a back bearing is read from.

**P - Romer 1 : 50 000.** Used to measure six-figure GRs on maps with a 1 : 50 000 scale.

**Q - Safety cord or lanyard.** Used to fasten the compass to the wrist (never around the neck).

**R - Adjustable wrist lock.** Used to attach the compass to the wrist.

**S - Screwdriver.** Located at the end of the safety cord and is used to turn the screw to adjust the orienting arrow's position on the declination scale.

**T - Declination adjusting screw.** Located on the back side of the compass dial and is used to adjust the orienting arrow's position on the declination scale.

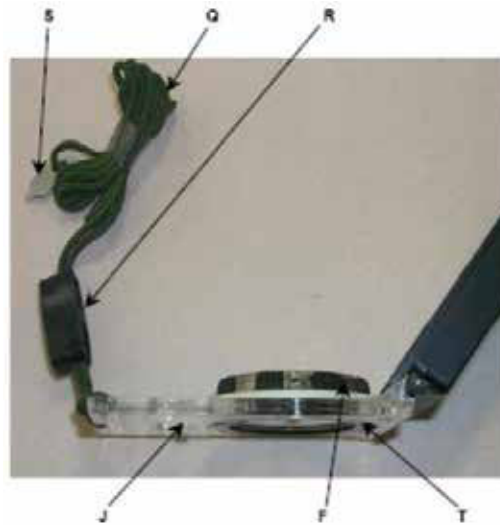

Figure 3 Compass

*Note. From Royal Canadian Army Cadet Reference Book (p. 5-34), by Director Cadets 3, 2003, Ottawa, ON: Department of National Defence.*



After being exposed to a strong light source, the luminous parts of the compass will glow in the dark making operating the compass at night possible.

## HOW TO SET A PREDETERMINED DECLINATION

### Declination

Magnetic declination is the difference in bearing either between grid north and magnetic north or between true north and magnetic north. Declination will change for each topographical map and it also changes annually due to the shifting north magnetic pole.



Cadets will almost always use the magnetic declination value between grid north and magnetic north (grid declination) when navigating using a map and compass. By setting the magnetic declination on the compass, magnetic bearings are converted to grid bearings which allow bearings taken from the map to be used on the ground and vice versa.

Declination is further described by stating whether the declination is east or west of magnetic north. The declination for the map being used is calculated using the information in the declination diagram (as illustrated in Figure 4) found in the marginal information of the map.



Declinations are stated in degrees and minutes. Each degree is subdivided into 60 minutes. This is important when setting the declination as the declination scale is graduated in 2-degree divisions.



Use diagram only to obtain numerical values  
 APPROXIMATE MEAN DECLINATION 1982  
 FOR CENTRE OF MAP  
 Annual change (increasing) 4.4'

N'utiliser le diagramme que pour obtenir les valeurs numériques.  
 DÉCLINAISON MOYENNE APPROXIMATIVE  
 AU CENTRE DE LA CARTE EN 1982  
 Variation annuelle (croissante) 4.4'

Figure 4 Declination Diagram

*Note.* From *Royal Canadian Army Cadet Reference Book* (p. 5-39), by  
 Director Cadets 3, 2003, Ottawa, ON: Department of National Defence.

### Adjusting the Declination on a Compass

The compass's declination scale must be set to compensate for the difference between grid north and magnetic north. To do this, first have the amount of declination in degrees east or west. Then, turn the compass over and look at the back of the dial.

From the zero point, using the screwdriver, turn the declination adjusting screw to the right for west and to the left for east declination (as illustrated in Figure 5). Each small black line represents two degrees of declination.



When setting declination on a compass, it is easier to hold the screwdriver and turn the compass, especially in cold weather. The declination shall never be turned past the last number of the declination scale.



Figure 5 Declination Scale and Screw

*Note.* Created by Director Cadets 3, 2008, Ottawa, ON: Department of National Defence.



If a person were to follow a compass bearing for 1 km without first adjusting for declination, for every one degree of declination, that person would be over 17 m to the left or right of their plotted bearing. This is how important declination is.

---

### ACTIVITY

Time: 5 min

#### OBJECTIVE

The objective of this activity is to have the cadets name a part of the compass and describe its purpose.

#### RESOURCES

Compasses.

#### ACTIVITY LAYOUT

Nil.

#### ACTIVITY INSTRUCTIONS

1. Hand out the compasses to the cadets.
2. Ask the cadets to describe how a compass works.
3. Point to a part of the compass and have a cadet name it and describe its purpose.
4. Rotate through all the cadets.

#### SAFETY

Nil.



---

## ACTIVITY

Time: 5 min

### OBJECTIVE

The objective of this activity is to have the cadets set four different magnetic declination values on a compass.

### RESOURCES

- Compasses, and
- Predetermined declinations, to include:
  - 8 degrees W,
  - 15 degrees E,
  - 3 degrees 30 minutes E, and
  - 9 degrees 45 minutes W.



When verifying the declinations set by the cadets, the line at the end of the orienting arrow should be:

- 8 degrees W: directly over the fourth graduated line to the left of the zero mark.
- 15 degrees E: halfway between the seventh and eighth graduated line to the right of the zero mark.
- 3 degrees 30 minutes E: three quarters of the way from the first towards the second graduated line to the right of the zero mark.
- 9 degrees 45 minutes W: to the right of and beside the fifth graduated line to the left of the zero mark.

### ACTIVITY LAYOUT

Nil.

### ACTIVITY INSTRUCTIONS

1. Review magnetic declination.
2. Give the cadets a declination value.
3. Have the cadets turn the compass over (on its back with the declination adjusting screw facing up).
4. Have the cadets grasp the screwdriver attached to the safety cord / lanyard.
5. Using the screwdriver, have the cadets turn the declination adjusting screw to the right for west and to the left for east declination values and set the given declination.
6. Check the set declination.
7. Have the cadets repeat Steps 2–6 for each of the predetermined declinations.
8. Have the cadets set the declination to zero before returning the compasses.

## SAFETY

Nil.

---

## CONFIRMATION OF TEACHING POINT 1

The cadets' participation in the activities will serve as the confirmation of this TP.

---

### Teaching Point 2

**Review topographical maps.**

Time: 10 min

Method: Practical Activity

---

---

## BACKGROUND KNOWLEDGE

---

### MARGINAL INFORMATION

The margins provide information important to the understanding and use of the map. Before using an unfamiliar map, it is important to have a good look at the information contained in its margins. The layout and contents of the marginal information is normally in the same place for all topographical maps, but will always be found within the margins. This information includes:

**Name of map sheet.** For ease of reference, the name of the map is usually a major community or district located on the map (found at the bottom centre of the margin, as well as in the top or bottom right corner).

**Number of the map and index of adjoining maps.** A diagram showing the position of the map sheet in relation to adjoining sheets is shown near the lower right-hand margin. The diagram shows the sheet numbers of the adjoining sheets and accentuates the sheet in hand.

**Date of map data.** Helps to indicate the amount of change that may have occurred since the map was printed (found in the bottom left corner).

**Map scale.** Indicates the scale of the map, most commonly 1 : 25 000 or 1 : 50 000. Scale is used to represent distances on the map in direct relation to the ground. On a 1 : 50 000 scale map 1 cm on the map represents 50 000 cm (500 m) on the ground.

**Scale bars.** Used as a measuring aid for determining distance on the map (found bottom centre below the map name). The left end of the scale bars is divided into tenths for measuring distances more accurately.

**Contour interval.** Indicates the vertical (height) interval between contour lines and is given in metres or feet. The contour interval is found in the bottom margin.

**Legend of conventional signs.** A table showing the conventional signs used on the sheet in their correct colours with their descriptions is shown in the bottom or side margin, plus in a more complete list on the back of the map.

**Military index number.** The index is found in the top right corner of the map sheet and used for ordering additional maps.

**Declination diagram.** Contains the information for the map on how true, grid, and magnetic north relate to each other. This information is given in the form of a diagram with explanatory notes. The diagram is in the right side margin.

**Universal Transverse Mercator grid system (UTM).** The UTM grid system divides the earth's surface into zones, each covering six degrees of longitude and eight degrees of latitude. The 60 longitude bands are

numbered and the 20 latitude bands are lettered. Each grid zone is one rectangle of the grid pattern, established by the bands and designated by the figures of the longitude band followed by the letter of latitude band.

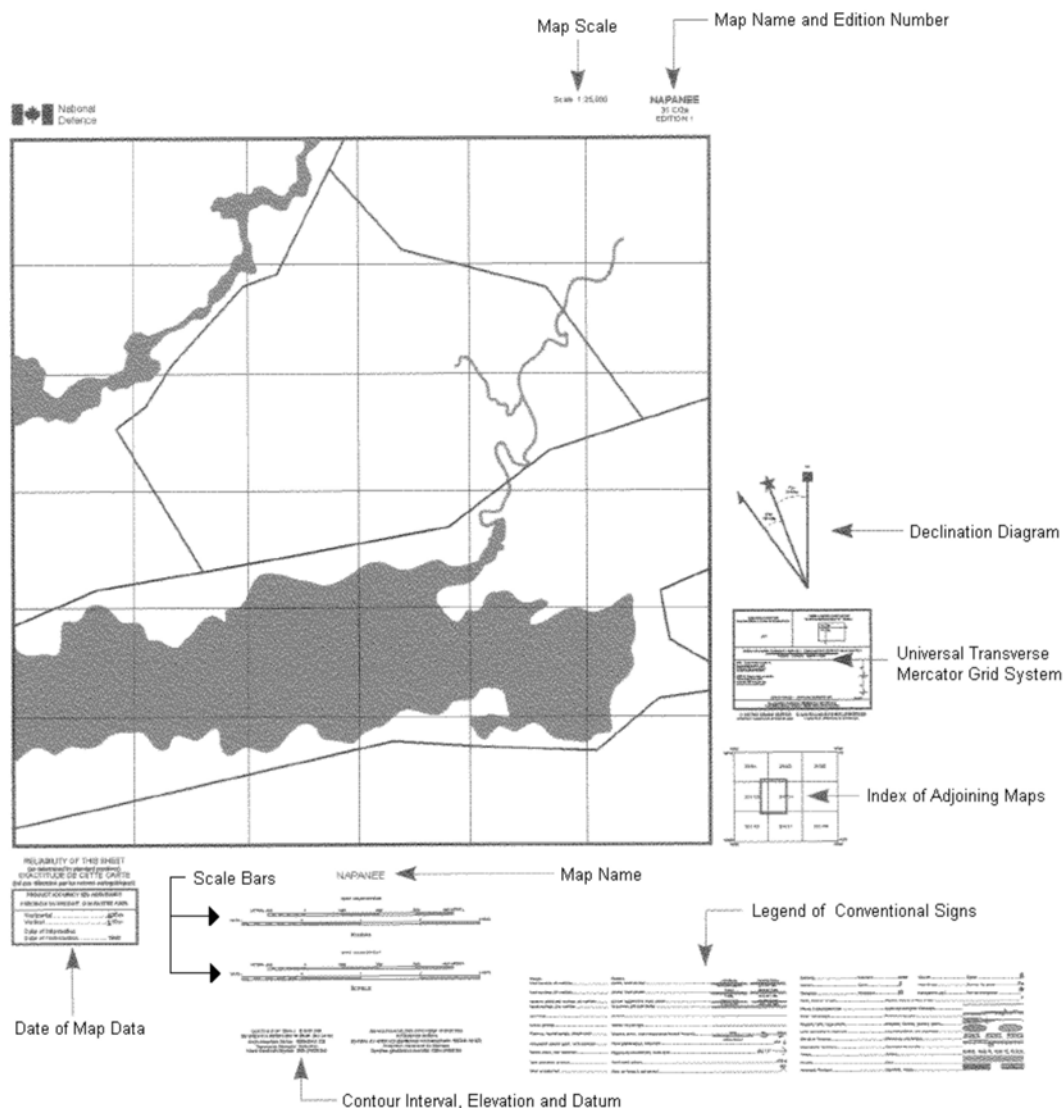

Figure 6 Marginal Information

Note. From *Maps, Field Sketching, Compasses and the Global Positioning System* (p. 11), by Directorate of Army Doctrine 8, 2006, Ottawa, ON: Copyright 2006 by Her Majesty the Queen in Right of Canada.

Military users, refer this map as:	SERIES <b>A901</b> MCE 320 EDITION 1
------------------------------------	--------------------------------------

Figure 7 Military Index Number

Note. From *Maps, Field Sketching, Compasses and the Global Positioning System* (p. 12), by Directorate of Army Doctrine 8, 2006, Ottawa, ON: Copyright 2006 by Her Majesty the Queen in Right of Canada.

### CONVENTIONAL SIGNS

A number of symbols are used to indicate an object or item of detail that cannot be shown either by outline or by a line symbol. Most have been established through long usage and standardization agreements. The meaning of most symbols is obvious. However, if there is doubt, consult the table of conventional symbols located on every map. Located on the back of most maps will be a chart listing many additional conventional signs.

Map-reading not only involves the ability to interpret the symbols shown on the map and to understand the information given in pictorial or written form, but it also involves a true understanding of the ground portrayed and an appreciation of the reliability and value of the particular map being used.

Where the symbol may have more than one meaning, the sign or symbol will be accompanied by a descriptive word (eg, tank or tower).

The use of colour aids in distinguishing details.

**Red.** Used to identify paved roads and highway numbers. Red is also used to shade in areas of urban development.

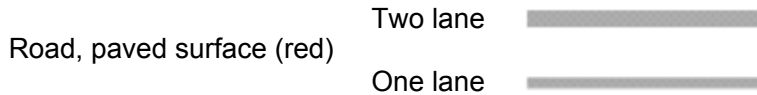

Figure 8 Red Conventional Signs

*Note.* Created by Director Cadets 3, 2008, Ottawa, ON: Department of National Defence.

**Orange.** Used to represent unpaved roads.

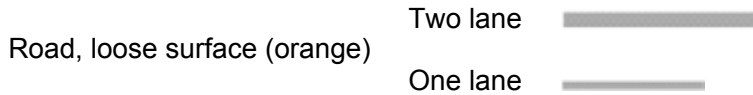
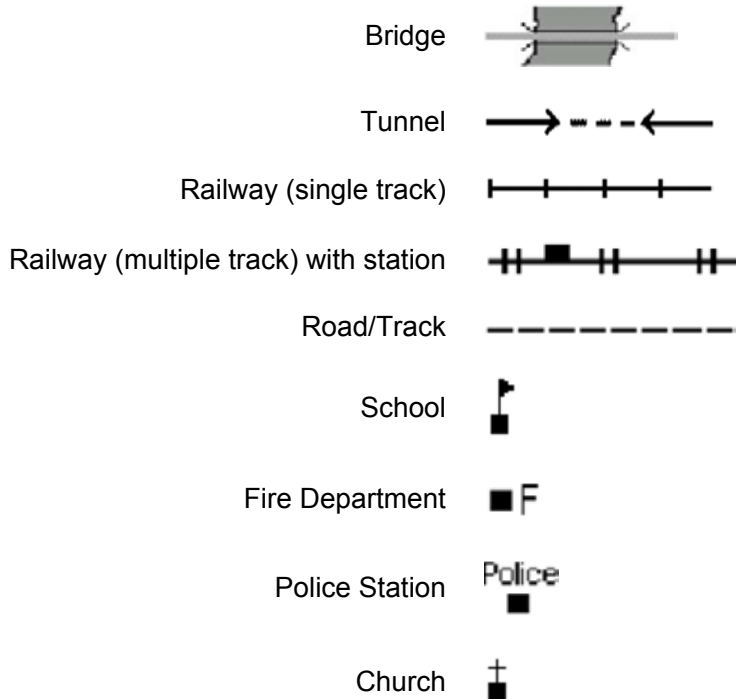

Figure 9 Orange Conventional Signs

*Note.* Created by Director Cadets 3, 2008, Ottawa, ON: Department of National Defence.

**Black.** Used for cultural features, toponyms (place names), some symbols and precise elevations.



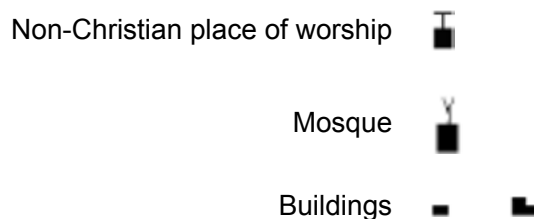

Figure 10 Black Conventional Signs

*Note.* Created by Director Cadets 3, 2008, Ottawa, ON: Department of National Defence.

**Brown.** Used for contour lines, contour elevations, spot elevations, sand, cliffs, and other geographical features.

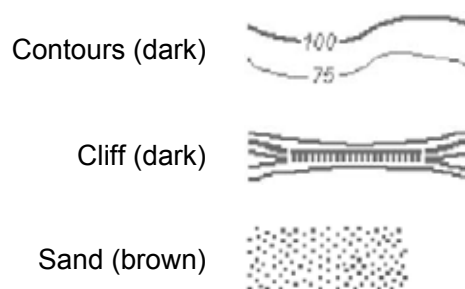

Figure 11 Brown Conventional Signs

*Note.* Created by Director Cadets 3, 2008, Ottawa, ON: Department of National Defence.

**Blue.** Used for water or permanent ice features (eg, rivers, lakes, swamps and ice fields), names of water features and the grid lines.

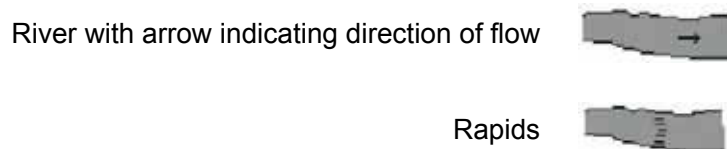

Figure 12 Blue Conventional Signs

*Note.* Created by Director Cadets 3, 2008, Ottawa, ON: Department of National Defence.

**Green.** Used for vegetation features such as woods, orchards and vineyards.

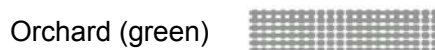

Figure 13 Green Conventional Signs

*Note.* Created by Director Cadets 3, 2008, Ottawa, ON: Department of National Defence.

**White.** Used to represent open fields.

**Grey.** Used for the legend of conventional signs on the back of the map.

**Purple.** Used for updates that are made over top of the original map information.

---

## ACTIVITY

Time: 10 min

### OBJECTIVE

The objective of this activity is to have the cadets locate marginal information and identify conventional signs on a topographical map.

### RESOURCES

- Topographical maps, and
- List of conventional signs (as per pre-lesson instructions).

### ACTIVITY LAYOUT

Large flat areas, preferably tables. If outside, use paperweights to hold down the maps.

### ACTIVITY INSTRUCTIONS

1. Review the purpose of marginal information.
2. Review the purpose of conventional signs.
3. Have the cadets study the topographical maps.
4. Have the cadets locate the following marginal information:
  - a. declination diagram,
  - b. date of map data,
  - c. scale bars,
  - d. map name, and
  - e. contour interval.
5. Have the cadets locate conventional signs.

### SAFETY

Nil.

---

### CONFIRMATION OF TEACHING POINT 2

The cadets' participation in the activity will serve as the confirmation of this TP.



Send the group to their next learning station (only for the first three groups). If this is the last group, have them rendezvous at the designated location for TP 6.

---

**Teaching Point 3****Conduct an activity to have the cadets review GRs.**

Time: 20 min

Method: Practical Activity

---

---

**BACKGROUND KNOWLEDGE**

---

**FOUR-FIGURE GRs**

Characteristics of a four-figure GR:

- Four-figure GRs will have four numerical digits derived from the numbers assigned to the eastings and northings on the map sheet.
- The numbers are listed by recording the two-digit easting followed by the two-digit northing.



The grid lines that intersect in the bottom left corner of the grid square are used to identify that grid square.

Steps to determine a four-figure GR:

1. Confirm the correct grid square.
2. Place a finger at the bottom left corner of the map.
3. Move that finger along the bottom of the map (left to right) up to the grid line (easting) before the grid square.
4. Record the two-digit easting.
5. Place a finger at the bottom left corner of the map.
6. Move that finger along the left side of the map (bottom to top) up to the grid line (northing) before the grid square.
7. Record the two-digit northing after the two-digit easting to create the four-figure GR.
8. Confirm the four-figure GR.

In Figure 14 Building A is located at GR 7433 and Building B at GR 7632.

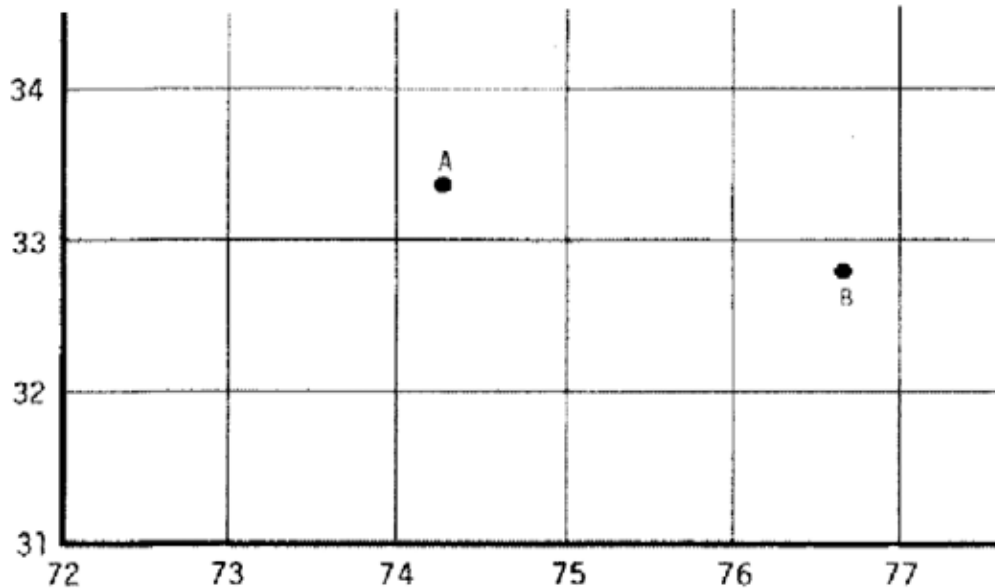

Figure 14 Four-Figure Grid References

*Note.* From *Maps, Field Sketching, Compasses and the Global Positioning System* (p. 37), Directorate of Army Doctrine 8, 2006, Ottawa, ON: Department of National Defence.

Steps to determine a grid square using a four-figure GR:

1. Confirm the four-figure GR.
2. Place a right-hand finger at the bottom left corner of the map.
3. Move that finger along the bottom of the map (left to right) up to the grid line (easting) numbered the same as the first two digits of the four-figure GR.
4. Place a left-hand finger at the bottom left corner of the map.
5. Move that finger along the left side of the map (bottom to top) up to the grid line (northing) numbered the same as the last two digits of the four-figure GR.
6. Move the right-hand finger up the grid line and the left-hand finger right along the grid line.
7. Where the two grid lines intersect is the bottom left corner of the grid square.
8. Confirm the correct grid square.

In Figure 14, GR 7532 represents the grid square southeast of Building A and west of Building B.

### CONSTRUCTING A ROMER

**Romer.** A device used for measuring a point within a grid square to determine its six-figure GR.

Romers may be purchased or created. Purchased romers include compasses and protractors. Constructed romers use a small piece of paper and the scale bars of a topographical map.



## Compass

Many compasses include romers already printed on the compass base plate. There are commonly two romers, for use with 1 : 25 000 and 1 : 50 000 scale topographical maps.

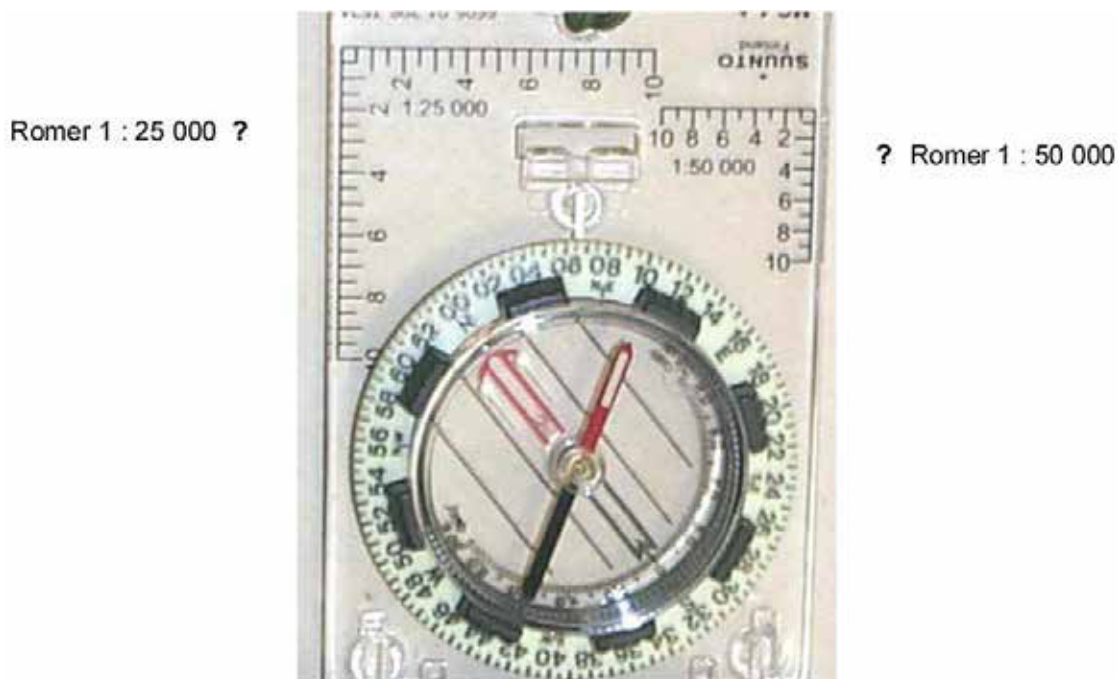

Figure 15 Compass

*Note.* Created by Director Cadets 3, 2008, Ottawa, ON: Department of National Defence.

**Protractor**

All protractors may be used to determine a bearing on a map, however, few have romers already printed on them. The Canadian Forces has created the C2 protractor (as illustrated in Figure 16) specifically designed for use on topographical maps.

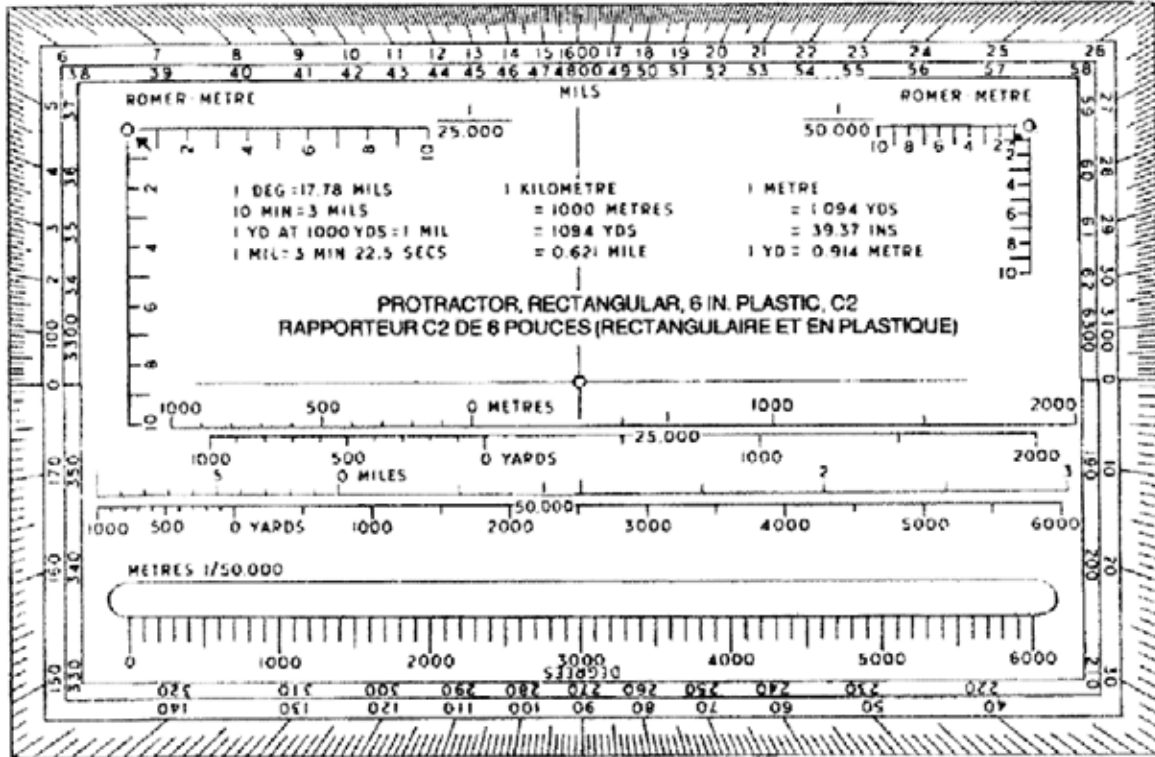

Figure 16 C2 Protractor

*Note.* From *Maps, Field Sketching, Compasses and the Global Positioning System* (p. 41), Directorate of Army Doctrine 8, 2006, Ottawa, ON: Department of National Defence.

## Constructed

A constructed romer requires a piece of paper with at least one square corner and the scale bars of the topographical map. Using the scale bars of the topographical map, a romer can be constructed as illustrated in Figure 17.

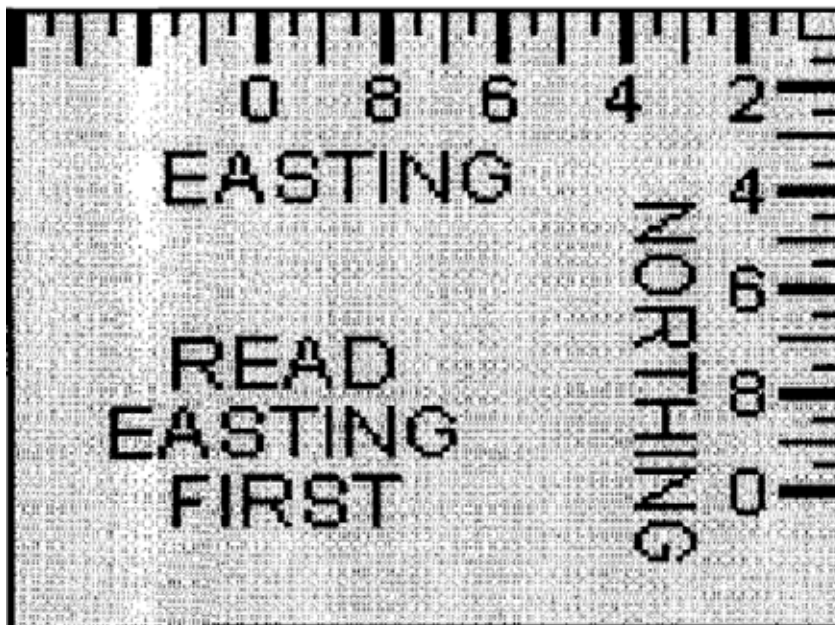

Figure 17 Constructed Romer

*Note.* From *Maps, Field Sketching, Compasses and the Global Positioning System* (p. 41), Directorate of Army Doctrine 8, 2006, Ottawa, ON: Department of National Defence.

Construct a romer for determining six-figure GRs by:

1. obtaining a blank piece of paper with a square edge;
2. placing one side of the square edge along the 100-m scale bars;
3. marking off 100-m segments beginning at the corner of the paper and working outward;
4. numbering these markings from zero (at the corner of the paper) to ten; and
5. repeating Steps 2–4 on the adjacent edge (eg, completed romer as illustrated in Figure 17).



It is important to use the correct scale bar. The constructed romer's markings should match the grid lines of the topographical map; the side of a grid square must be equal to ten 100-m marks on each of the romer's two edges.

## SIX-FIGURE GRs

Determine a six-figure GR using a constructed romer by:

1. placing the corner of the constructed romer on the bottom left corner of the grid square, noting the four-figure GR;
2. moving the constructed romer to the right the number of tenths required to align the romer directly to or before (never past) the conventional sign or location for which the GR is being determined;

3. reading the value along the X-axis of the romer where it crosses the easting on the map sheet (the value at this intersection becomes the value for the third digit of the six-figure GR);
4. moving the constructed romer up the number of tenths required for the corner of the romer to be positioned on or before (never past) the conventional sign or location for which the GR is being determined;
5. reading the value along the Y-axis of the romer where it crosses the northing on the map sheet (the value at this intersection becomes the value for the sixth digit of the six-figure GR); and
6. combining the two sets of digits to create the six-figure GR.



Figure 18 Using a Constructed Romer

*Note.* From *Royal Canadian Army Cadet Reference Book* (p. 5-20), by Director Cadets 3, 2003, Ottawa, ON: Department of National Defence.

Determine what a six-figure GR represents using a constructed romer, by:

1. determining the four-figure GR, by removing the third and sixth digits from the six-figure GR, to identify and locate the correct grid square;
2. placing the corner of the constructed romer on the bottom left corner of the grid square;
3. moving the constructed romer to the right the number of tenths, as identified by the third digit;
4. moving the constructed romer up the number of tenths, as identified by the sixth digit; and
5. determining the object (that is up and to the right from the tip of the romer).

---

### ACTIVITY

Time: 20 min

### OBJECTIVE

The objective of this activity is to have the cadets determine four- and six-figure GRs and construct a romer.

### RESOURCES

- Topographical maps,
- List of 20 conventional signs (as per pre-lesson instructions),
- Pens / pencils, and
- Paper.

**ACTIVITY LAYOUT**

Large flat areas, preferably tables. If outside, use paperweights to hold down the maps.

**ACTIVITY INSTRUCTIONS**

1. Have the cadets study the topographical maps.
2. Have the cadets determine the four-figure GR for each conventional sign.
3. Have the cadets determine the conventional sign of each four-figure GR.
4. Have the cadets construct a romer.
5. Have the cadets determine a six-figure GR for each grid square.
6. Have the cadets determine the conventional sign of each six-figure GR.

**SAFETY**

Nil.

**CONFIRMATION OF TEACHING POINT 3**

The cadets' participation in the activity will serve as the confirmation of this TP.



Send the group to their next learning station (only for the first three groups). If this is the last group, have them rendezvous at the designated location for TP 6.

**Teaching Point 4**

**Conduct an activity to have the cadets review determining distance on a map and determining bearings on a map.**

Time: 20 min

Method: Practical Activity

**BACKGROUND KNOWLEDGE****DETERMINING DISTANCE ON A MAP**

Cadets can use a map to measure the distance between two points (eg, points A and B as illustrated at Figure 19) on the ground. All maps are drawn to scale; therefore, a specified distance on a map equals a specified distance on the ground. The scale of a map is printed at the top and bottom of each map (eg, scale 1 : 50 000). This means that 1 cm on the map equals 50 000 cm (500 m) on the ground.

There are two ways to determine distance on a topographical map—point-to-point and along-a-route.

## Measuring Point-to-Point

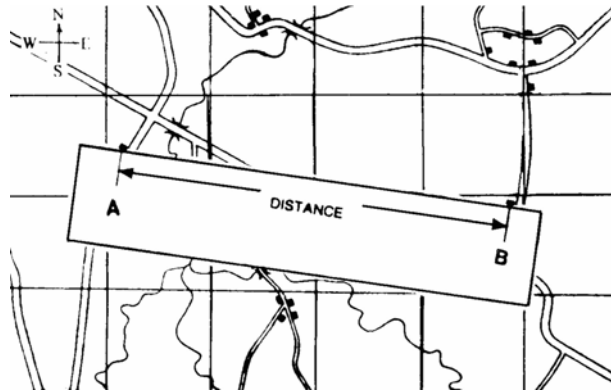

Figure 19 Measure Distance Point-to-Point

*Note. From Royal Canadian Army Cadet Reference Book (p. 5-24), by Director Cadets 3, 2003, Ottawa, ON: Department of National Defence.*

To measure a distance point-to-point:

1. Lay the straight edge of a piece of paper against the two points.
2. With a sharp pencil, mark the paper at the A (start) and B (end) points.
3. Lay the paper just under the metres scale bar with the B mark at the right end of the scale. Move the paper to the left, aligning the B mark with each thousand metre mark until the A mark falls within the subdivided thousands (hundreds) to the left of the zero.
4. To calculate the total distance, add the number of thousands where the B mark is, plus the number of subdivided thousands where the A mark is to the left of the zero.

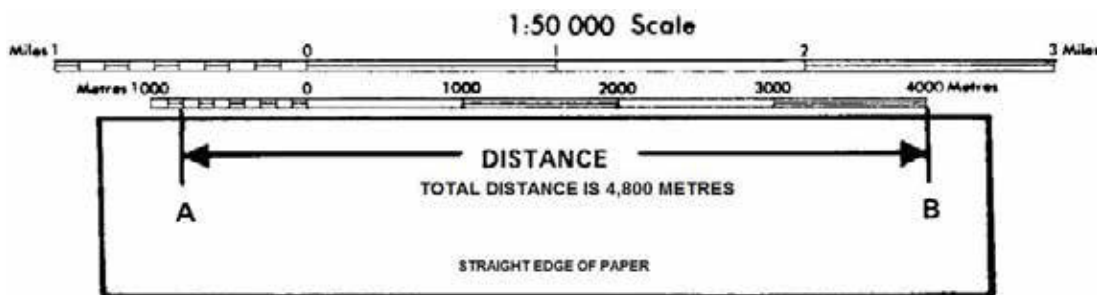

Figure 20 Calculate Distance

*Note. From Royal Canadian Army Cadet Reference Book (p. 5-25), by Director Cadets 3, 2003, Ottawa, ON: Department of National Defence.*



For a distance that is longer than 5 000 m, measure the first 5 000 m and mark the paper with a new line and label it '5 000 m'. Place the new mark at the zero or thousands mark until the A mark fits within the subdivided thousands (hundreds) bar. Add the total of that distance to the 5 000 m to create the total distance.

### Measuring Along-a-Route Between Two Points

Sometimes cadets need to find the distance between A and B around the curves in a road along a planned route.

To measure a distance along a route between two points:

1. Lay the straight edge of a piece of paper against point A.
2. With a sharp pencil, mark point A on the paper and the map.
3. Line up the paper with the edge of the road until a curve is reached and make another mark on the paper and on the map.
4. Pivot the paper so that it continues to follow the road edge. Repeat until point B is reached.
5. Mark the paper and the map at point B.
6. Lay the paper just under the metres scale bar with the B mark at the right end of the scale. Move the paper to the left, aligning the B mark with each thousand metre mark until the A mark falls within the subdivided thousands (hundreds) to the left of the zero.
7. Add the number of thousands where the B mark is, plus the number of subdivided thousands (hundreds) where the A mark is to the left of the zero, to determine the total distance.

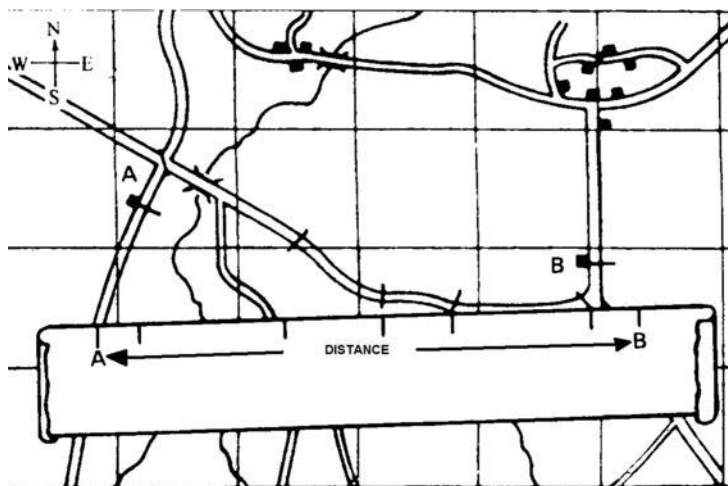

Figure 21 Measure Distance Along-a-Route

*Note.* From *Royal Canadian Army Cadet Reference Book* (p. 5-25), by Director Cadets 3, 2003, Ottawa, ON: Department of National Defence.

### DETERMINING BEARINGS ON A MAP

In order to determine bearings on a map, the cadet needs to understand the points of a compass, the degree system, the three norths and types of bearings.

## The 16 Points of a Compass



Figure 22 Compass Rose

*Note.* Created by Director Cadets 3, 2007, Ottawa, ON: Department of National Defence.

The four cardinal points of the compass, measured at right angles clockwise from north are:

- north (N) at 0 and 360 degrees,
- east (E) at 90 degrees,
- south (S) at 180 degrees, and
- west (W) at 270 degrees.

The four inter-cardinal points are located halfway between each of the cardinal points. Measured clockwise from north, they are:

- northeast (NE) at 45 degrees,
- southeast (SE) at 135 degrees,
- southwest (SW) at 225 degrees, and
- northwest (NW) at 315 degrees.

The eight intermediate points are located halfway between each cardinal point and inter-cardinal point. Measured clockwise from north, they are:

- north-northeast (NNE) at 22.5 degrees,
- east-northeast (ENE) at 67.5 degrees,
- east-southeast (ESE) at 112.5 degrees,
- south-southeast (SSE) at 157.5 degrees,



- south-southwest (SSW) at 202.5 degrees,
- west-southwest (WSW) at 247.5 degrees,
- west-northwest (WNW) at 292.5 degrees, and
- north-northwest (NNW) at 237.5 degrees.



As an aid to remember the different types of points:

- cardinal points are designated by one letter,
- inter-cardinal points are designated by two letters, and
- intermediate points are designated by three letters.

### The Degree System

The cardinal, inter-cardinal, and intermediate points describe directions only to within one-sixteenth of a full circle. For a more precise indication of direction, it is necessary to use the sub-divisions of the circle called degrees. This measurement starts and ends at north (top) and is measured in a clockwise rotation.

**Degrees.** The most common method of dividing a circle is by degrees. These degrees represent 360 equal angles in a complete circle and they are represented by the symbol "°" (eg, 222°).



It is important to emphasize that degrees should always be measured clockwise and always using north as the start point.

### The Three Norths

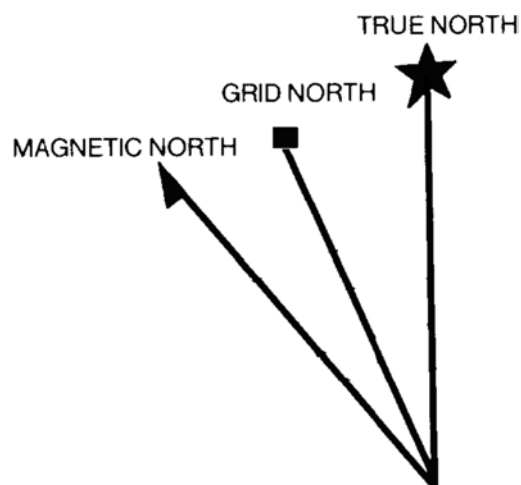

Figure 23 The Three Norths

*Note.* Created by Director Cadets 3, 2008, Ottawa, ON: Department of National Defence.

The relationship between the three norths, especially grid and magnetic, is key to using a compass on both a map and on the ground.

**True north.** True north is located at the top of the earth where the geographic North Pole is located, where all lines of longitude meet. In the declination diagram on the map, true north is represented by the symbol of a star, which represents the North Star, Polaris.

**Grid north.** Grid north is the north indicated by the grid lines (eastings) on a topographical map. The easting lines run parallel to each other and will never meet at the geographic North Pole; because of this, grid north points off slightly from true north. In the declination diagram on the map, grid north is represented by a square, which represents a map grid.

**Magnetic north.** Magnetic north is the location of the north magnetic pole, where the Earth's magnetic field bends back into the Earth toward the south magnetic pole. It is located in the Canadian arctic and is different from true north. It is the direction in which the compass needle points. In the declination diagram on the map, magnetic north is represented by a needle as on a compass.

The differences between the three norths affect navigation for the map and compass user, in the form of magnetic declination. Magnetic declination is the difference in bearing either between true north and magnetic north or between grid north and magnetic north.



Cadets will normally use the magnetic declination value between grid north and magnetic north when navigating using a map and compass. By setting the magnetic declination on the compass, magnetic bearings are converted to grid bearings which allow bearings taken from the map to be used on the ground and vice versa.

### Types of Bearings

**Bearing.** A bearing is an angle that is measured clockwise, from north. It is measured in degrees and is relative to the observer.



In geometry, an angle is based on three points; a vertex, and two points, each of which designates a ray. For a bearing, the vertex is the point where the bearing is taken from, another point is north, and the last point is where the bearing is directed to. The north (either true, grid or magnetic) used identifies the type of bearing.

In ground navigation, one ray of the angle points north (usually grid north) and the other ray, known as a plotting ray, points to the object / direction.

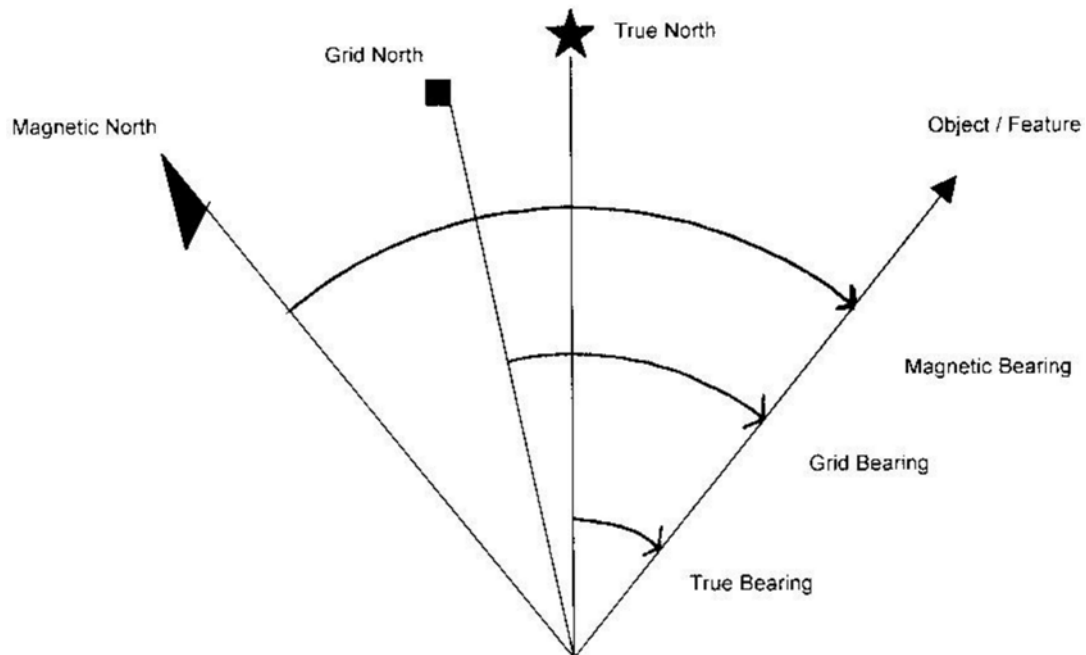

Figure 24 Types of Bearings

Note. Created by Director Cadets 3, 2008, Ottawa, ON: Department of National Defence.

**True bearings.** A true bearing is a bearing measured from true north. While map users rarely use them, directions determined using the sun, moon and stars are true bearings. Global Positioning System (GPS) receivers also use true bearings.

**Grid bearings.** A grid bearing is a bearing measured from grid north. The ability to determine a bearing from a map allows a map user to plan routes or activities before going into the field, and allows an easy method of communicating information about movement or location.

**Magnetic bearings.** A magnetic bearing is measured from magnetic north and is measured using a compass, which either has no option of setting magnetic declination or has the magnetic declination set to zero. A magnetic bearing is a quick and efficient method of describing a route when a map is not being used.



If a compass has its declination set to zero, bearings to objects on the ground determined by that compass are magnetic bearings. Setting the magnetic declination on a compass converts the magnetic bearings determined by that compass into grid bearings for the map being used.

**Back bearing.** A back bearing is a bearing that is in exactly the opposite direction of the bearing that has been measured. A back bearing can be useful for different reasons: to return to the start location after a hike, or to calculate the bearing from an object to one's current location. The steps to calculate a back bearing are:

- if the bearing is less than 180 degrees, add 180 degrees; and
- if the bearing is greater than 180 degrees, subtract 180 degrees.

---

## ACTIVITY

Time: 20 min

### OBJECTIVE

The objective of this activity is to have the cadets determine distances and bearings on a map.

### RESOURCES

- Topographical maps,
- Sets of GRs for distances (as per pre-lesson instructions),
- Sets of GRs for bearings (as per pre-lesson instructions),
- Pens / pencils, and
- Paper.

### ACTIVITY LAYOUT

Large flat areas, preferably tables. If outside, use paperweights to hold down the maps.

### ACTIVITY INSTRUCTIONS

1. Have the cadets study the topographical maps.
2. Have the cadets determine the distance point-to-point on a map.
3. Have the cadets determine the distance along-a-route on a map.
4. Have the cadets identify the 16 points of a compass.
5. Have the cadets describe the degree system.
6. Have the cadets identify the three norths.
7. Have the cadets describe types of bearings.
8. Have the cadets determine a bearing on a map (as per created list).

### SAFETY

Nil.

---

### CONFIRMATION OF TEACHING POINT 4

The cadets' participation in the activity will serve as the confirmation of this TP.



Send the group to their next learning station (only for the first three groups). If this is the last group, have them rendezvous at the designated location for TP 6.

**Teaching Point 5**

**Conduct an activity to have the cadets review determining distance on the ground and determining bearings on the ground.**

Time: 20 min

Method: Practical Activity

---

**BACKGROUND KNOWLEDGE**

---

**DETERMINING DISTANCE ON THE GROUND**

Before distance can be determined on the ground, a method of measuring distance needs to be found. One such method is by determining one's own personal pace.

**Determining a Personal Pace for 100 m**

Being able to determine distance is a key skill for ground navigation. By learning how to determine distance using a personal pace, a cadet will have the skill to determine how far they have travelled, and how far they have to travel to reach their destination.

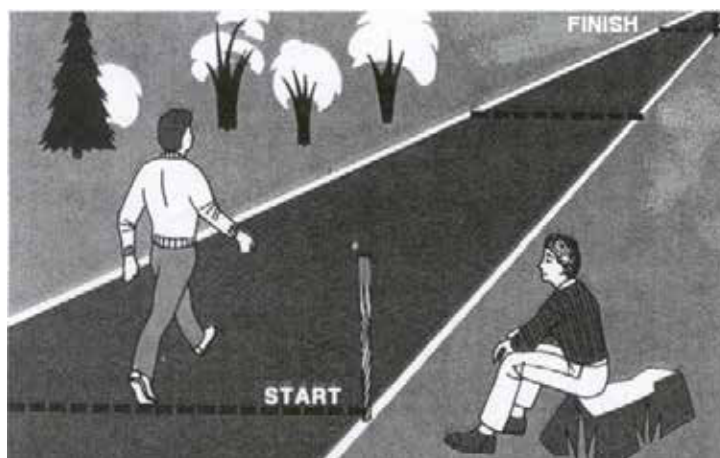

Figure 25 Determining Distance Using Pacing

*Note.* From *Be Expert With Map & Compass* (p. 53), by B. Kjellstrom, 1994, New York: Hungry Minds, Inc. Copyright 1994 by Bjorn Kjellstrom.

**Personal pace.** The number of paces a person walks over a distance of 100 m.

**Counting Paces**

There are two basic methods to count pace:

- count every pace (count every step); or
- count every other pace (count every left or every right step).

For example:

- count every pace: 140 paces = 100 m; or
- count every other pace: 70 paces = 100 m.

## Calculating Distance

In order to determine distance travelled, the total number of paces travelled is divided by the personal pace and multiplied by 100 m to calculate the number of metres travelled.

Formula:

$$\frac{\text{total number of paces}}{\text{personal pace}} \times 100 \text{ m} = \text{total distance travelled (m)}$$

Example:

$$\frac{140 \text{ paces}}{70} \times 100 \text{ m} = 200 \text{ m}$$

Common methods of keeping track of the number of paces travelled include:

- transferring pebbles from one pocket to another: one pebble for each 100 paces;
- using a length of cord with knots—the knotted cord is held with the hand gripping a knot and the hand is advanced one knot down the cord for every 100 paces; and
- combining the knotted cord and pebbles (eg, cord with 10 knots, pebbles transferred for each completed cord [10 knots x 100 paces each = 1000 paces / pebble]).

## Identifying Factors That Affect Pace

Factors that will affect personal pace include:

**Terrain.** The rougher the ground, the shorter the pace.

**Slopes.** Pace is shorter going uphill and longer going downhill.

**Fatigue.** Will shorten a person's pace.

**Equipment.** Footwear with poor traction will shorten a person's pace. Carrying a heavy load will also shorten a person's pace.

**Weather.** Snow and rain will shorten a person's pace. The wind will increase / decrease pace length if a person is travelling with / against the wind.

**Obstacles.** Going around small features (eg, trees, bushes) will affect pace count unless compensated for. Compensation methods include:

- **Sidestepping.** Stepping to the side (left / right) enough paces to bypass the obstacle, pacing forward past the obstacle and sidestepping back (right / left) to return to the original line of travel. This method maintains pace accuracy, but takes time.

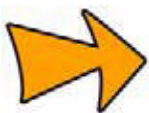

The paces that the cadets sidestep are not added to their total pace count.

- **Alternating sides.** In this method, the cadet alternates which side (left / right) of the obstacle they pass (eg, last obstacle was passed on the left, next will be on the right). This method is less accurate, but faster.



If obstacles are always bypassed on the same side, the line of travel will veer off in that direction unless a distant steering point (eg, tall tree, hill top, building) is used as a guide.

### DETERMINING BEARINGS ON THE GROUND

A compass can be used to determine the bearing for a direction of travel and from one's current location to a prominent object. The ability to take a bearing of a prominent object also allows the cadet to look for a prominent object as a steering point when they need to follow a given bearing. A bearing is a quick and accurate method for describing the direction of travel.



A prominent object is something that is usually tall and easily recognizable (eg, church steeple, tall tree or hilltop).



Figure 26 Determining a Bearing

*Note.* Created by Director Cadets 3, 2008, Ottawa, ON: Department of National Defence.



After the cadets have demonstrated the skill, have them practice determining the bearings of other prominent objects. This location should be predetermined by the recce IAW the pre-lesson instructions.

To determine the bearing of a prominent object:

1. Set the predetermined declination on the compass.
2. Hold the compass at eye level and at arm's length, and turn to face the prominent object (as illustrated in Figure 26).
3. Aim at the object using the compass sight, ensuring the sighting line is in line with the index pointer.
4. Adjust the compass cover so the compass dial is seen in the sighting mirror.

5. Look in the mirror and turn the compass dial until the magnetic needle is over the orienting arrow (put the red in the bed).
6. Read the number on the compass dial at the luminous index pointer.



Inform the cadets that when taking a bearing of a prominent object they will get different readings than other cadets unless they are all using the same line of sight to that prominent object (eg, standing in the same spot).

---

## ACTIVITY

Time: 20 min

### OBJECTIVE

The objective of this activity is to have the cadets determine distance on the ground and to determine bearings on the ground.

### RESOURCES

- Compass, and
- Bearing course.

### ACTIVITY LAYOUT

Pace course set up as per pre-lesson instructions. A bearing course with locations identified (spot to take bearing from and the prominent object / feature for which to take the bearing).

### ACTIVITY INSTRUCTIONS

1. Have the cadets determine their personal pace using the pace course.
2. Have the cadets identify factors that affect pace.
3. Have the cadets determine bearings on the ground using the bearings course.

### SAFETY

Nil.

---

### CONFIRMATION OF TEACHING POINT 5

The cadets' participation in the activity will serve as the confirmation of this TP.



Send the group to their next learning station (only for the first three groups). If this is the last group, have them rendezvous at the designated location for TP 6.



---

**Teaching Point 6****Have the cadets navigate a route using a map and compass.**

Time: 30 min

Method: Practical Activity

---

**ACTIVITY****OBJECTIVE**

The objective of this activity is to have the cadets navigate a route using a map and compass.

**RESOURCES**

- Topographical map of the area,
- Predetermined magnetic declination,
- Set of four 6-figure GRs (the start point and the endpoint of each leg),
- Compass,
- Pencil, and
- Paper.

**ACTIVITY LAYOUT**

Four to six 3-leg map and compass courses, with the starting point for each course designated with a stake / marker.

**ACTIVITY INSTRUCTIONS**

1. Divide the cadets into groups of two.
2. Distribute a map, a compass, the predetermined magnetic declination, safety bearing, a set of four 6-figure GRs, a pencil and a sheet of paper to each group.
3. Brief the cadets on the activity, to include:
  - a. the purpose of the activity, and
  - b. safety.
4. Move the cadets to their start points.
5. Have the cadets complete their navigation exercise.
6. Have the cadets return their maps and compasses.

**SAFETY**

Nil.

---

**CONFIRMATION OF TEACHING POINT 6**

The cadets' participation in the activity will serve as the confirmation of this TP.

---

## END OF LESSON CONFIRMATION

The cadets' navigating a route using a map and compass will serve as the confirmation of this lesson.

---

## CONCLUSION

---

## HOMEWORK / READING / PRACTICE

Nil.

## METHOD OF EVALUATION

Nil.

## CLOSING STATEMENT

Map and compass skills are important when training in a field setting. It allows groups to navigate within the training area in a safe manner. Survival training usually requires working within the bush away from the main exercise site. Understanding and practicing these skills allows the cadets to help plan survival training and organize routes between the main exercise site and the aircrew survival training areas.

## INSTRUCTOR NOTES / REMARKS

TPs 1–5 are taught by learning stations. Divide the cadets into four groups and have the groups rotate between four learning stations: one station for TPs 1 and 2 and one station each for TPs 3–5.

To preserve and reuse the maps, they should be covered or coated with mac tac to allow the use of dry-erase markers instead of pencils or pens.

Assistant instructors and cadets who are qualified Survival Instructor may assist with this instruction.

---

## REFERENCES

---

A2-036 A-CR-CCP-121/PT-001 Director Cadets 3. (2003). *Royal Canadian Army Cadet reference book*. Ottawa, ON: Department of National Defence.

A2-041 B-GL-382-005/PT-001 Directorate of Army Doctrine 8. (2006). *Maps, field sketching, compasses and the global positioning system*. Ottawa, ON: Department of National Defence.

C0-111 ISBN 978-0-9740820-2-8 Tawrell, P. (2006). *Camping and wilderness survival: The ultimate outdoors book* (2nd ed.). Lebanon, NH: Author.

C2-041 ISBN 978-0-07-1361101-3 Seidman, D., & Cleveland, P. (1995). *The essential wilderness navigator*. Camden, ME: Ragged Mountain Press.



**ROYAL CANADIAN AIR CADETS**  
**PROFICIENCY LEVEL FOUR**  
**INSTRUCTIONAL GUIDE**



**SECTION 11**

**EO C490.06 – ERECT, TEAR DOWN AND PACK TENTS**

---

Total Time:	120 min
-------------	---------

---

**PREPARATION**

---

**PRE-LESSON INSTRUCTIONS**

Resources needed for the delivery of this lesson are listed in the lesson specification located in A-CR-CCP-804/PG-001, *Proficiency Level Four Qualification Standard and Plan*, Chapter 4. Specific uses for said resources are identified throughout the instructional guide within the TP for which they are required.

Review the lesson content and become familiar with the material prior to delivering the lesson.

Additional instructors are required for this lesson to ensure TP 1 is covered in the time allotted.

**PRE-LESSON ASSIGNMENT**

Nil.

**APPROACH**

An interactive lecture was chosen for TP 1 to give direction on factors to consider when selecting a site.

A demonstration and performance was chosen for TPs 2 and 3 as it allows the instructor to explain and demonstrate erecting, tearing down and packing tents while providing an opportunity for the cadets to practice the skills under supervision.

---

**INTRODUCTION**

---

**REVIEW**

Nil.

**OBJECTIVES**

By the end of this lesson the cadet shall have the opportunity to erect, tear down and pack a two-section modular tent with walls and either an arctic tent or a civilian-pattern tent.

**IMPORTANCE**

It is important for the cadets to be able to use a modular tent because they are often used during aircrew survival exercises. A cadet's understanding of this lesson will allow them to better assist in the set-up of an aircrew survival exercise.

---

**Teaching Point 1**

**Discuss site selection.**

Time: 10 min

Method: Interactive Lecture

---

**SITE SELECTION**

When selecting a tent site on snow-covered ground, choose an area free from crevices. Prod the surface to ensure that a flat base is selected. The snow shall be removed until a firm base is exposed. The tent shall, if possible, be positioned so that its side is located downwind to avoid drifting snow blocking the entranceway.

When setting up an exercise site, it is important to know where to locate your sites for tents. There are factors to consider when doing this and they should be followed correctly as it is beneficial to everyone. The factors to consider are:

- Vehicle access for set-up and equipment transport.
- Inspecting the area for proximity to a water source that provides potable water and food from fishing.
- Inspecting for proximity to a fuel source for fire during cold weather.
- Inspecting for proximity to building materials.
- Inspecting proximity to animal trails and holes.
- Inspecting an entrance that is sheltered from the wind and preferably in the direction of the sun.
- Placing the tents away from the cooking area.

---

**ACTIVITY**

Time: 5 min

**OBJECTIVE**

The objective of this activity is to have the cadets find a site that is suitable for setting up tents.

**RESOURCES**

Nil.

**ACTIVITY LAYOUT**

Nil.

**ACTIVITY INSTRUCTIONS**

Have cadets, in pairs, find suitable sites for setting up tents.

---

**CONFIRMATION OF TEACHING POINT 1**

The cadets' participation in the activity will serve as the confirmation of this TP.

**Teaching Point 2**

**Explain, demonstrate and have the cadets, as a member of a group, erect, tear down and pack a two-section modular tent with walls.**

Time: 70 min

Method: Demonstration and Performance



For this skill, it is recommended that the instruction take the following format:

1. Explain and demonstrate each step in erecting, tearing down and packing a modular tent.
2. After demonstrating each step have the cadets perform the skill while monitoring their performance.

Note: Assistant instructors may be employed to monitor the cadets' performance.



If the modular tent is going to remain erected for the duration of the exercise, instruct tearing down and packing at the end of the exercise.

**COMPONENTS OF A MODULAR TENT**

A module of tent is comprised of a canvas section supported by tubular aluminum framework. It measures 2.5 m long by 5.5 m wide. The frame of a modular tent consists of two arch frames and three purlins (the horizontal beams along the length of the roof that support the canvas). The arch frame is hinged at the peak and the eaves. When folded the arch measures 2.75 m long. The purlins are 2.5 m long and connect two arches; one purlin at the peak and two more at each eave. They are locked into place without the use of tools. The framework is anchored with steel pegs which are inserted at the base of each arch and can be diagonally cross braced with cables or straps, between the eaves and base of the arches, to give an unobstructed inside space and an outside perimeter clear of guy wires. Guy wires are only used when the tent requires further reinforcement.

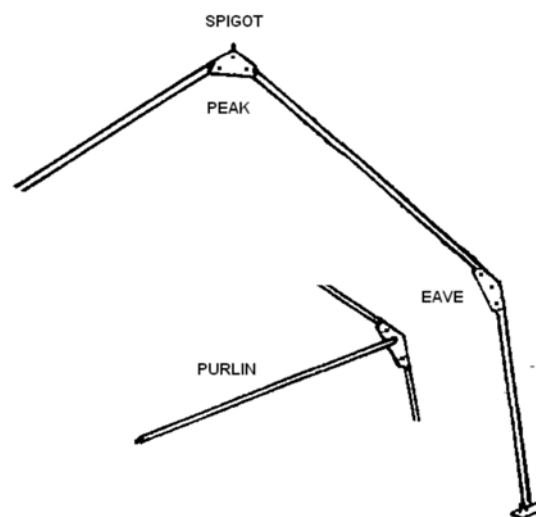

Figure 1 Frame

Note. Created by Director Cadets 3, 2007, Ottawa, ON: Department of National Defence.

## TENT SECTIONS

The three tent sections are centre sections, front walls and rear walls. The tent sections attach to one another by means of a series of cord loops and grommets known as "Dutch lacing". The cord loops are on the opposite side of the grommets requiring all sections to be placed in the same direction. For example, all the cord loops on the right. Tent sections are made of olive green, core-spun, polyester-cotton, rip-stop woven material treated to be water-, rot- and flame-resistant. The sod cloth which extends 40 cm from the foot of each tent section is made from plastic-coated, waterproof material. The windows are screened and have blackout flaps and transparent vinyl panels which are attached with fastener tape (Velcro).

**Centre section.** This is the canvas roof and side wall covering of a module. It has a window in each side and a chimney opening in the roof.

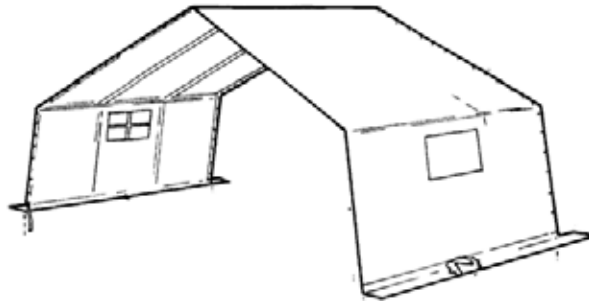

Figure 2 Centre Section

*Note.* From C-87-110-000/MS-000 *Operational Support and Maintenance Manual for Tent, Main*(p. 1-5), by DND Canada, 1983, Ottawa ON: Department of National Defence. Copyright 1983 by DND Canada.

**Front wall.** Attaches with grommets and opens with two zippered personnel doors. The front wall includes one window and a closable air vent.

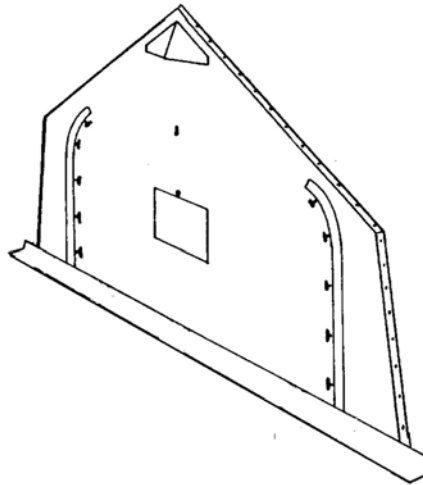

Figure 3 Front Wall

*Note.* From C-87-110-000/MS-000 *Operational Support and Maintenance Manual for Tent, Main*(p. 1-5), by DND Canada, 1983, Ottawa ON: Department of National Defence. Copyright 1983 by DND Canada.

**Rear wall.** Attaches with cord loops and opens in the centre. The opening reaches the peak of the module and is fastened with toggles, allowing access for large equipment. The rear wall includes two windows.

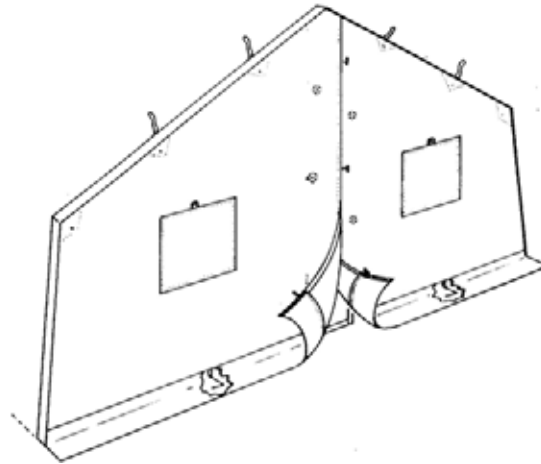

Figure 4 Rear Wall

*Note.* From C-87-110-000/MS-000 *Operational Support and Maintenance Manual for Tent, Main*(p. 1-5), by DND Canada, 1983, Ottawa ON: Department of National Defence. Copyright 1983 by DND Canada.

## ACCESSORIES

**Liners.** The three common tent sections—centre section, front wall and rear wall—each have corresponding white fabric liners. These provide insulation as well as a light reflective surface, and are made from flame resistant material. The liners are suspended from inside the frame and are laced together similar to the tent sections.

**Blackout hallway.** Black fabric enclosure, 2.5 m long, attached inside the tent and laced to a grommet by the doorway, to prevent the entranceway from emitting light.

**Lacing band.** Provides the cord loops, to tie the two tent sections together when the module lacing sequence is disrupted because two grommet ends meet. It is 8.5 m long and 15 cm wide. A strap and a hooked shock cord are at each end to secure it to the frame and keep the band taut against the canvas.

**Guy wires.** Lines of cord that assist in securing the tent to the ground. Available for situations where the footings cannot be anchored in the ground or where the tent is subject to extreme windy conditions.

**Bag tent.** This is a flat canvas wrap specifically designed for containing tent sections. It includes a pocket to hold pertinent hardware.

**Tools.** A mallet, shovel and occasionally a stepladder. Tools are not included.



Explain tent maintenance to the cadets, but do not demonstrate or have the cadets perform.

## TENT MAINTENANCE

The following precautionary measures, when followed, will protect the tent components from corrosion, mildew, rot and unnecessary damage and will work to prolong the life and usefulness of the tentage:

- Avoid folding or packing tent or liner sections when wet. Wet or damp tentage shall be unfolded and air dried within 48 hours.
- Protect tent and liner sections from petroleum and chemical stains. If soiling occurs, clean immediately with warm soapy water.
- Do not allow oil, mud or other foreign matter to gather or harden on frame components. Warm soapy water or cleaning solvents are recommended for cleaning. The components should not be lubricated.
- Do not leave collapsed tent sections and components in contact with the ground or exposed to the elements for more than 48 hours.
- All detected damage should be identified, reported and repaired at the earliest convenience.
- Dragging tentage on the ground, walking on tentage and general rough handling is prohibited.
- Effort shall be made to keep tentage equipment serviceable at all times and preventative maintenance practices must be employed during use.
- Erect and tear down tentage in accordance with the detailed procedures.



Explain, demonstrate and have the cadets perform each step in erecting, tearing down and packing.

## ERECTING

### Lay Out and Connect the Frame

Expand all arch frames leaving the legs in a folded position and space them in module increments using a purlin as a measure. Connect the purlins to each arch at the peak and eaves.

### Lock the Frame

To operate the connecting, locking device on the peak bracket, first ensure the lock is released by:

1. placing the button head pin of the purlin into the bracket keyhole and push it upward in the keyhole slot;
2. moving the sliding bar up to allow the pivot lock to be swung over to hold the purlin in place;
3. moving the sliding bar down to lock the pivot;
4. operating the save bracket lock by lifting the sliding bar; and
5. releasing the arch frame leg from its erected state and moving down the lever lock, located inside the eave bracket.



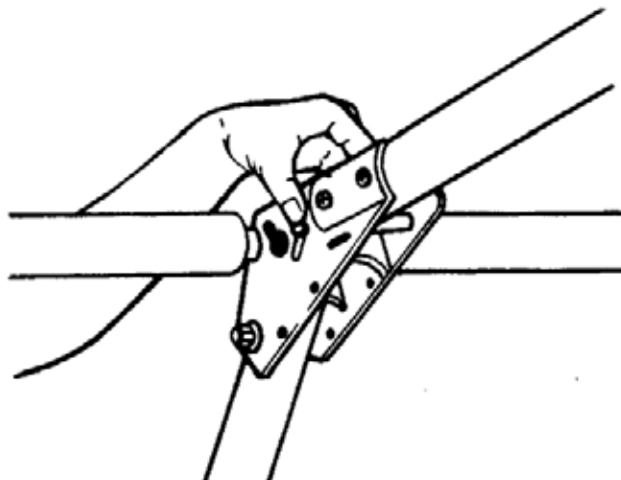

Figure 5 Frame Lock

*Note.* From C-87-110-000/MS-000 *Operational Support and Maintenance Manual for Tent, Main*(p. 2-5), by DND Canada, 1983, Ottawa ON: Department of National Defence. Copyright 1983 by DND Canada.

### Connect Tent Sections

Identify the tent sections and position them so the front-rear sequence of lacing corresponds to the front and rear wall location. Lace the centre sections together using the dutch lace as follows:

1. Sandwich the grommet side between the flaps on the lacing side.

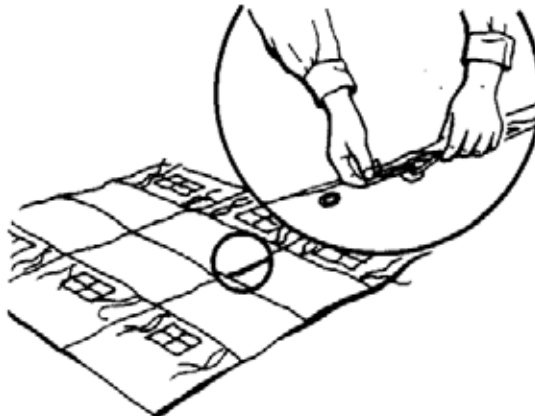

Figure 6 Canvas Lacing

*Note.* From C-87-110-000/MS-000 *Operational Support and Maintenance Manual for Tent, Main*(p. 2-8), by DND Canada, 1983, Ottawa ON: Department of National Defence. Copyright 1983 by DND Canada.

2. Pass the cord loops through the corresponding grommet holes and then through the next loop working from the centre outwards.

3. Tie off the last loop.

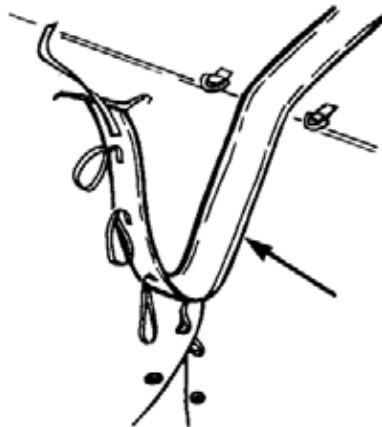

Figure 7 Canvas Lacing

*Note.* From C-87-110-000/MS-000 *Operational Support and Maintenance Manual for Tent, Main*(p. 1-8), by DND Canada, 1983, Ottawa ON: Department of National Defence. Copyright 1983 by DND Canada.

### **Raise the Side and Place Canvas**

The following steps outline the procedure for raising the modular tent structure and placing the canvas:

1. Ensure the doors on the front and rear walls are closed. If the doors are left open they will be difficult to close after the modular tent is erected.
2. Raise one side of the frame with one person assigned to each arch frame. In windy conditions, temporarily secure the upright section to the ground with the tent pegs.



Figure 8 Erect One Side

*Note.* From C-87-110-000/MS-000 *Operational Support and Maintenance Manual for Tent, Main*(p. 2-8), by DND Canada, 1983, Ottawa ON: Department of National Defence. Copyright 1983 by DND Canada.

3. Place the previously folded canvas on the sloped side of the frame, positioning the master grommets (large holes at the peak of the canvas) over the frame spigots (large point at the peak of the frame), and then unfold the canvas onto the raised side.



Figure 9 Place Canvas

*Note.* From C-87-110-000/MS-000 *Operational Support and Maintenance Manual for Tent, Main*(p. 2-8), by DND Canada, 1983, Ottawa ON: Department of National Defence. Copyright 1983 by DND Canada.

4. Secure eave and foot straps on the raised side.
5. Attach the front and rear walls to the centre sections along the roof line only.
6. Raise the other side of the tent and align legs.
7. Attach save straps (straps on the underside of the canvas that attach to the purlins as illustrated in Figure 10) and bracing cables (support cables as illustrated in Figure 11) but do not tighten.

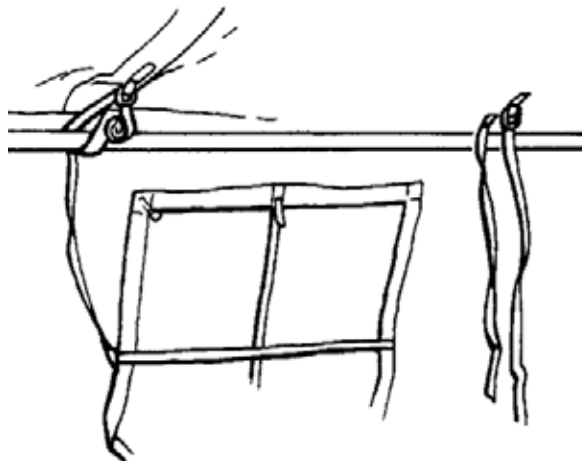

Figure 10 Save Straps

*Note.* From C-87-110-000/MS-000 *Operational Support and Maintenance Manual for Tent, Main*(p. 2-8), by DND Canada, 1983, Ottawa ON: Department of National Defence. Copyright 1983 by DND Canada.

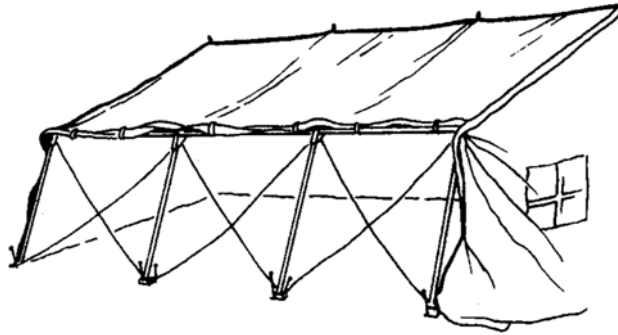

Figure 11 Bracing Cables

*Note.* From C-87-110-000/MS-000 *Operational Support and Maintenance Manual for Tent, Main*(p. 2-8), by DND Canada, 1983, Ottawa ON: Department of National Defence. Copyright 1983 by DND Canada.

8. Complete lacing the end walls to the centre sections.
9. Raise the other side and adjust the positioning and alignment of the arch legs to achieve a smooth canvas fit.

### Anchor

The following steps outline the procedure for anchoring the modular tent to the ground:

1. Secure the frame to the ground. Hammer in the steel pegs (two per foot), working from the outside of the tent, so that the pegs are angled inwards (to prevent frame lifting as illustrated in Figure 12).

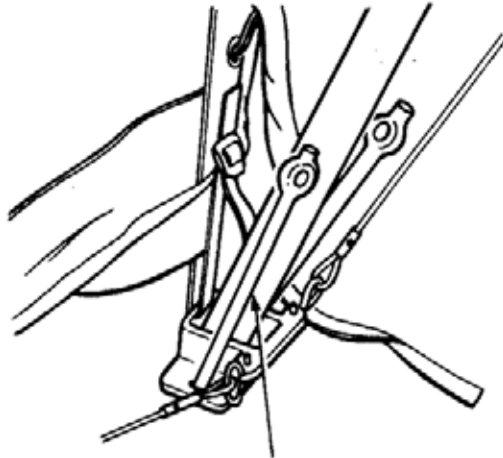

Figure 12 Drive in Pegs

*Note.* From C-87-110-000/MS-000 *Operational Support and Maintenance Manual for Tent, Main*(p. 2-8), by DND Canada, 1983, Ottawa ON: Department of National Defence. Copyright 1983 by DND Canada.

2. Tighten bracing cables or bracing straps to maximum tension.
3. Attach the foot strap, cinching to the maximum.
4. When using bracing cables, connect the vertical hold anchors with the corresponding D rings at the anchor points along the ground line of the canvas.

5. Drive the pegs into the ground under the sod cloth so that the side wall canvas is taut.
6. Connect the sod cloth flaps with the toggles and loops at the corners and along the sides. Place sod, snow or other suitable material on the sod cloths to prevent the wind from getting underneath them.



A trench is sometimes required when the tent is pitched on poor draining ground such as a flat, clay or heavy soil surfaces or shallow soil over bed rock. Sandy soils or areas which slope off normally do not require drainage trenches. The trench should be 20 cm wide by 15 cm deep. Slope the trench so that it drains away from the tent. Dig outlet drains at the lowest points of the trench, ensuring that they do not interfere with pedestrian or vehicular movement.



Only dig a trench if the situation requires.

### TEARING DOWN

The reverse order for erecting is used to tear down a modular tent. The steps are:

1. Loosen the cables and ground anchors and remove (if wind is not too strong), otherwise leave until the tent is lowered.
2. Remove material from the sod cloth.
3. Release all straps and lacing up to the eave purlins.
4. Lower the tent one side at a time.
5. Unlace tent walls and sections and remove from frame.
6. Dismantle frame (reverse procedure).

Ensure that arrangements are made to clean and dry the equipment, if required, at the earliest opportunity.

### PACKING



A diagram of the packing procedures is located at Attachment A.

To pack a modular tent, use the following steps:

1. Lay out the canvas with the outer surface facing the ground, for ease of cleaning.
2. Fold the front and rear walls by:
  - a. bringing the peak and sides of the wall toward the centre to square off the wall;
  - b. bringing the ends of the walls to the centre of the wall;

- c. folding the wall in half; and
  - d. folding the opposite way to complete the process; and
3. Fold the centre section by:
- a. taking the ends of the section and placing them in the centre of the section;
  - b. taking one end and folding it across to the other end;
  - c. taking the section and folding it into thirds;
  - d. folding the section in half; and
  - e. folding the section in half in the opposite direction.

---

### CONFIRMATION OF TEACHING POINT 2

The cadets' participation in erecting, tearing down, and packing a modular tent will serve as the confirmation of this TP.

---

### Teaching Point 3

**Explain, demonstrate and have the cadets, as a member of a group, erect, tear down and pack an arctic tent or civilian-pattern tent.**

Time: 30 min

Method: Demonstration and Performance



These descriptions and instructions will be given as the tent is being erected, torn down and packed.

If the tent is going to remain erected for the duration of the exercise, instruct tearing down and packing at the end of the exercise.

### COMPONENTS OF A 5- OR 10-PERSON ARCTIC TENT

The 5- and 10-person arctic tents are bell-shaped with a pentagonal base. Each wall section of the pentagon has a snow flap attached to the bottom portion of its panel. The tent consists of an inner and an outer portion. The inner portion is most commonly used for cadet training and consists of a zipper door, base tie-down points, air vents, stove pipe openings and a reinforced apex for pole insertion. The tent is supported by a single telescopic centre pole and 16 (10-person) or 10 (5-person) guy wires. The guy wires are pegged down with lightweight alloy or plastic pegs.

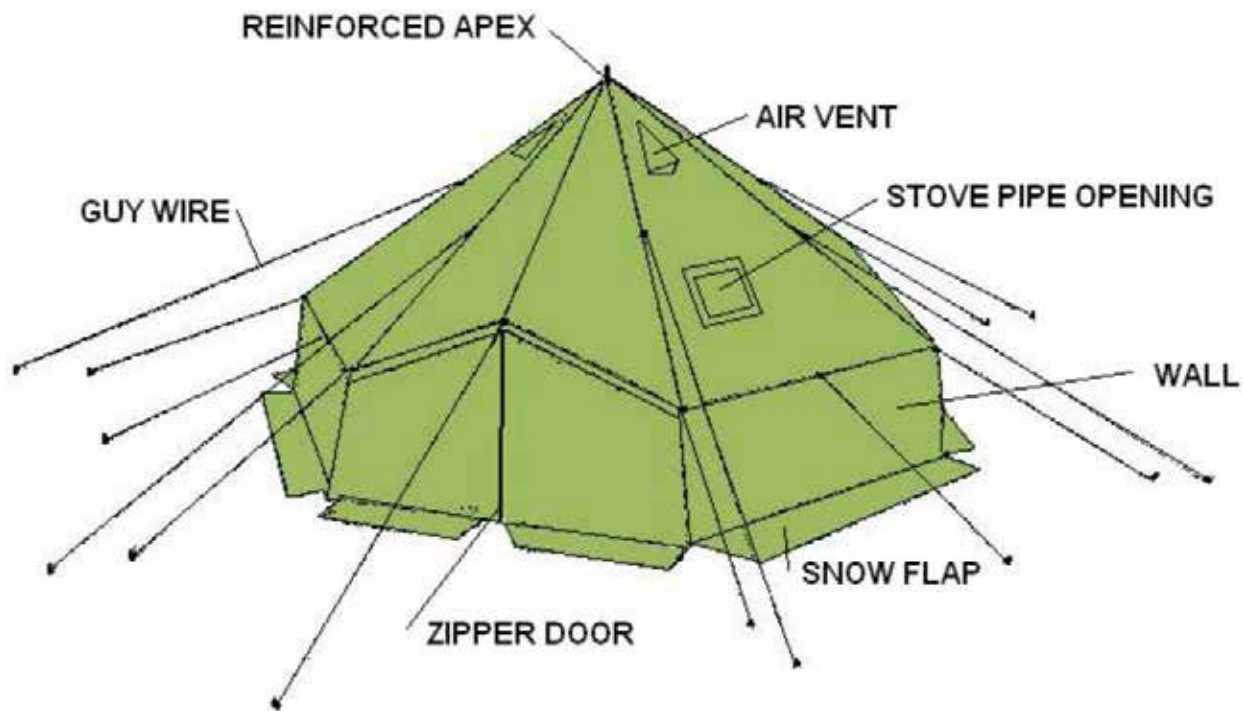

Figure 13 10-Person Arctic Tent Parts

Note. Created by Director Cadets 3, 2007, Ottawa, ON: Department of National Defence.



Figure 14 5-Person Arctic Tent

Note. From *Hero Army Surplus, Army Tents*, by heroarmysurplus.com, 2007. Copyright 2007 by heroarmysurplus.com. Retrieved December 2, 2007, from <http://heroarmysurplus.com/index.php/cPath/116?osCsid=jncvpsk59lech7i4chja975q6>

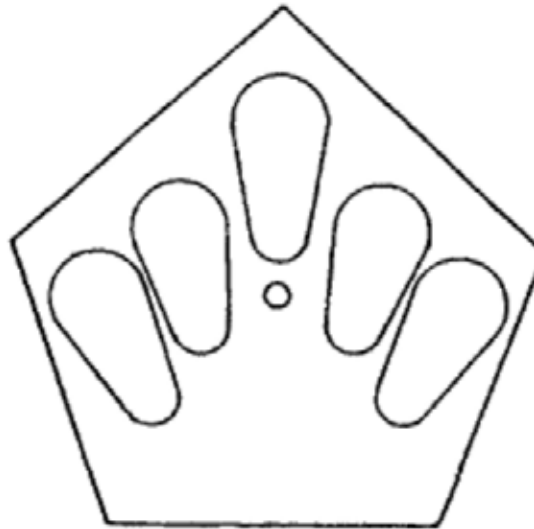

Figure 15 5-Person Arctic Tent Sleeping Arrangement

*Note.* From *B-GG-302-002/FP-001 Arctic and Sub-Arctic Operations, Part 1*(p. 3-11), by DND Canada, 1974, Ottawa ON: Department of National Defence. Copyright 1974 by DND Canada.



Figure 16 10-Person Arctic Tent

*Note.* From *Hero Army Surplus, Army Tents*, by heroarmysurplus.com, 2007. Copyright 2007 by heroarmysurplus.com. Retrieved December 2, 2007, from <http://heroarmysurplus.com/index.php/cPath/116?osCsid=jncvpsk59lech7i4chja975q6>



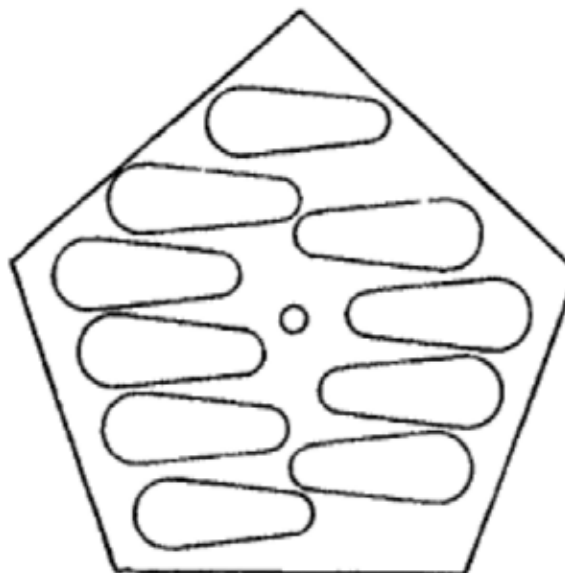

Figure 17 10-Person Arctic Tent Sleeping Arrangement

*Note.* From B-GG-302-002/FP-001 *Arctic and Sub-Arctic Operations, Part 1* (p. 3-12), by DND Canada, 1974, Ottawa ON: Department of National Defence. Copyright 1974 by DND Canada.

### ARCTIC TENT INSPECTION

The tent must be inspected to ensure the following faults are not present:

- reinforced ring on apex damaged or torn;
- air vents are stuck closed or damaged;
- panels have tears, holes, broken threads or seams;
- guy wires or loops are either damaged or missing;
- broken or frayed guy wires or guy wire loops;
- stove pipe opening is damaged or missing;
- zipper on the outer door is broken;
- snow flaps with eyelets are torn away from the walls;
- drying line keepers are torn away from the seams;
- toggles are missing;
- telescopic pole (10-person tent) sections have bends or splits or the pole keeper pin is missing;
- tent pole (5-person tent) has bends or splits and do not fit together properly;
- base plate has cracks and, in the case of the 5-person tent, the base plate keep pin is missing; and
- pegs have broken points or bends.

## ERECTING



Explain and demonstrate the following. Cadets may assist as necessary.

The only difference in erecting these two tents is the number of guy wires. On a 5-person arctic tent there are five wires and on a 10-person arctic tent there are 16. The following outlines the steps to take for erecting a 5- or 10-person arctic tent:

1. Choose a site for the tent (see TP 1 Site Selection).
2. Spread the tent out on the ground with the outside facing up.
3. Ensure the zipper is closed on the front door.
4. Check if the liner is in place; usually it is not in place in a new tent.
5. If the liner is not in place, follow these steps:
  - a. Spread out the liner above the tent with the inside of the tent facing up.
  - b. Attach the top and bottom stove pipe toggles of the liner to the tent.
  - c. Attach the remaining toggles of the liner to the tent. Use the corners of the tent as check points to make sure a toggle was not missed.
  - d. Thread the lower drying line through the drying line keepers.
6. Peg the corners of the arctic tent.
7. The tent pole will be folded in two. Straighten and lock it into position.
8. The individual (pole person) takes the pole and base plate under the canvas, going through the door and inserting it into the centre eye (reinforced apex) of the tent.
9. Secure the base of the pole onto the base plate and have the pole person hold the pole upright.
10. Before erecting the pole, drive the corner pegs into the ground.
11. Have the pole person extend the pole until the skirt and snow flaps are level with the ground. Use the pegs as a guide; they should be pulled out during this step.
12. The pole will have a shackle that needs to be lifted prior to extending. Be careful of the shackle pinching the pole person's fingers.
13. Lock the shackle into place to secure the height of the tent.
14. Pull on each of the lower guy wires and extend them in line with the seams of the tent.
15. Each guy wire will have an adjuster on it; make sure this adjuster is set to the middle position.
16. Peg the guy wires to the ground using heavy duty pegs.
17. Adjust the guy wires to remove any sag in the lower portion of the tent. The tent should be even in height all the way around.

18. Repeat Steps 14–16 with the upper guy wires. The tent guy wires should never cross with other tents.
19. Adjust and tighten all wires and prop up the door wire if necessary.
20. The two door eave wires can be propped up by placing the wire over an improvised pole, tree branch or other object higher than the door entrance. This keeps the doors from sagging and makes it easier to get in and out of the tent and gives the tent greater stability.

### **TEARING DOWN**

Use the following steps to tear down an arctic tent:

1. Have the pole person enter the tent and hold the pole.
2. Pull out the pegs one at a time and roll up the guy wires and tie them off.
3. Have the pole person lower and remove the pole.

### **PACKING**

Use the following steps to pack an arctic tent:

1. Lay out the tent with the tent door up and in the centre with zippers closed and remove any debris.
2. Make sure there are no double folds on the underside.
3. Hold the apex securely. The first long fold is made by folding the wings to the centre, with the pegs straight up and down.
4. Straighten and flatten out the arctic tent.
5. Fold in snow flaps across the base.
6. Make the second long fold, repeating the action for the first long fold.
7. Straighten and flatten out the arctic tent.
8. Make the third long fold, repeating the action for the first long fold.
9. Straighten and flatten out the arctic tent.
10. Make the fourth long fold by flipping the folds one on top of the other.
11. Make the first cross-fold; fold in the base to the top of the wall.
12. Make the second cross-fold by folding the apex into the base of the inserted pole section, allowing approximately 10 cm of loose fold at the base of the pole section to avoid wear and tear. The top of the pole should be offset.
13. Make the third cross-fold by placing the previous two folds one on top of the other.
14. Insert the tent, base plate and pegs into the bag.
15. Place the remaining two pole sections in the bag beside the tent.
16. Tie up the top of the tent bag.

### **SELECTING A CIVILIAN-PATTERN DOME TENT**

To select a suitable civilian tent, consider the number of people it will need to accommodate, seasons during which it is being used, weather conditions that may be encountered, the weight of the tent and required features.

## Seasons and Conditions

**Three-season tents.** Designed to offer good ventilation in the spring, summer, and fall, and provide sturdy weather protection in everything but heavy snowfalls and very high winds. Many three-season tents have mesh inner bodies, which reduce condensation, and can often be used without the fly for a cool, bug-proof shelter on hot nights. Three-season tents are airier, less expensive, lighter, more compact and roomier than four-season tents. Their versatility makes them popular with backpackers, paddlers, and cyclists.



Figure 18 Three-Season Tent

*Note.* From MEC Funhouse 4 Tent, by MEC.ca, 2007, Copyright 2007 by MEC.ca. Retrieved December 2, 2007, from [http://www.mec.ca/Products/product\\_listing.jsp?FOLDER%3C%3Efolder\\_id=2534374302702837&bmUID=1196614958520](http://www.mec.ca/Products/product_listing.jsp?FOLDER%3C%3Efolder_id=2534374302702837&bmUID=1196614958520)

**Four-season tents.** Built to protect in extreme weather. They usually come with many poles and have low, curved shapes to shield high winds and reduce snow buildup. Extra guy wires provide more staking options. Fabrics tend to be heavier, with thicker waterproof coatings that make them more weatherproof, but less ventilated, and more susceptible to interior condensation. This additional protection means greater weight and packed size, and may be inappropriate for anything other than ski touring, winter camping, or mountaineering.



Figure 19 Four-Season Tent

*Note.* From MEC Mondarack Tent, by MEC.ca, 2007, Copyright 2007 by MEC.ca. Retrieved December 2, 2007, from [http://www.mec.ca/Products/product\\_listing.jsp?FOLDER%3C%3Efolder\\_id=2534374302702837&bmUID=1196614958520](http://www.mec.ca/Products/product_listing.jsp?FOLDER%3C%3Efolder_id=2534374302702837&bmUID=1196614958520)

## Weight

Tent weights are described as “minimum weight” and “packaged weight”. The minimum weight includes the tent and frame, and the fewest pegs and guy wires necessary to properly set up the tent. Packaged weight includes the full tent, instructions, stuff sacks, repair swatches, all guy wires and pegs. Conditions permitting, weight can be saved by leaving some pegs and components at home, and improvising with materials available at the site.

## Features

**Tent footprints.** These are groundsheets that are custom-fit to the tent. Groundsheets protect tent floors from abrasions, increase waterproofness, and help insulate from the cool ground. Most tents have pre-made footprints, which are sold separately.

**Vestibules.** This is an excellent way to increase the liveability of a tent. They are useful for storing gear, to peel off wet clothing or put on boots. A pole-supported vestibule will be heavier, but generally larger and more storm-proof.

## ERECTING

### Setting up the Main Body

Use the following steps to set up the main body of a civilian-pattern dome tent:

1. Remove sharp objects that might puncture the tent floor. A footprint beneath the structure is not necessary for a waterproof tent, but it will reduce long-term wear on the tent floor.
2. Assemble all poles carefully.



Shock-corded poles (bungee cord) are meant to keep pole sections in the proper order, not as an automatic assembly mechanism for poles. Do not hold one section while whipping the rest of the pole back and forth, or toss the poles into the air; either procedure excessively stresses the pole joints and shock cord. Instead, fit poles together section by section, making sure that each piece slides completely into the next. Forcing an improperly assembled pole can damage the pole and / or the tent body and fly.

3. Lay the tent body flat. In windy conditions, peg all the floor corners before proceeding.
4. Lay the poles on top of the tent body so that each one crosses diagonally from one corner to the opposite corner; the two poles should cross in the centre to form an X.
5. Attach the pole clips to the canopy.
6. Fit the pole ends into the grommet tabs at the four corners of the tent.



Have one person lift the top of the tent to loft it up as the tension can cause the other poles to pop out. This is the stage when the greatest stress can be placed on the poles. There is often more than one grommet on each webbing tab to increase or decrease the tautness of the tent to compensate for fabric slackening or tightening caused by changes in humidity. When first erecting the tent, it is best to use the outermost (loosest) grommet on each tab.

7. Starting at a point over one of the doors, attach the clips on the tent to the poles.
8. Peg out the corners of the tent.



Most tents are colour-coded to help users put them up easier.

### **Attaching the Fly**

1. Drape the fly over the tent so that the doors in the fly line up with the doors in the canopy.
2. Attach the Velcro wrap-ties to secure the fly onto the poles. They are usually on the underside of the fly on most tents. Attaching these wrap-ties is very important for strengthening the tent. The wrap-ties allow the poles to reinforce one another in a series of trusses; they also connect the corner guy wire attachment points directly to the poles for maximum stiffness when these guy wires are rigged.
3. Fit all of the grommet tabs on the fly over the appropriate pole ends.

### **Staking and Guying Out the Tent**

Attach, peg out, and tension the four corner guy wires. Rather than thick, heavy poles for strength, most tents employ light, sturdy guy wires as part of their structure. This keeps the tents weight low. The design also makes it very important to securely rig the guy wires in any amount of wind. Not doing so could cause the tent to move in the wind (as with any tent, shelter from trees, rock, or snow walls will make for a quieter night under stormy conditions).



The pegs included with a tent are suitable for general use on relatively soft ground. On very hard-packed ground, use stakes that can withstand the force needed to secure them. On snow, sand, or other loose-packed surfaces, wider T-stakes or aluminum snow stakes will hold better; these stakes hold best buried horizontally. Improvise with other stakes (hiking staffs, ice axes, branches, rocks, trees), using the tents stake loops or cord as required.

### **Ventilating the Tent**

Proper ventilation is the key to minimizing condensation in any tent. Some points to consider are:

- Keep fabric doors open as widely as the prevailing weather permits.
- If bugs are not a problem, leave mesh doors open.
- Open each door from the top down; warm, moist air rises and will escape through high openings.
- If the design of the tent allows, open it at either end or both sides to allow air to flow through.
- On very hot nights, when there will be no rain or dewfall, leave the flysheet off and use the inner tent to keep out bugs.

### **TEARING DOWN AND PACKING**

The most important consideration in taking down a tent is not to stress the poles and fabrics by following these steps:

1. Disconnect guy wires and release the tension from the tent.
2. Release all the poles. If the tent has pole sleeves, push the poles out of the sleeves instead of pulling them out.
3. To minimize the stress on the bungee cord in the poles and to speed disassembly, fold each pole in half first, and then fold down towards the outsides, two sections at a time.
4. Make sure to remove all of the components from one another prior to storing. A wet tent should be dried prior to packing as the moisture will damage the tent over time.
5. If possible, fold and roll the tent rather than stuffing it into its sack. Rolling makes a smaller package, and causes fewer creases in the polyurethane coating. The tent and poles may be carried separately for easier packing or load sharing.

### **MAINTAINING THE TENT**

#### **Protecting the Tent**

Ultraviolet (UV) damage is the largest hazard for tents. Fabrics should not be exposed to sunlight for extended periods of time; this will eventually result in colour fading and fabric failure. The uncoated fabrics of the tent canopy are most susceptible to damage from UV and should be covered by the more durable fly. If extended exposure is unavoidable, cover the tent with a tarp or a sheet of nylon.

#### **Lighting the Tent**

Using a candle lantern in a tent carries definite risks. Never leave a candle lantern burning unattended; always watch for fire hazards from overheating fabrics or spilling wax. Spilling wax can be dangerous, particularly to eyes and other sensitive areas. Use candle lanterns wisely and with extreme caution. Cooking in a tent is strongly discouraged because of fire hazards and carbon monoxide inhalation risks. Unlike campfire smoke and other fumes, carbon monoxide can render someone unconscious without warning.

### **Not Eating in the Tent**

Mop up spills promptly with water. Many foods, particularly acidic ones like fruit or juices, can weaken synthetic fabrics over time. It is best to eat and store food away from a tent to avoid attracting animals.

### **Cleaning the Tent**

Clean the tent by hand while it is set up, using a sponge, a mild non-detergent soap, and warm water. Rinse thoroughly. Do not dry clean, machine wash, or machine dry. Stubborn stains like tar can be left in place and dusted with talcum powder to prevent transfer to other areas of the tent in storage. After cleaning, a spray-on water repellent designed for synthetic fabrics may be applied to the flysheet if surface water repellent is weakened. This is apparent when water droplets no longer bead on the fabric. If the poles are exposed to salt or salt water, rinse them in fresh water and allow them to dry before storing (while aluminum does not rust, it can become brittle through unseen corrosion over time).

---

### **CONFIRMATION OF TEACHING POINT 3**

The cadets' participation in erecting, tearing down and packing an arctic tent or civilian-pattern tent will serve as the confirmation of this TP.

---

### **END OF LESSON CONFIRMATION**

The cadets participation in erecting, tearing down and packing a modular tent and either an arctic tent or civilian-pattern tent will serve as the confirmation of this lesson.

---

### **CONCLUSION**

---

### **HOMEWORK / READING / PRACTICE**

Nil.

### **METHOD OF EVALUATION**

Nil.

### **CLOSING STATEMENT**

It is important for the cadets to be able to setup / tear down a modular tent because they are often used during aircrew survival exercises. A cadet's understanding of this lesson will allow them to better assist in the set-up of a aircrew survival exercise.

### **INSTRUCTOR NOTES / REMARKS**

If the squadron does not have access to modular tents, have the cadets erect, tear down and pack the arctic tent and the civilian-pattern tent.

Cadets who are qualified Survival Instructor may assist with this instruction.

---

### **REFERENCES**

---

A3-059 C-87-110-000/MS-000 Canadian Forces. (1983). *Operational support and maintenance manual: Tent, main*. Ottawa, ON: Department of National Defence.



A3-060 B-GG-302-002/FP-001 Canadian Forces. (1974). *Arctic and Sub-Arctic operations: Part 1*. Ottawa, ON: Department of National Defence.

THIS PAGE INTENTIONALLY LEFT BLANK

**FOLDING A SINGLE TENT SECTION**

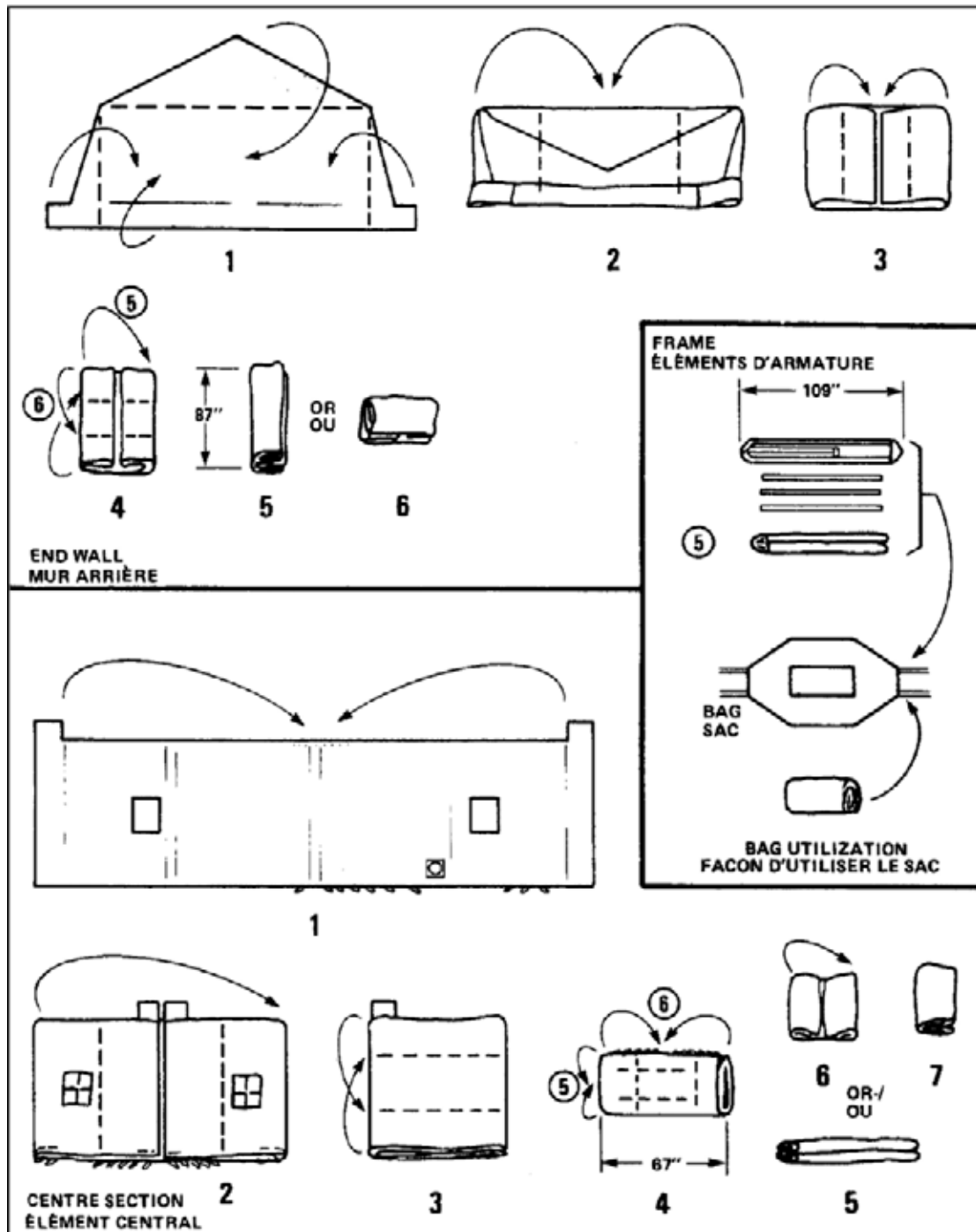

Figure A-1 Folding a Single Tent Section

Note. From C-87-110-000/MS-000 Operational Support and Maintenance Manual for Tent, Main(p. 2-17), by DND Canada, 1983, Ottawa ON: Department of National Defence. Copyright 1983 by DND Canada.

### FOLDING LACED TENT SECTION

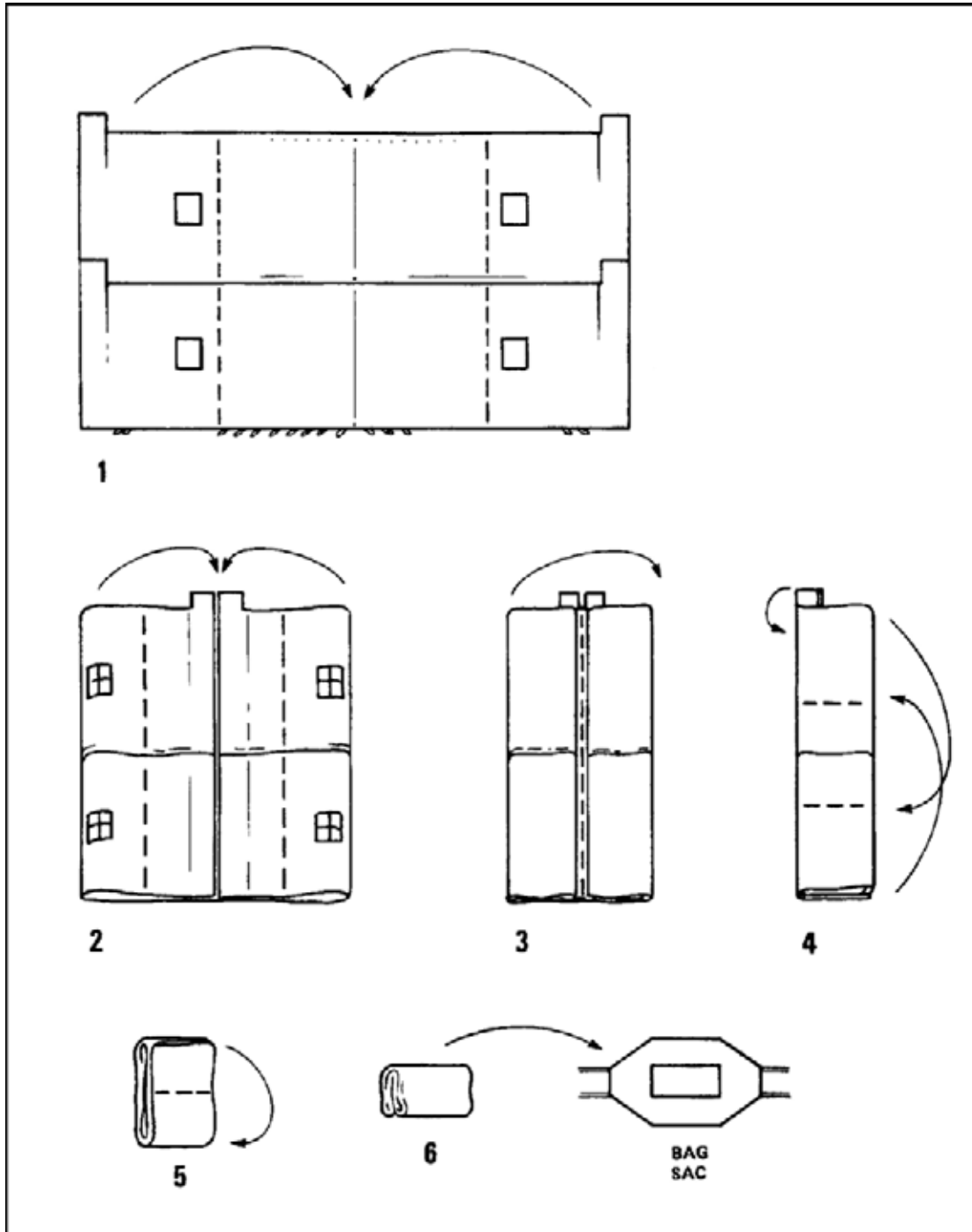

Figure A-2 Folding Laced Tent Sections

Note. From C-87-110-000/MS-000 *Operational Support and Maintenance Manual for Tent, Main*(p. 2-18), by DND Canada, 1983, Ottawa ON: Department of National Defence. Copyright 1983 by DND Canada.